

INSTRUCTION MANUAL
LP QUATRO PUMP
& FLUID SECTION, model 4 BALLS STAINLESS
STEEL
- 3700 cc / 125 oz

	Version	Pump #	Fluid section #
	5/1 - 3700 cc	47 225 340 xx xx	105 340 xx xx
	8/1 - 3700 cc	49 225 340 xx xx	105 340 xx xx

Manual : 574.212.112 - 2107
 'PMP15'

Date : 21/07//2021 Supersede : 06/10/10

Modif. : Update

ORIGINAL MANUAL

IMPORTANT : Read and understand all instructions before storing, installing and operating concerned equipment (professional use only).

PICTURES AND DRAWINGS ARE NOT CONTRACTUAL. THE MATERIAL MAY BE CHANGED WITHOUT PRIOR NOTICE.

SAMES KREMLIN SAS
 13, chemin de Malacher
 38 240 - MEYLAN - France
 ☎ : 33 (0)4 76 41 60 60

www.sames-kremlin.com



INSTRUCTION MANUAL
LP QUATRO PUMP
&
FLUID SECTIONS, model 4 BALLS ST STEEL - 3700cc / 125 oz

CONTENTS

1. DECLARATION OF CONFORMITY.....2

2. WARRANTY2

3. SAFETY INSTRUCTIONS.....3

4. INSTALLATION.....6

5. OPERATING.....7

6. USE.....7

7. MAINTENANCE.....10

8. CODIFICATION OF THE PUMPS11

9. SPECIFICATIONS11

10. DISASSEMBLY / ASSEMBLY12

11. EXPLODED VIEW & SPARE PARTS' LIST14

ADDITIONAL DOCUMENTATIONS :

<u>Spare parts :</u>	Description	Manual #
	Motor, model 7200 / 9200	Doc. 574.226.112

Dear Customer,

You are the owner of our new equipment and we would like to take this opportunity to thank you.

To make sure your investment will provide full satisfaction, special care has been taken by SAMES KREMLIN during all designing and manufacturing processes.

To obtain the best result, safe and efficient operation of your equipment, we advice you to read and make yourself familiar with this instruction and service manual. Indeed, the non-compliance with instructions and precautions stated in this manual could reduce the equipment working life, result in operating trouble and create unsafe conditions.

1. DECLARATION OF CONFORMITY

The manufacturer : **SAMES KREMLIN** with assets of 6 720 000 Euros

Head office : 13, chemin de Malacher 38 240 - MEYLAN - France

Tel. 33 (0)1 49 40 25 25 - Fax : 33 (0)1 48 26 07 16

Herewith declares that :

Description	FLUID SECTIONS, model 4 BALLS	PUMP	
Equipment part number	105 340 xxxx	47 225 340 xxxx	49 225 340 xxxx
Trademark	SAMES KREMLIN		

Could not be used before the equipment in which it will be incorporated is declared in conformity with the :

- ATEX Directive (Directive 94/9/EEC):  II 2 G (group II, class 2, gas).

Established in Stains, on October 5th 2005



Dominique LAGOUGE

Vice President

2. WARRANTY

We reserve the right to make changes; these changes may be carried out after the receipt of our order. No claim will be accepted as a consequence of any change carried out in the instruction manuals or in the selection guides.

Our equipment is checked and tested prior to shipment. In the case of a problem arising with the equipment, this must be in writing, within ten days from the delivery date.

SAMES KREMLIN warrants all equipment manufactured bearing its name, to be free from defect in material or workmanship for a period of 12 months (one shift per day or 1800 hours - 1 term reached) from the date of delivery. Work life is based on single shift working - 8 hours per day. Warranty claims for defective items will only be accepted in writing and will be verified and confirmed by us.

The warranty does not cover fair wear tear, damage or wear caused by misuse, improper maintenance or non-observance of our recommendations.

SAMES KREMLIN will repair or replace parts (carriage paid to our plant and accepted as defective by us). We shall not be liable for any losses, resulting from a production breakdown. Upon request, we can carry out service work at your premises; all expenses (travelling and accommodation) for SAMES KREMLIN technicians will be chargeable.

In the event that it is found that equipment has been tampered with, this will invalidate the warranty. Equipment that is bought in will be subject to the supplier's warranty.

3. SAFETY INSTRUCTIONS

GENERAL SAFETY INSTRUCTIONS



CAUTION : The equipment can be dangerous if you do not use it according to the rules mentioned in this instruction manual. Read carefully all the instructions hereafter before operating your equipment.

Only trained operators can use the equipment. (To acquire an essential training, please contact the "SAMES KREMLIN University" training center - Stains).

The foreman must ensure that the operator has perfectly taken in the safety instructions of this equipment as well as the instructions in the manuals of the different parts and accessories.



Read carefully all instruction manuals, label markings before operating the equipment.

Incorrect use may result in injury. This equipment is for professional use only. It must be used only for what it has been designed for. Never modify the equipment. The parts and accessories supplied must be regularly inspected. Defective or worn parts must be replaced.

Never exceed the equipment components' maximum working pressure.

Comply with regulations concerning safety, fire risks, electricity in force in the country of final destination of the material. Use only products or solvent compatible with the parts in contact with the material (refer to data sheet of the material manufacturer).

PICTOGRAMS

					
NIP HAZARD	WARNING MOVING ELEVATOR	WARNING MOVING PARTS	WARNING MOVING SHOVEL	DO NOT EXCEED THIS PRESSURE	HIGH PRESSURE HAZARD
					
RELIEF OR DRAIN VALVE	WARNING HOSE UNDER PRESSURE	WEAR GLASSES OBLIGATORY	WEAR OF GLOVE IS OBLIGATORY	PRODUCT VAPOR HAZARDS	WARNING HOT PARTS OR AREAS
					
ELECTRICAL HAZARD	WARNING FIRE HAZARDS	EXPLOSION HAZARDS	GROUNDING	WARNING (USER)	WARNING SERIOUS INJURIES

PRESSURE HAZARDS



Current legislation requires that an **air relief** shut off valve is mounted on the supply circuit of the pump motor to let air off when closing the supply circuit. Without this precaution, the motor residual air of the motor may let the pump beat and cause a serious injury.

Please ensure that, a **material drain valve** is mounted on the material circuit to drain it (after shutting down air to the motor and the pressure relief) before any servicing on the equipment. These valves must be closed for air and opened for product when processing.

HIGH PRESSURE INJECTION HAZARDS

When working with high pressure equipment, special care is required. Fluid leaks can occur. Then there are injection risks in exposed parts of body that may cause severe injuries or amputations :



- Medical care must be handled immediately if product is injected under the skin or in other parts of the body (eyes, fingers).

- Never point the spray gun at any one. Never try to stop the spray with your hands or fingers nor with rags or similars.



- **Follow the shut down procedure and always depressurize air and fluid circuits** before carrying out any servicing on the gun (cleaning, checking, maintenance of the material or cleaning of the gun nozzles).

- For the guns equipped with a safety device, always lock the trigger when you do not start the gun.

FIRE - EXPLOSION - SPARKS - STATIC ELECTRICITY HAZARDS

A poor earth connection, inadequate ventilation, sparks or static electricity can cause an explosion or fire. to avoid these risks when using or servicing SAMES KREMLIN equipment, the following safety procedures must be followed :



- ensure a good earth connection and ground the parts to be handled i.e. solvents, materials, components and equipment,

- ensure adequate ventilation,

- keep working area clean and free from waste solvents, chemicals, or solid waste i.e. rags, paper and empty chemicals drums,



- never use electrical switches / power if in an atmosphere of volatile solvent vapour,

- stop working immediately in case of electrical arcs,



- never store chemicals and solvents in the working area,

- use paint whose flash point is the highest possible to prevent from any formation of gas and inflammable vapours (refer to materials' safety instructions),

- install a cover on the drums to reduce the diffusion of gas and vapours in the spray booth.

TOXIC PRODUCT HAZARDS

Toxic products or vapours can cause severe injury not only through contact with the body, but also if the products are ingested or inhaled. It is imperative :



- to know the material products and their risks,

- notified or hazardous materials must be stored in accordance with the regulations,

- the material must be stored in an appropriate container, never place materials in a container where there is a risk o spillage or leakage,

- a procedure must be applied for the safe disposal of waste material. It must comply with all prevailing regulations and legislations of the country where the equipment is to be used,

- protective clothing should always be worn in compliance with the material manufacturers' recommendations,

- depending on the application and chemical safety instructions, safety glasses, gloves, foot wear, protective masks and possible breathing equipment should be worn to comply with the regulations

(Refer to chapter "Safety equipment of KREMLIN selection guide).



CAUTION!



It is forbidden using any solvent or with halogenated hydrocarbon base and also products with these solvents facing **aluminium** or **zinc**. The non-compliance with the instructions may cause explosion hazards causing serious or fatal injuries.

EQUIPMENT REQUIREMENTS

PUMP

Before carrying out any work, it is imperative to get used with the compatibilities of motors with pumps before coupling. The operator shall understand the equipment and the safety instructions. These instructions are available in the manuals of the pumps.



The air motor is designed to be mounted with a pump. Never modify any components or couplings. Where operating, please keep hands away from moving parts. Before starting up the equipment, please read the PRESSURE RELIEF instructions. Please ensure that any relief or drain valves fitted are in good working order.



HOSES

- Keep hoses out of circulation areas, moving parts or hot surfaces,
- Never expose product hoses to temperature higher than + 60°C / 140° F or lower than 0°C / 32° F,
- Never pull or use the hoses to move the equipment,
- Tighten all fittings as well as the hoses before operating the equipment,
- Check the hoses regularly; change them if they are damaged,
- Never exceed the working pressure (WP) indicated on the hose.

USED PRODUCTS

Considering the variety of products that may be used by the users and the impossibility to check off all chemical data, of possible reactions of chemicals to each other and their long term evolution, SAMES KREMLIN can not be considered as liable for :

- the bad compatibility of wetted parts,
- risks for staff and surroundings,
- for worn or out of order parts, for wrong working of equipments or units, as well as for the qualities of final product.

The user must know and prevent the possible risks as toxic vapours, fires or explosions due to used products. He shall determine the risks of immediate reactions or pursuant to repeated exposures of the staff.

SAMES KREMLIN shall not be liable for psychic injuries, direct or indirect material damages further to the use of chemicals.

4. INSTALLATION

■ HANDLING



The pumps and the fluid sections with important weight and dimensions must be handled with the appropriate means.

■ STORAGE

Place the equipment safe from dampness after having closed the different air inlets and ports (plugs).

■ DESCRIPTION OF THE LABEL MARKING

Marking in accordance with the ATEX directive

REF / SERIE	MOTEUR / MOTOR	POMPE / PUMP	MOTO-POMPE / MOTOR-PUMP
○ Max.pres.(bar/psi)			○
	KREMLIN REXSON France		
			RATIO

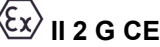
SAMES KREMLIN FRANCE	Name and address of the manufacturer
MOTEUR / MOTOR	Motor part number and serial number
POMPE / PUMP	Part number of the fluid section and serial number
MOTO-POMPE / MOTOR-PUMP	Part number of the pump and serial number
	<p>II : group II 2 : class 2 Surface equipment meant to area where explosive atmospheres due to gas, vapours, mists or air mixtures with dusts are liable to appear from time to time in usual operating. G : gas</p>



Associated to a pneumatic motor, the fluid sections must be grounded via the earth cable of that motor.

The earth cable must be grounded to a safe earth.

The pumps are designed to be installed in a spray booth.

■ CONNECTION OF THE SUBSETS

These fluid sections are designed for the coupling of pneumatic or hydraulic motors with similar stroke. These pumps must operate in vertical position.

You must conform to a motor / fluid section association as planned by SAMES KREMLIN.

5. OPERATING

■ EXPECTED USE

These fluid sections coupled with pneumatic or hydraulic motors are designed for the transfer, the pouring off or the spraying of different liquid or viscous fluids with a requested outlet flow and pressure.

■ OPERATING DESCRIPTION

DOUBLE EFFECT pump : suction and exhaust are carried out in the 2 translations stages.

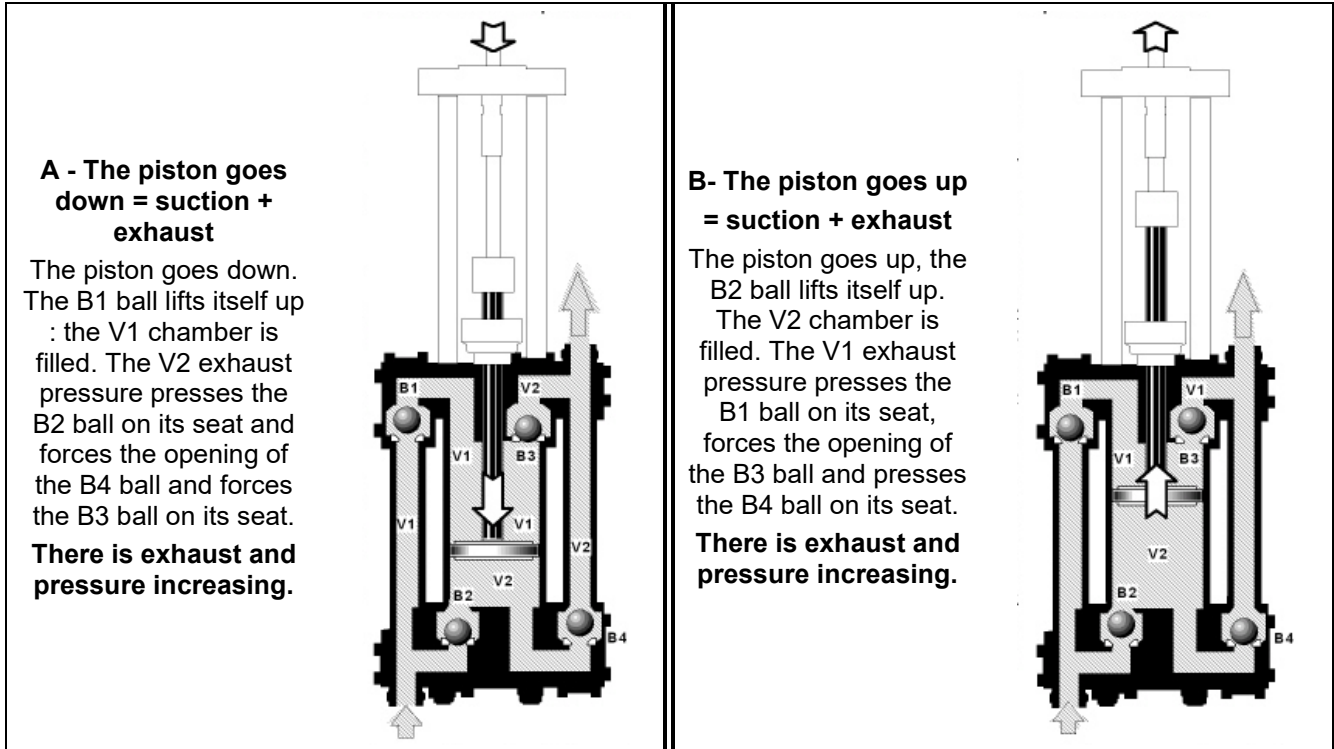

WARNING!

The frictions due to the displacement of fluid inside the pump and its accessories, as well as the one created by the tightness seals, generate static electricity that may cause fire or explosion. This is why the fluid section must be grounded (refer to the instruction manual of the motor for its grounding).

Never place hands on the suction port of the pump. The suction power can lead to serious injuries.

6. USE



Protective clothing (gloves, protective masks, glasses, protective clothing,...) should be worn to comply with the recommendations.

The working area must be correctly ventilated.

■ ADJUSTMENTS

Before starting the equipment, half fill the cup with T lubricant.

The cup nut must be slightly tightened. A too important tightening would damage the cup seals. A wrench is supplied to allow a correct tightening.

Tightening of the wetting cup :

- Fill the cup with T lubricant,
- Start the pump, then tighten the cup after 10 minutes, then one hour and then one day of operating,
- If you notice a leakage, the cup must be tightened.

Tightening instructions :

- Depressurize the motor (refer to pressure relief instructions),
- Depressurize the fluid circuit (refer to pressure relief instructions),
- Tighten the cup, clean it and fill it with T lubricant,
- Close the pump drain circuits,
- Open the motor air valve.

■ START UP

The pumps are tested in our workshop with lubricant.

Before starting up, you must flush the pump with the appropriate solvent.

At the end of the working day, carry out a flushing with the appropriate solvent. We advice you to stop the fluid section in the "low position" to prevent material spreading on the piston rod.

■ TROUBLESHOOTINGS



Before any intervention on the pump, please carry out the release pressure and drain general instructions.

To prevent from injuries, material injections, injuries due to moving parts or sparks during the stopping of the system, the assembly, the cleaning or changing of the nozzle, **you must follow the stages hereafter** before intervening :

- Close the guns,
- Shut off the air inlet using the pressure release to evacuate the residual air.
- Move the gun near to a metallic drum to get back the fluid. Keep it against the drum to maintain the grounding (if necessary use a wire to ground the metallic drum).
- Open the gun to drain the circuit.
- Open the drain valve of the pump and get back the fluid in a metallic drum correctly grounded.
- Let the drain valve open during the intervention.

Check the conformity of cabling before intervening.

DEFECTS	CAUSES	SOLUTIONS
Leakage at the cup seals	Insufficient tightening of the cup. Bad mounting of the seals Damaged or worn seals. Bad choice of the seals' material	Screw the cup. Check the mounting Replace them. Check the compatibility.
The cup seals get rapidly damaged	No lubricant in the cup (pumped product drying on the piston rod). Compatibility product / seals.	Clean, replace parts if necessary. During a long duration shutdown, stop the pump, the piston is in the low position. Check.
The pump is stopped	The fluid is polymerized, hardened, dried in the pump. The cup nut is too tightened. Broken part(s) in the pump.	Clean the pump; change parts if necessary. Unscrew. Remove, check and replace.
The motor seems to operate but the pump does not deliver product	Internal parts of the motor defective. Defective coupling.	Check the operating of the motor. Check coupling.
The pump operates but irregular flow	Valve clogged on the seat, incorrectly mounted or worn. Air inlet in the suction circuit.	Check mounting, state of the parts, tightening of parts and seals.
At stop, pump piston carries on going down	Valve worn or incorrectly mounted Plug or drain valve not tightened	Check and replace parts.
At stop, pump piston carries on going up	Head piston seals or upper valve worn or incorrectly mounted. Plug or drain valve not tightened	Check and replace parts.
The piston is going down quickly (simple effect working)	Bad feeding of the pump. Product is too viscous. Lower valve worn. A foreign product obstructs the lower valve. Lower valve getting up too weak	Check use parameters of the accessories (pressure on follower plate or suction rod,...). Accessories can be not adapted or clogged. Bad definition of the pump. Check and replace parts. Clean and check. Displace the ball cage to increase the getting up.
The piston goes up quickly	Valve worn or damaged. A foreign product obstructs the upper valve.	Check and replace parts. Clean and check.
The piston goes up and down at different speeds	Valve, head piston seals or cylinder worn. Seals incorrectly mounted or damaged	Replace parts. Check the mounting; change if necessary.

DEFECTS	CAUSES	SOLUTIONS
The pump does not deliver enough pressure	Insufficient air pressure to the motor (valve insufficiently open, air leak,...) Insufficient air inlet on the motor or outlet clogged.(hose not adapted) Cup or head piston seals too tightened.	Check; adjust. Check filter, mounting, hose not adapted. Check mounting or loosen cup nut.
Abnormal operating after racing or too important temperature.	Head piston or cup seals too tightened, damaged. Product drum empty.	Check mounting; reduce pumping rhythm. Replace parts if necessary. Fill the drum; check the suction circuit and possible air leakage.
Fluid leakage from the cartridge seals	Cartridge seal incorrectly mounted Seals incorrectly mounted or damaged	Check the assembly Change.
Fluid leakage from the pump body	Cylinder tightened No seals or seals damaged	Check parts and change them if necessary

7. MAINTENANCE



WARNING!

Before any intervention, please follow the pressure release instructions and read carefully the safety instructions.

During a long duration shutdown, stop the pump when the piston is in low position.

■ PREVENTIVE MAINTENANCE

Daily care :

Check if there are leaks. Check that the hoses are in good conditions.

Keep the piston of the pumps clean to prevent from material drying.

Check the PE level inside the shell (keep the level halfway up). Fill it if necessary. The lubricant will normally be coloured by the material.

Tighten moderately if necessary the cup nut with the wrench provided.

Check the tightening of the different parts.

Manipulate (open and close) all the valves of the installation.

Keep the spray area clean.

Bimonthly care :

If the lubricant is excessively coloured in the cup, fill the cup with new lubricant. Leave the cup clean and clean it regularly with lubricant after having drained the lubricant.

Yearly :

Remove the fluid section completely. Clean the parts. Install new seals during the assembly of the pump (refer to package of spare seals).

■ CURATIVE MAINTENANCE

We advice you to schedule a systematic maintenance after a given working time. The rhythm is defined by the maintenance staff of the user and is done according to the product, the rate of work and the regular using pressure.

Before intervening on the equipment :

- Clean the parts with the appropriate cleaning solvent,
- Install new seals if necessary after having lubricated them,
- Lubricate the piston and the inside of the cylinder to prevent from damaging the seals,
- Install new parts if necessary.

8. CODIFICATION OF THE PUMPS

Pump, model QUATRO LP		Motor associated	Fluid section, model 4 balls
Version	#	Version	Version
5/1 - 3700 cc / 125 oz	47 225 340 01xx	7200 (stroke : 200 mm /8")	3700 cc / 125 oz st steel
8/1 -3700 cc / 125 oz	49 225 340 01xx	9200 (stroke : 200 mm / 8")	

Fluid sections	#	Description
3700 cc / 125 oz	105 340 01xx	Standard fluid section (I/O 1"1/4)

xx : depending upon package of seals

9. SPECIFICATIONS**■ FEATURES**

Features of the pumps	Pump # 47 225 340 01 xx	Pump # 49 225 340 01 xx
Pressure ratio	5/1	8/1
Maximum air pressure	6 bar / 87 psi	6 bar / 87 psi
Maximum fluid pressure	30 bar / 436 psi	48 bar / 696 psi
Delivery per cycle	3700 cc / 125 oz	3700 cc / 125 oz
Fluid flow rate	74 l for 20 cycles / mn	74 l for 20 cycles / mn
Noise level	< 80 dBa	< 80 dBa
Weight	129 kg / 284.3 lb	138 kg / 304 lb

Features of the fluid sections	# 105340 01xx
Capacity	1850 cc / 62.5 oz
Delivery per cycle	3700 cc / 125 oz
Stroke	200 mm / 8"
Fluid inlet / outlet	F 1" 1/4
Weight	85 kg / 187.4 lbs
Maximum fluid temperature	80°C / 176° F
Wetted parts	Steel treated stainless steel, VITON, PTFE G, Polyurethane, Polyethylene
Packings	Depending upon package of seals

■ DIMENSIONS

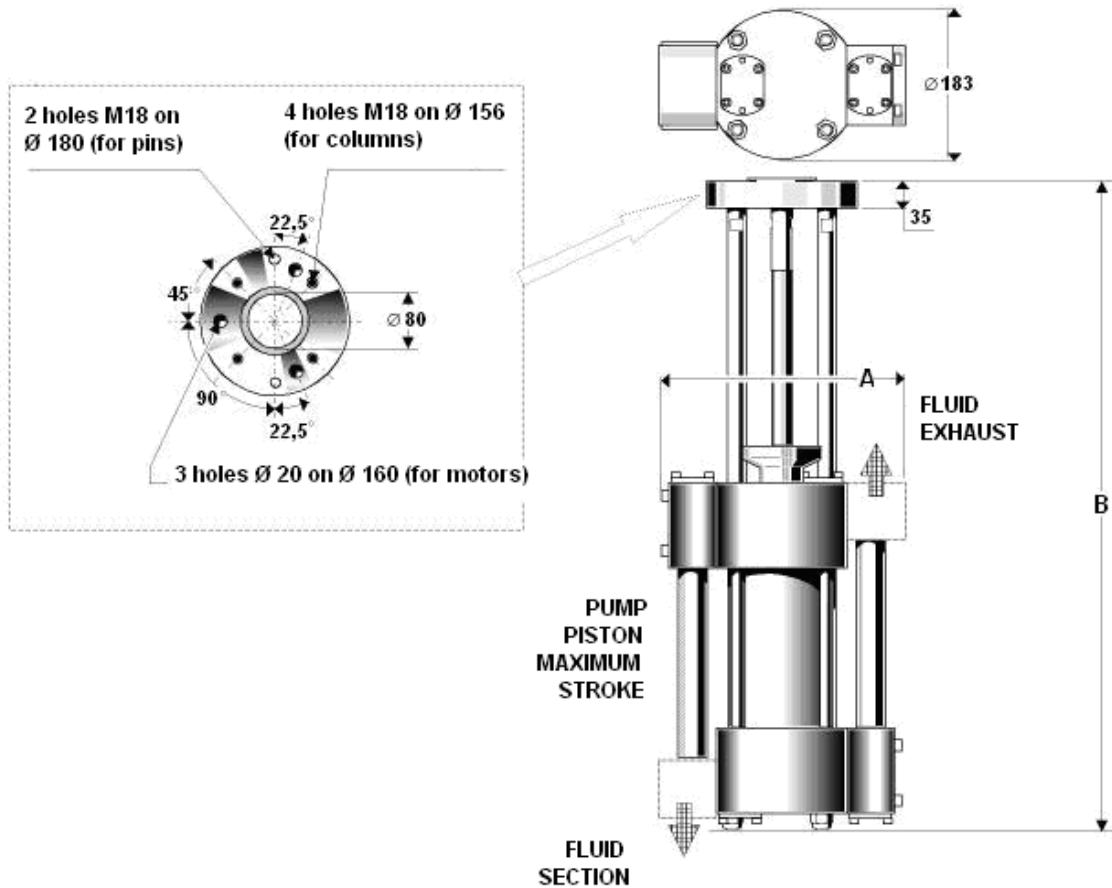

# Fluid section	A (mm / ")	B (mm / ")	Inlet / Outlet Ø
105 340 01XX	282 / 11.1	896 / 35.3	F 1"1/4 G

10. DISASSEMBLY / ASSEMBLY



WARNING!
Before any intervention, please follow the pressure relief and safety instructions

Disassembly of the fluid section

- Stabilize the pump on the floor vertically on the face of the connecting flange (1),
- Unscrew the fixing screws (20) of the inlet/outlet flanges / connecting rod and those of the valve boxes (upper and lower),
- Remove the seals (22),
- Unscrew the 4 nuts (38),
- Remove the lower body (36), put aside the cylinder (25),
- Remove the piston assembly and the upper body (23).

Cartridge

- Unscrew the screw (39),
- Unscrew the terminal (40),
- Remove the cup (6),
- Unscrew the cup nut (9),
- Unscrew the 4 screws (7),
- Remove the cartridge assembly,
- Unscrew the cartridge (14) of the nut (9),
- Remove the spacer (10),
- Remove the O-Rings (8 & 15), the washers (11 & 13), the seals (12).

Reinstall the parts in the reverse order of the disassembly sequence. We advice you to lubricate the screws and the seals.

Upper and lower valves (of the valve boxes [35] and of the bodies [23 & 36])

- Unscrew the 4 screws (7),
- Remove the plug (16),
- Take off the ball housing (17), the ball (18), the seat (19) and the seals (8).

Reinstall the parts in the reverse order of the disassembly sequence.

Piston assembly (from 26 to 34)

- Unscrew the 4 screws (34),
- Remove the support washer (33),
- Remove the seal (31),
- Unscrew the nut (32),
- Unscrew the head (28) of the piston rod (26).

Reinstall the parts in the reverse order of the disassembly sequence.

Assembly of the fluid section

- Locate the upper block (23) on the columns (5),
- Locate the cylinder (25) fitted with the seals (24),
- Install the piston assembly (lubricate the seal with a neutral oil) in the cylinder,
- Locate the lower body (36) on the columns (5),
- Take the 4 nuts (38),
- Install the upper valve (35) and the outlet flange (21) locating the seals (22),
- Take the 8 screws (20),
- Install the two connecting tubes (30) fitted with the seals (27) on the upper valve and the outlet flange,
- Install the lower valve (35) and the inlet flange (21) on the connecting tubes locating the seals (22),
- Take the 8 screws (20),
- Tighten all the screws and the tie-rods,
- Locate the pump vertically (connecting flange upwards),
- Install the cup (6).

Couple the fluid section and the motor.

Before intervening on the equipment :

- **Clean the parts with the appropriate cleaning solvent,**
- **Install new seals if necessary after having lubricated them,**
- **Lubricate the piston and the inside of the cylinder to prevent from damaging the seals,**
- **Install new parts if necessary.**

11. EXPLODED VIEW & SPARE PARTS' LIST

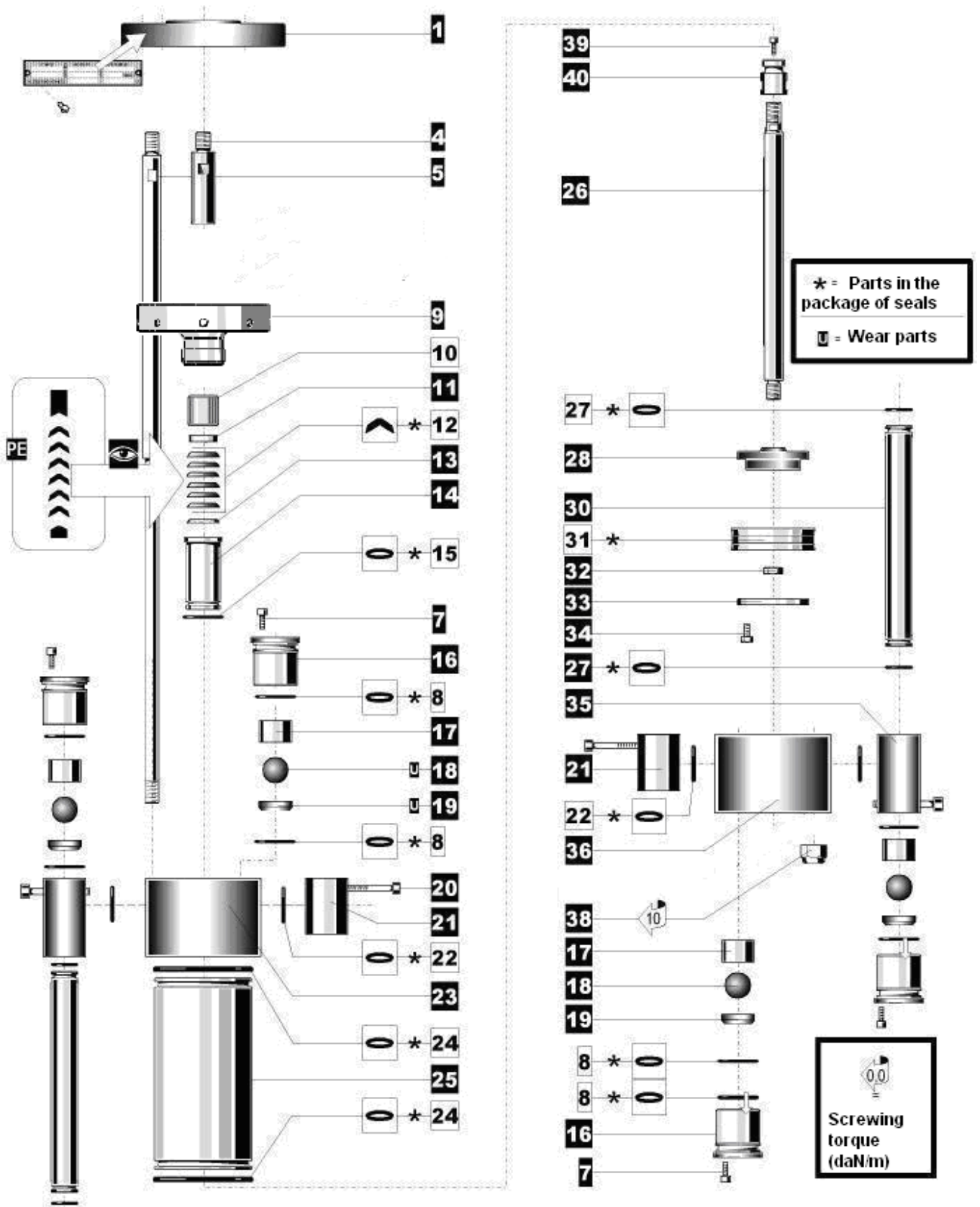

■ SPARE PARTS' LIST

PUMP

		Pump 5/1 - 3700cc / 125 oz # 47 225 340 01xx	Pump 8/1 - 3700cc / 125 oz # 49 225 340 01xx	
Ind.	Description	#	#	Qty
-	Motor	105 272	105 292	1
-	Fluid section, model 3700 cc	105 340 01xx	105 340 01xx	1
-	Screw, model CHC M 18x55	88 960	88 960	3

FLUID SECTION, model 3700cc stainless steel

Ind.	Description	#	Qty
1	Connecting flange	209 869	1
4	Pin	209 582	2
5	Tie-rod	209 864	4
7	Screw, model st steel CHc M 6x16	88 512	20
9	Cup nut	210 123	1
*11	'F' washer	210 243	1
*13	'M' washer	210 244	1
14	Cartridge	210 245	1
16	Plug	209 859	4
17	Ball location	209 857	4
* 18	Ball, model Ø 30 (st steel 420C)	87 330	4
* 19	Seat	209 858	4
20	Screw, model st steel CHc M 8x70	88 905	16
21	Inlet - Outlet flange	210 255	2
23	Upper body	209 863	1
25	Cylinder	209 856	1
26	Piston rod	209 851	1
* 28	Piston aircap	209 852	1
30	Connecting tube	209 861	2
32	Nut, model st steel M 18	88 598	1
33	Support washer	209 854	1
34	Screw, model st steel HM 8x20	88 500	4
35	Valve box	209 860	2
36	Lower body	209 855	1
38	Lock nut	88 907	4
39	Screw	88 280	1
40	Terminal	209 870	1
*	Package of seals	Depending upon choice (Refer to chart) (Ind. 8x9, 10, 12, 15, 22x4, 24x2, 27x4, 31)	1

* Preceding the index number denotes a suggested spare part.

N S S : Denotes parts are not serviceable separately.

■ PACKAGE OF SEALS COMPOSITION

# FLUID SECTION		105 340 0101			105 340 0102			105 340 0103		
Package code : #		01 105 766			02 105 947			03 106128		
Ind.	Description	Qt	#	Material	Qt	#	Material	Qt	#	Material
* 8	O-Ring	9	80027	FPM	9	85527	EPDM	9	80027	FPM
* 10	Spacer	1	210247	PEEK	1	210247	PEEK	1	210247	PEEK
* 12	Chevron seal	6	210242	PE	3	210438	PTFE	3	210242	PE
					2	210414	LEATHER	2	210414	LEATHER
* 15	O-Ring	1	84052	FPM	1	84414	EPDM	1	84052	FPM
* 22	O-Ring	4	80023	FPM	4	85523	EPDM	4	80023	FPM
* 24	O-Ring	2	84386	FPM	2	84449	EPDM	2	84386	FPM
* 27	O-Ring	4	80021	FPM	4	85521	EPDM	4	80021	FPM
* 31	Piston seal	1	209853	PE	1	209853	PE	1	209853	PE



	PE	→	^	PTFE	→	^	PE	→	^
	PE	→	^	LEATHER	→	^	LEATHER	→	^
	PE	→	^	PTFE	→	^	PE	→	^
	PE	→	^	LEATHER	→	^	LEATHER	→	^
	PE	→	^	PTFE	→	^	PE	→	^
	PE	→	^						
	PE	→	—	PE	→	—	PE	→	—

■ PACKAGES OF SEALS RECOMMENDED

Code	Composition	Use
01	PE cup seals FPM/VITON O-Rings	Water based materials
02	PTFE/Leather cup seals EPDM O-Rings	Solvented materials
03	PE/Leather cup seals FPM/VITON O-Rings	Water based materials