

sames  kremlin



# Nanogun+ Airspray – GNM 6080

LR- HR- MR Versions

Instruction manual

**DRT7105**

G - 2022/11

**Sames**

13, Chemin de Malacher - 38240 MEYLAN - FRANCE  
Tel. 33 (0)4 76 41 60 60

All communication or reproduction of this document, in any form whatsoever and all use or communication of its contents are forbidden without express written authorisation from **Sames**.

The descriptions and characteristics mentioned in this document are subject to change without prior notice

© **Sames 2014 - translated of the original version**

**Sames** operating manuals are written in French and translated into English, German, Spanish, Italian and Portuguese. The French version is deemed the official text and **Sames** will not be liable for the translations into other languages.

## Services



### Certification and referencing

**Sames** is certified as a training center by the DIRRECTE of the Auvergne Rhône Alpes region under the number 84 38 06768 38.

Our company provides, throughout the year, training courses allowing you to acquire the essential know-how for the implementation and maintenance of your equipment in order to guarantee its performance in the long term.

A catalog is available on request.

[www.sames.com/france/fr/services-training.html](http://www.sames.com/france/fr/services-training.html)



### Line audits

As part of a technical assistance program for our customers using **Sames** equipment, the line audits are intended to help you optimize and control your production tool.

Our network of experts is continuously trained and qualified to provide our customers with technical expertise on the liquid or powder installations in which our equipment is integrated. The global environment of the production lines is taken into account during this technical audit.

A brochure is available for download:

[www.sames.com/france/fr/services-service-contract.html](http://www.sames.com/france/fr/services-service-contract.html)



### Maintenance program

An annual maintenance program (including or not the consumables to be replaced during each intervention) can be considered with the partnership of **Sames**. It is associated with a preventive maintenance plan established during a first audit visit which details the control points necessary to guarantee the performance of the installed equipment.

[www.sames.com/france/fr/services-service-contract.html](http://www.sames.com/france/fr/services-service-contract.html)



### Hotline

[www.sames.com/france/fr/services-service-contract.html](http://www.sames.com/france/fr/services-service-contract.html)

---

# Nanogun+ Airspray – GNM 6080

1. Health and Safety Instructions – – – – –	6
1.1. Marking .....	6
1.1.1. By the barrel.....	6
1.1.2. On the lower part of the gun handle.....	6
1.2. GNM 6080 control module .....	7
1.3. Precautions for use .....	8
1.4. Meaning of pictograms .....	9
1.5. Warnings .....	10
1.6. Regulations .....	10
1.7. Installation rules .....	11
1.8. Operating rules .....	12
1.9. Maintenance rules .....	14
1.9.1. Products used.....	15
1.10. Guarantee .....	16
2. Description of spray gun and GNM 6080 control module – – – – –	17
2.1. Functions available on spray gun .....	17
2.2. GNM 6080 Control module .....	18
3. Technical characteristics – – – – –	21
3.1. General spray gun characteristics .....	21
3.2. GNM 6080 Characteristics .....	22
3.3. Operation .....	23
3.4. For use .....	23
3.4.1. Viscosity.....	23
3.4.2. Resistivity .....	23
3.4.3. Settings of the spraying parameters .....	23
4. Electric diagrams – – – – –	27
4.1. Connection cable GNM 6080 / Nanogun+ Airspray .....	27
4.2. GNM 6080 trigger cable .....	27
5. Start-up – – – – –	28
5.1. Special tools .....	28
5.2. Using the multipurpose spanner .....	29
5.3. Installation .....	30
5.3.1. With piston pump for all versions.....	30
5.3.2. With diaphragm pump for all versions .....	31
5.3.3. With a pressure tank for all versions .....	32
6. Maintenance – – – – –	33
6.1. Summary table of maintenance operations .....	33
6.2. Preventive maintenance plan – PMP 7105 .....	34
6.3. Cleaning .....	34
6.3.1. Procedure A1 : Cleaning the product circuit.....	34
6.3.2. Procedure A2 : Cleaning the spray gun .....	35
6.3.3. Procedure A3: Waste disposal.....	35
6.3.4. Procedure A4: Demolition and Recycling .....	36
6.4. Replacement .....	39
6.4.1. Procedure B1: Replacement of the paint hoses.....	39

6.4.2. Procedure B2: Replacement of the spray head assembly.....	41
6.4.3. Procedure B3: Replacement of the paint needle.....	42
6.4.4. Procedure C1: Replacement of O-rings and seals.....	45
6.4.5. Procedure C2: Replacement of the air valve.....	47
6.4.6. Procedure C3: Replacement of the high voltage cascade.....	49
6.4.7. Procedure D1: Replacement of the electropneumatic coupling.....	50
6.4.8. Procedure D2: Remove paint hose. Loosen the paint hose nut with a 15mm open-ended spanner.....	51
6.4.9. Procedure D3: Replacement of the switch.....	52
6.4.10. Procedure D4: Replacement of the trigger.....	52
6.4.11. Procedure D5: Replacement of the fixing hook.....	53
7. Troubleshooting Guide -----	54
8. Spare Parts -----	56
8.1. Nanogun+ Airspray spray guns low pressure for high resistivity (HR) solvent paint $\rho > 10M\Omega cm$ .....	57
8.2. Nanogun+ Airspray, low Pressure spray guns for solvent paint $0.5 M\Omega cm < \rho < 500 M\Omega cm$ .....	59
8.3. Nanogun+ Airspray, low Pressure spray guns for solvent paint $2 M\Omega cm < \rho < 500 M\Omega cm$ .....	60
8.4. Nanogun+ Airspray spray guns, all versions .....	61
8.5. Barrel assembly.....	63
8.6. Air valve and air valve nut .....	64
8.7. Air cap ring .....	65
8.8. Nozzle support .....	65
8.9. Round Nozzle assemblies - LP Models .....	66
8.10. Needle assembly .....	67
8.11. Electropneumatic coupling sets .....	67
8.12. Paint hoses .....	68
8.12.1. For Nanogun+ Airspray Low Pressure and High Resistivity spray guns .....	68
8.12.2. For Nanogun+ Airspray Low Pressure and Low Resistivity spray guns.....	68
8.12.3. For Nanogun+ Airspray Low Pressure and middle Resistivity spray guns .....	69
8.13. Nanogun+ Airspray seal set .....	70
8.14. GNM 6080 Control module .....	70
8.15. Options for Nanogun+ Airspray Low Pressure spray guns .....	71
8.15.1. Flat Spray Air Caps.....	71
8.15.2. In-line product filters.....	71
8.16. Various .....	72
8.16.1. Protective hose covering.....	72
8.16.2. Protective case for spray gun .....	72
8.16.3. Warning notice.....	72
8.16.4. Safety valve.....	72
9. The different versions -----	73
9.1. Equipments .....	73
9.2. Configuration .....	75
10. Revision index History -----	76
11. Appendices -----	77
11.1. Preventive maintenance plan .....	77
11.2. EU and UK declarations of conformity .....	78

## 1. Health and Safety Instructions

### 1.1. Marking

The various markings on Nanogun+ Airspray spray guns can be used to identify whether low pressure (LP) configuration is being used.

#### 1.1.1. By the barrel

All Nanogun+ Airspray range products carry the same markings on the barrel.

The equipment is designed in accordance with ATEX Directive 2014/34/EU and SI 2016 No. 1107, is Category 2, and is intended for use in Zone 1.

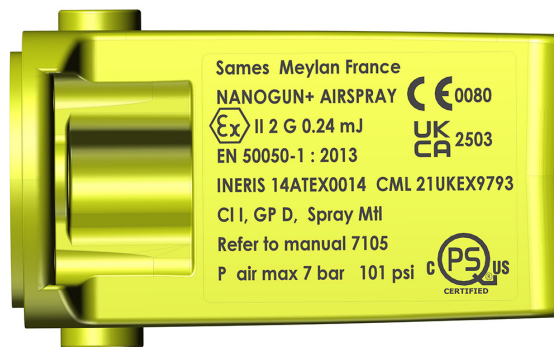

#### 1.1.2. On the lower part of the gun handle



This marking groups together all spray gun configurations operating at the same product pressure under the same number.

Marking no.	Product pressure	Nanogun+ Airspray models
910015741	7 bar	JR06-LR; JR06-MR; JR06-HR JR08-LR; JR08-MR; JR08-HR JR12-LR; JR12-MR; JR12-HR JP-LR; JP-MR; JP-HR

### 1.2. GNM 6080 control module

The GNM 6080 control module should not be installed in an ATEX zone (potentially explosive atmosphere). It is defined as “associated material” according to ATEX Directive 2014/34/EU and SI 2016 No. 1107.

#### Markings

**EU / UK versions**

Sames Meylan France

GNM6080  
910017193

CE 0080 UKCA 2503

IP20

88 - 264V~ 50/60Hz 25VA  
U output : 40V rms  
I output : 200mA rms

II (2) G  
INERIS14ATEX0014  
[0,24mJ]  
CML21UKEX9793  
EN 50050-1:2013

Admissible combinations of devices,  
see information for use

2022 26123 \*

Version Software:  
S/N :

DE508772

**US / C versions**

Sames Meylan France

GNM6080  
910017192

IP20

88 - 264V~ 50/60Hz 25VA  
U output : 40V rms  
I output : 200mA rms

PS US  
CERTIFIED

2022 26123 \*

Version Software:  
S/N :

DE508773

**Example: \* 2022: Year of manufacturing**

**26: Week number**

**123: Nth control module made in the week 26.**



Equipment Nanogun+ Airspray is in accordance with the functional safety standard (Standard EN13849, level SIL 1), the preservation of this level of safety imposes a periodic control of the equipment, in minima every 5 years or 15000 hours of functioning (to the first one 2 reached). This control concerns each of the electric and electronic components as well as on it or the very specific programs, you have to get in contact with your subsidiary, distributor or usual representative of Sames who will indicate you the steps to be carry out.

### 1.3. Precautions for use

This document contains information that all operators should be aware of and understand before using the **Nanogun+ Airspray**. This information highlights situations that could result in serious damage and indicates the precautions that should be taken to avoid them.



**Before any use of the Nanogun+ Airspray spray gun, check that all operators:**

- have previously been trained by the company **Sames**, or by their distributors registered by them for this purpose.
- have read and understood the user manual and all rules for installation and operation, as listed below.

**It is the responsibility of the operator's workshop manager to ensure these two points and it is also his responsibility to make sure that all operators have read and understood the user manuals for any peripheral electrical equipment present in the spraying area.**



1.4. Meaning of pictograms

				
Warning electricity	Warning Automatic start-up	Warning Hot surface	Warning Explosive material	General warning sign
				
Warning High pressure	Warning Crushing of hands	Warning for explosive atmospheres	Warning Flammable material	No access for people with active implanted cardiac devices
				
Wear ear protection	Wear a face shield	Wear respiratory protection	Wear safety footwear	Wear protective clothing
				
Wear head protection	Opaque eye protection must be worn	Wear protective gloves	General mandatory action sign	Connect an earth terminal to the ground
				
Refer to Instruction manual				

## 1.5. Warnings



It is imperative that anyone wearing a pacemaker does not use the equipment and does not enter the projection area.  
High voltage can cause the pacemaker to malfunction.



This equipment may be dangerous if not used, disassembled and reassembled in accordance with the rules specified in this manual and any applicable European Standard or national safety regulations.  
The warning notice summarizing the safety rules (procedures and precautions) laid out in this instruction manual must be clearly displayed in the area of the spraying workstation.



The correct operation of the equipment is guaranteed only with the use of original spare parts distributed by Sames.



In order to ensure optimum assembly, spare parts should be stored at a temperature close to their operating temperature. If not, a sufficient waiting time must be observed before installation, so that all parts are assembled at the same temperature.

## 1.6. Regulations

The **Nanogun+ Airspray** spray gun must always be used according to the requirements stipulated in the standards and regulations in force concerning painting and clear coat methods (see Standards and Directives EN 50.053 part 1 ISO 12100, EN 1953 and 99/92/CE).

In **Canada**, the installation has to be in compliance with the code "electrical C22.1 Canadian code, part I, standard safety for electrical installations".

In the **USA**, the installation has to be in compliance with the code "NFPA 70: National Electrical Code".

CAUTION: Model **Nanogun+ Airspray** spray applicator is suitable for use in **CLASS I, DIVISION 1, GROUP D HAZARDOUS LOCATIONS** when connected to model GNM 6080 power supply unit.

The Pollution Degree Rating of the **Nanogun+ Airspray** is "Pollution Degree 2" following IEC-664-1 standard.

**Pollution Degree 2:** Normally only non-conductive pollution occurs. Temporary conductivity caused by condensation is to be expected.



**Before any use of the Nanogun+ Airspray spray gun, check that all operators:**

- have previously been trained by the company or by their distributors registered by them for this purpose.
- have read and understood the user manual and all rules for installation and operation, as listed below.

**It is the responsibility of the operator's workshop manager to ensure these two points and it is also his responsibility to make sure that all operators have read and understood the user manuals for any peripheral electrical equipment present in the spraying area.**

### 1.7. Installation rules

- The manual projection electrostatic material must be used only in projection area according to the standard EN 16985 or in equivalent conditions of ventilation.
- The control module must **not be installed where there is a potential explosion risk**.
- It must be impossible to start up the control module before the spray booth air extraction system is in operation.
- Connect the control module correctly to the earth terminal of the installation to avoid electromagnetic interference. The resistance between the module's earth and the installation's earth should be as low as possible, in the order of a few ohms.
- The paint (or solvent) pump and tank must be connected to a ground terminal on the device.
- All metal parts of the apparatus (paint pumps, containers, stools, turntables, etc.) less than three metres from the spray gun must be grounded.
- The spraying area must be kept clean and clear of any unnecessary items.
- The floor on which the operator works must be dissipator (bare concrete or metal duckboard). Never use an insulating floor covering. In area potentially explosive, the assemblies of grounds have to be dissipators according to the standard EN 61340-4-1.
- Naked flames, glowing objects or a devices likely to produce sparks (other than the atomizer) must not be used inside the booth.  
The storage of inflammable products, or vessels that have contained them, close to the booth or in front of the doors is prohibited.
- Pots and tubs containing paint or solvent must always be closed after use.
- The paint supply pump used must have a maximum ratio of 1:1 and the pump air supply must be fitted with a safety valve limiting the pressure to 6.5 bar maximum.
- **In the explosive area**, it is forbidden to use any non-certified electrical or non-electrical equipment such as electronic extension leads, multiple socket adapters, switches, etc.

## 1.8. Operating rules

- The ventilation system must be checked on a daily basis to ensure it is working properly.
- Performance checks must be carried out on the extraction control system once a week.
- Before starting to spray, check that the nozzle/tip and air cap are fitted to the gun and that the air cap ring is fully tightened.
- All metal parts of the booth and parts to be painted must be correctly grounded. Ground resistance must be less than or equal to 1 MΩ. (measurement voltage 500 V). This resistance value must be regularly checked.
- The operator must wear dissipator shoes according Standard EN 61340-4-3 and hold the **Nanogun+ Airspray** spray gun bare-handed or with gloves that are either dissipators or specially adapted to allow direct contact between the handle and the operator's hand. Shoes intended to be worn by the operator have to be in accordance with the standard ISO 20344. The measured insulating resistance does not have to exceed 100 MΩ.
- Protective clothings intended to be worn, including gloves, have to be in accordance with the standard EN 1149-5. The measured insulating resistance does not have to exceed 100 MΩ..
- The operator must also wear ear defenders when using **Nanogun+ Airspray** spray guns ([see § 1.3 page 8](#)).
- Ensure that anyone who enters the spraying area is wearing dissipator shoes or is otherwise grounded.
- Never throw or drop deliberately the electrostatic spray gun. Dropping the gun could damage the high voltage generator. After a drop, it is advised to verify the functioning of the pistol out off zone before its re-use.
- Never point the spray gun towards a person.
- Check the spray gun at least 1 time a week.
- Never use the apparatus in the following situations:
  - 1 If you notice an air leak from the spray gun when the trigger is released.
  - 2 If the spray gun electrical connector catch is not held securely in place with two safety screws.
  - 3 If the spray gun barrel, handle show signs of an impact that may have deteriorated the air-tightness of internal components.
- The manual electrostatic projection equipment must be exploited only if it is in a perfect state. A damaged equipment must be immediately removed from the installation and must be repaired. The worn out components must be immediately replaced.
- Follow the precautions specified for the paints and solvents used (e.g. wear a mask etc.).
- Close and dump the air and paint supply before leaving the device shut down for an extended period.
- Check the paint hose is in good condition before starting to operate the device.
- The electropneumatic coupling, held in place by two safety screws **MUST NEVER BE DISCONNECTED IN A POTENTIALLY EXPLOSIVE ATMOSPHERE.**
- If any of the following elements are damaged, all operations with the device must be stopped: barrel, handle, electropneumatic coupling, air cap or air cap ring.



Sames would like to remind users that the instructions below **MUST** be strictly complied with.

<b>It is forbidden</b> to install the control module in a potentially explosive atmosphere.
<b>It is forbidden</b> to subject the paint or air hose or spray gun power cable to excessive and repeated tension strain.
<b>It is forbidden</b> to disconnect the electrical connector in a potentially explosive atmosphere.
<b>It is forbidden</b> to leave air or paint hoses trailing on the floor or in areas where they are liable to be crushed or broken by industrial vehicles.
<b>It is forbidden</b> to use the <b>Nanogun+ Airspray</b> to spray a liquid other than a paint or clear coat.
<b>It is forbidden</b> to drop the spray gun or subjecting it to impacts.
<b>It is forbidden</b> to leave the spray gun on the ground.
<b>It is forbidden</b> to use the spray gun to handle or move the parts to be painted.
<b>It is forbidden</b> to leave the spray gun to soak in solvent or spraying it with solvent.
<b>It is forbidden</b> to spray solvent before switching off the control module.

<b>It is essential</b> to connect the control module ground terminal to the paint apparatus ground terminal.
<b>It is essential</b> to tighten the two safety screws on the electrical connector.

## 1.9. Maintenance rules



During the 12-month warranty period, it is strictly forbidden to dismantle the Nanogun+ Airspray gun except to carry out maintenance in accordance with the maintenance instructions ([see § 6 page 33](#)).

- Service regularly and repair the electrostatic spraying equipment in accordance with the instructions in this user manual.
- Metal containers only should be used to hold cleaning liquids and they must have a reliable ground connection.
- Before any maintenance or servicing operation:
  - 1 Disconnect the control module from the power supply.
  - 2 Check that the air and paint circuits are not pressurized.
  - 3 Dump the paint Circuit
  - 4 All the energy sources must be consigned.
- Cleaning operations must be carried out either in authorised areas equipped with a mechanical ventilation system, or using cleaning liquids with a flash point at least 15 °C higher than the ambient temperature.
- Use non flammable cleaning products preferably.
- Do not reconnect the electrical power supply until the air cap and nozzle/tip have been correctly reassembled on the spray gun.
- Never soak or immerse the spray gun in solvent. If required, the spray gun may be cleaned by wiping with a cloth soaked in solvent and then immediately dried to prevent the solvent entering the spray gun.



**Never spray solvent whilst the control module is live and/or the switch located on the back of the gun is in position «I».**



**The cut of the compressed air supply does not prohibit the release of the high voltage when the trigger is activate.**

- Operators must be trained by **Sames**, or by their distributors registered by them for this purpose, to perform **Nanogun+ Airspray** spray gun maintenance operations.



**It is forbidden to use oil-based solvent and products containing such solvents if aluminium or zinc are present. Users who do not follow these instructions are exposed to explosion risks.**

### 1.9.1. Products used

Given the wide range of products used, and that fact that it is impossible to produce an inventory of these products, **Sames**, cannot be held liable for:

- incompatibility of product material used when in contact with materials listed below:
  - Stainless steel
  - Fluoroethylenepropylene (FEP)
  - Polyamide-imide (PAI)
  - Polyoxymethylene (POM)
  - Tungsten carbide and Tungsten
  - PTFE elastomer
  - Polypropylene
  - IXEF
  - Glass fibre
  - Ceramics
  - Aluminium
  - Titanium
  - PEEK
  - PEHD and PEBD
  - Chemically inert rubber
- Risks related to the use of these products for personnel and the environment include.
- Wear, incorrect adjustments or malfunction of equipment or machines, together with the non-quality of the application caused by the use of these products.

### 1.10. Guarantee

Under the guarantee, which applies only to the buyer, **Sames** agrees to repair operating faults resulting from a design fault, materials or manufacture, under the conditions set out below.

The guarantee claim must define, in writing, the exact nature of the fault concerned.

The **Sames** guarantee only covers equipment that has been serviced and cleaned according to standard procedures and our own instructions, that has been fitted with parts approved by **Sames** or that has not been modified by the customer.

More precisely, the guarantee does not cover damage resulting from:

- the customer's negligence or inattentiveness,
- incorrect use,
- failure to follow the procedure
- use of a control system not designed by **Sames** or a **Sames** control system modified by a third party without written permission from an authorized **Sames** technical agent,
- flooding, earthquake, fire or similar events,
- inadequately filtered paint and solvent,
- use of seals not complying with Sames recommendations,
- pollution of air circuits by fluids or substances other than air.

The **Nanogun+ Airspray** guns are covered by a one-year guarantee for use in two 8-hour shifts under normal operating conditions (5000 hours).

The guarantee does not apply to wearing parts such as nozzles, seals, etc...

The guarantee will start from the date of the first use or the provisional acceptance report.

Under no circumstances, either in the context of this guarantee or in other contexts, will Sames be held responsible for physical injury or intangible damage, damage to brand image and loss of production resulting directly from its products.



## 2. Description of spray gun and GNM 6080 control module

**Nanogun+ Airspray** spray guns are designed to spray paint or clear coat whose resistivity is greater than 0.5MΩ.cm. only.

The configurations LR can moreover spray hydrodiluable paints or clear coats when they are equipped with the suitable produced means of supply. The use of any other type of paint is excluded.

**Nanogun+ Airspray** spray guns are to be connected to the **GNM 6080** control module.

The models in the **Nanogun+ Airspray** range can be differentiated by their air cap, air cap ring, the base support and the paint hose.

	Characteristics
<b>Nanogun+ Airspray JR06</b>	Super Vortex Round Spray - Low Pressure - Ø 6 mm
<b>Nanogun+ Airspray JR08</b>	Super Vortex Round Spray - Low Pressure - Ø 8 mm
<b>Nanogun+ Airspray JR12</b>	Super Vortex Round Spray - Low Pressure - Ø 12 mm
<b>Nanogun+ Airspray JP</b>	Flat Spray - Low Pressure

### 2.1. Functions available on spray gun

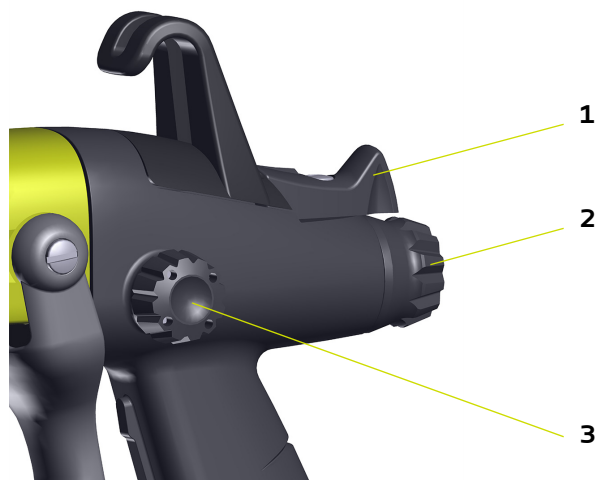

- The switch (1) allows to start or to cut the high voltage.  
When this switch is on the position " I ", an action on the trigger starts up the high voltage.  
When this switch is on the position " 0 ", an action on the trigger does not start the high voltage.
- The notched button on the back of the gun (2) allows to regulate the product flow.
- The side notched button (3) allows to regulate the dimension of the spray.

## 2.2. GNM 6080 Control module

The GNM 6080 control module allows the display of the parameters of use as well as their adjustments.

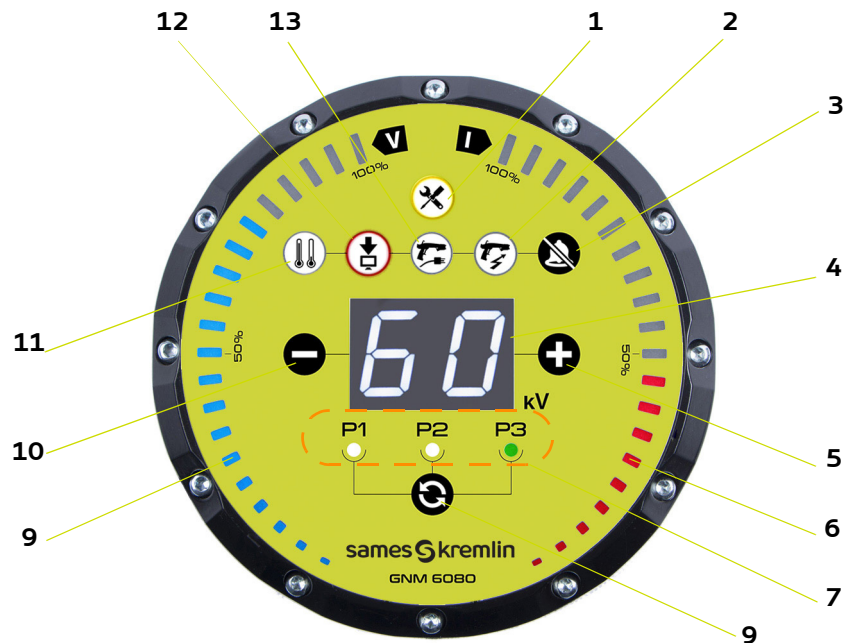

Front face of the GNM 6080 control module

1	Maintenance indicator light
2	Indicator light of high voltage fault
3	Reset of faults
4	Display of setpoint of high voltage
5	Increase of the setpoint voltage
6	Bargraph of the current consumption
7	Indicator lights of active preset memory
8	Selection of the active memory
9	Bargraph of the voltage
10	Decrease of the setpoint voltage
11	Indicator light of temperature fault
12	Indicator light of control module fault
13	Indicator light of low voltage cable



Temperature fault : The temperature fault forces the indicator lights (**11 and 12**). As soon as the temperature decrease under the minimum, the temperature indicator light (**11**) goes out and the operator can delete the fault by pressing on the button «Reset of faults» (**3**).



Control module fault: this fault collects all the internal faults of the control module. If this fault can not reseted, the problem requires the intervention of the repair department, contact **Sames**.



**Low voltage connection fault:**

- The control module does not detect or any more the presence of the gun.
- Switch off the main power supply, check the connection between the control module and the gun.
- This fault may also be related to electromagnetic interference generated by other equipment in the installation.
- Check that the module is earthed and that the other equipment complies with electromagnetic compatibility rules.

**Nota:** One or more alarm lights come on at random and sometimes it is impossible to acknowledge them, and/or the red and blue LED strips do anything when the trigger is pulled and/or nothing happens when the trigger is pulled.

**Remedies:**

Turn off the GNM and turn it back on 2 or 3 seconds later, this can be repeated 2, 3 or 4 times if it doesn't work. If it still doesn't work: Check the electronic disturbance in the vicinity of the module and the ground of the building to which the module is connected.



**High voltage faults:** faults specific to the operation of the gun related to the high voltage:

- Start up of the control module with the engaged trigger.
- Peak of an important over-current during the high voltage.
- Bad functioning of the high voltage unit.



**Maintenance indicator light:** This indicator light ignites (orange) from 800000 operations of the trigger or at the 1000 hours of functioning of the gun ([see § 6 page 33](#)).

The ignition of this light indicates that the maintenance of the gun must be carried out. No specific maintenance on the GNM 6080.

If one or more lights or barographs come on at random, after switching off the power supply to the module,

it is necessary to check that the module is earthed and that other equipment complies with electromagnetic compatibility regulations.

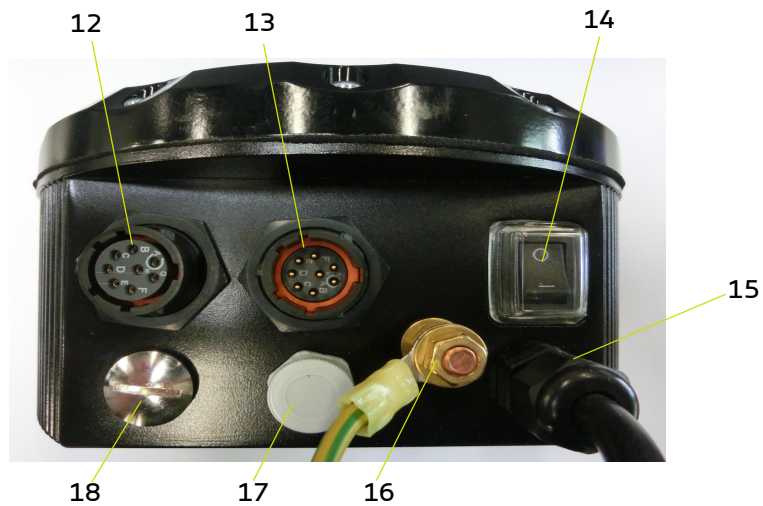

Side face of the GNM 6080 control module

<b>12</b>	Plug for gun cable
<b>13</b>	Plug for external cabling
<b>14</b>	Switch ON / OFF
<b>15</b>	Main power supply
<b>16</b>	Ground connection
<b>17</b>	Diaphragm of pressure balancing
<b>18</b>	Diagnosis plug (type mini USB)

### 3. Technical characteristics

#### 3.1. General spray gun characteristics

	JR06	JR08	JR12	JP
Spray type	Round Super Vortex	Round Super Vortex	Round Super Vortex	Flat spray
Air cap fitted as standard	JR06	JR08	JR12	P15
Max. paint intake pressure	7 bar	7 bar	7 bar	7 bar
Compressed-air intake pressure	6 bar $\pm$ 1 bar			
Mini/ maxi ambient temperature	0°C - 40°C			
Max. paint flow rate (paint viscosity 20s when measured with AFNOR Cup 4) in cm <sup>3</sup> /min	650	650	750	750
Spray width, 25 cm away	19 cm	20 cm	21 cm	37 cm
Air flow rate Nm <sup>3</sup> /h	6.6 - 16.8	7.8 - 16.8	9.4 - 22.5	10,3 - 25,2
Sound pressure (*)	93.8 dB(A)	93.8 dB(A)	93.8 dB(A)	98.6 dB(A)
Recommended paint viscosity (measured with AFNOR Cup 4)	14 to 50 s			
Dimensions	273 x 220 x 52			
Weight without hoses or cables	570 g			
Output voltage	Max. 60 kV [+0 kV; -1,5 kV] (adjustable on GNM 6080)			
Output current	80 $\mu$ A max.			
Short-circuit output current	< 20 $\mu$ A			
HV cascade input voltage	45 V AC max.			
HV cascade input current	300 mA max.			
Air coupling	1/4 NPS - F			
Paint fitting	1/2 JIC - M			
Paint resistivity $\rho$	10 M $\Omega$ .cm < $\rho$ < 500 M $\Omega$ .cm QD Version (high resistivity) 0.5 M $\Omega$ .cm < $\rho$ < 500 M $\Omega$ .cm LR Version (low resistivity) 2 M $\Omega$ .cm < $\rho$ < 500 M $\Omega$ .cm LR Version (middle resistivity)			
Electrical functions available on the gun	High voltage ON / OFF switch			
Electrical / pneumatic connector	The electropneumatic coupling, held in place by two safety screws <b>MUST NEVER BE DISCONNECTED IN A POTENTIALLY EXPLOSIVE ATMOSPHERE</b>			
Altitude	2000 m maxi.			
Maximum relative humidity for temperatures up to 80% decreasing linearly to 50% relative humidity at 40°C.	Maximum 80% relative humidity, non-condensing			
Surface temperature	T6			
Index of protection	IP 20			
<b>Transportation / Storage</b>				
Time of storage	2 years max.			
Temperature of mini / maxi storage	-10°C + 45°C			
Humidity	95% without condensation			
Mini pressure	750 mBar			
Exposure to the UV radiations	Stored shielded from the light			
Exposure to the ionizing radiations	No admitted			
<b>Compressed air (according to Standard NF ISO 8573-1)</b>				
Maximum dew point at 6 bar (87 psi)	Class 4, i.e. + 3 °C (37° F)			
Maximum particle size of solid contaminants	Class 3, i.e. 5 $\mu$ m			
Maximum oil concentration	Class 1, i.e. + 0.01mg/m <sub>0</sub> <sup>3</sup> *			
Maximum concentration of solid contaminants	5 mg/m03 *			

(\*) The weighted equivalent continuous sound pressure level is between 93.8 et 98.6dBA, depending on spray gun version.

(\*\*) Values are given for a temperature of 20 ° C (68 °F) at 1013 mbar atmospheric pressure.

**Measurement conditions:**

The apparatus was operated to maximum capacity and the measurements taken in the manual paint test booth (sealed booth with glass panels) located in the **Sames** site in Meylan, France.

**Measurement method:**

The weighted equivalent sound pressure level (93.8 et 98.6 dBA) is an LEQ value measured during observation periods over at least 30 seconds.

**3.2. GNM 6080 Characteristics**

Installation category II (according to EN 61010-1).

<b>General</b>	
Weight	1.7 kg
Dimensions	Diameter: 168 mm
	Height: 91 mm
Operating temperature	0-40°C
<b>GNM 6080 Input</b>	
Voltage	88 - 264 V AC
Frequency	50 - 60 Hz
Max. current	0,25 A
Max. power	25 V.A
<b>GNM 6080 output</b>	
Voltage	40 V rms
Current	200 mA rms



**The GNM 6080 automatically adapts to the supply voltage.**

### 3.3. Operation

Pressing the trigger controls non-simultaneous opening of the air valve then engaging of high voltage and then the paint needle. The high voltage pilot can be disabled by using the switch on the gun.

**Nanogun+ Airspray** spray guns are fitted with a magnetic sensor which detects the position of the trigger. This sensor allows to supply the high-voltage as soon as the air valve of air moves back of a value between 1 and 1,8 mm:

- The button at the rear of the spray gun allows to adjust the paint flow.
  - Selector fully turned to the left: max. spray flow.
  - Selector fully turned to the right: reduced paint flow.
- The side button allows to adjust the spray.
  - Tighten screw: reduced impact.
  - Loosen screw: wide impact.

### 3.4. For use

Paint Recommendations

In general, all paints and clear coats used with conventional pneumatic spray guns (including slightly metallic paints) can be used in the normal way with the **Nanogun+ Airspray** spray gun.

#### 3.4.1. Viscosity

The best results are obtained with a viscosity ranging from 25 to 30 seconds, measured with AFNOR cup 4. However, paints with a lower or higher viscosity (for example 14 to 50 seconds or more) can be sprayed.

#### 3.4.2. Resistivity

Use a paint whose resistivity is suitable for the **Nanogun+ Airspray** spray gun model that you are using. Optimum resistivity ranges from 0.5 to 500 MΩ.cm. Low resistivity promotes a good wraparound effect, but there may be back spray onto the operator if the booth is inadequately ventilated, especially when using the round spray.

Much lower resistivity (for example 0.1 MΩ.cm) will short circuit the high voltage and therefore prevent any wraparound effect. High resistivity (e.g. 1000 MΩ.cm) will significantly reduce the wraparound effect which will be greatly reduced. Paint resistivity can be easily checked using the **Sames AP 1000** resistivohmmeter.

#### 3.4.3. Settings of the spraying parameters

These settings are given for information and can be subject to variations in particular due to the temperature and to the ambient humidity.

**Viscosity of paint 20 sec CA4 and length of paint hose 7.5 m:**

Flat spray nozzle with high efficiency cap ring (P/N 900009014)	Paint flow in cc/min	130	285	525	750	900
	Paint pressure in bar	0.3	0.8	1.5	2.6	3.1
	Air compressed flow in Nm <sup>3</sup> /h	10.3	15.8	19.4	25.2	30
	Air compressed pressure in bar *	1.4	2.4	3.1	4.2	6
	Width of spray in cm**	11	24	35	37	37
	Finishing	Good	Good	Good	Good	Average
Round spray nozzle Ø: 6 mm	Paint flow in cc/min	70	200	400	650	
	Paint pressure in bar	0.4	1	2	4	
	Air compressed flow in Nm <sup>3</sup> /h	6.6	7.8	12.2	16.8	
	Air compressed pressure in bar *	1.2	1.5	2.7	4	
	Width of spray in cm**	8	8	15	19	
	Finishing	Good	Good	Good	Good	
Round spray nozzle Ø: 8 mm	Paint flow in cc/min	120	150	315	660	
	Paint pressure in bar	0,2	0,3	0,6	1,5	
	Air compressed flow in Nm <sup>3</sup> /h	6.6	7.8	11.3	16.8	
	Air compressed pressure in bar *	1	1.3	2.1	3.4	
	Width of spray in cm**	8	9	11	20	
	Finishing	Good	Good	Good	Good	
Round spray nozzle Ø: 12 mm	Paint flow in cc/min	135	150	310	660	
	Paint pressure in bar	0.2	0.3	0.6	1.5	
	Air compressed flow in Nm <sup>3</sup> /h	8.4	9.4	12.8	22.5	
	Air compressed pressure in bar *	1.2	1.5	2.2	4.3	
	Width of spray in cm**	NS***	11	13	21	
	Finishing	Good	Good	Good	Good	

- \* Dynamic pressure measured in the inlet of the supply hose of compressed air when the spray gun is in use.
- \*\* Maximum size of the spray when the circuit of additional air is opened at most with a distance of 250 mm spraying and a electrostatic tension of 60 kV.
- \*\*\* Too low flow, coat not closed considering the time of spraying.



**Viscosity of paint 50 sec CA4 and length of paint hose 7.5 m:**

Flat spray nozzle with high efficiency cap ring (P/N 900009014)	Paint flow in cc/min	120	285	495	750	915
	Paint pressure in bar	0.75	1.8	3.2	5	6.5
	Air compressed flow in Nm <sup>3</sup> /h	10,3	15.8	19.4	25.2	30
	Air compressed pressure in bar *	1.4	2.4	3.1	4.2	5.5
	Width of spray in cm**	11	24	35	37	37
	Finishing	Good	Good	Good	Good	Average
Round spray nozzle Ø: 6 mm	Paint flow in cc/min	The use of a 6 mm injector to spray a viscous product is not advised.  Only ones of the tests of spraying allow to determine the values of pressure product and compressed air to apply.				
	Paint pressure in bar					
	Air compressed flow in Nm <sup>3</sup> /h					
	Air compressed pressure in bar *					
	Width of spray in cm**					
	Finishing					
Round spray nozzle Ø: 8 mm	Paint flow in cc/min	140	300	640		
	Paint pressure in bar	0.9	1.8	3.8		
	Air compressed flow in Nm <sup>3</sup> /h	7.8	11.3	16.8		
	Air compressed pressure in bar *	1.3	2.1	3.4		
	Width of spray in cm**	9	11	20		
	Finishing	Good	Good	Good		
Round spray nozzle Ø: 12 mm	Paint flow in cc/min	150	290	740		
	Paint pressure in bar	0.8	1.6	3.9		
	Air compressed flow in Nm <sup>3</sup> /h	9.4	12.8	22.5		
	Air compressed pressure in bar *	1.5	2.2	4.3		
	Width of spray in cm**	11	13	21		
	Finishing	Good	Good	Good		

- \* Dynamic pressure measured in the inlet of the supply hose of compressed air when the spray gun is in use.
- \*\* Maximum size of the spray when the circuit of additional air is opened at most with a distance of 250 mm spraying and a electrostatic tension of 60 kV.

**Viscosity of paint 50 sec CA4 and length of paint hose 15 m:**

Flat spray nozzle with high efficiency cap ring (P/N 900009014)	Paint flow in cc/min	100	300	500	680
	Paint pressure in bar	1.2	3.2	5.4	7
	Air compressed flow in Nm <sup>3</sup> /h	10.3	15.8	19.4	25.2
	Air compressed pressure in bar *	1.4	2.4	3.1	4.2
	Width of spray in cm**	11	24	35	37
	Finishing	Good	Good	Good	Good
Round spray nozzle Æ: 6 mm	Paint flow in cc/min	The use of a 6 mm injector to spray a viscous product is not advised.  Only ones of the tests of spraying allow to determine the values of pressure product and compressed air to apply.			
	Paint pressure in bar				
	Air compressed flow in Nm <sup>3</sup> /h				
	Air compressed pressure in bar *				
	Width of spray in cm**				
	Finishing				
Round spray nozzle Æ: 8 mm	Paint flow in cc/min	150	300	650	
	Paint pressure in bar	1.7	3.2	6.5	
	Air compressed flow in Nm <sup>3</sup> /h	7.8	11.3	16.8	
	Air compressed pressure in bar *	1.3	2.1	3.4	
	Width of spray in cm**	9	11	20	
	Finishing	Good	Good	Good	
Round spray nozzle Æ: 12 mm	Paint flow in cc/min	150	300	650	
	Paint pressure in bar	1.5	2.9	6	
	Air compressed flow in Nm <sup>3</sup> /h	9.4	12.8	22.5	
	Air compressed pressure in bar *	1.5	2.2	4.3	
	Width of spray in cm**	11	13	21	
	Finishing	Good	Good	Good	

- \* Dynamic pressure measured in the inlet of the supply hose of compressed air when the spray gun is in use.
- \*\* Maximum size of the spray when the circuit of additional air is opened at most with a distance of 250 mm spraying and a electrostatic tension of 60 kV.

## 4. Electric diagrams

### 4.1. Connection cable GNM 6080 / Nanogun+ Airspray

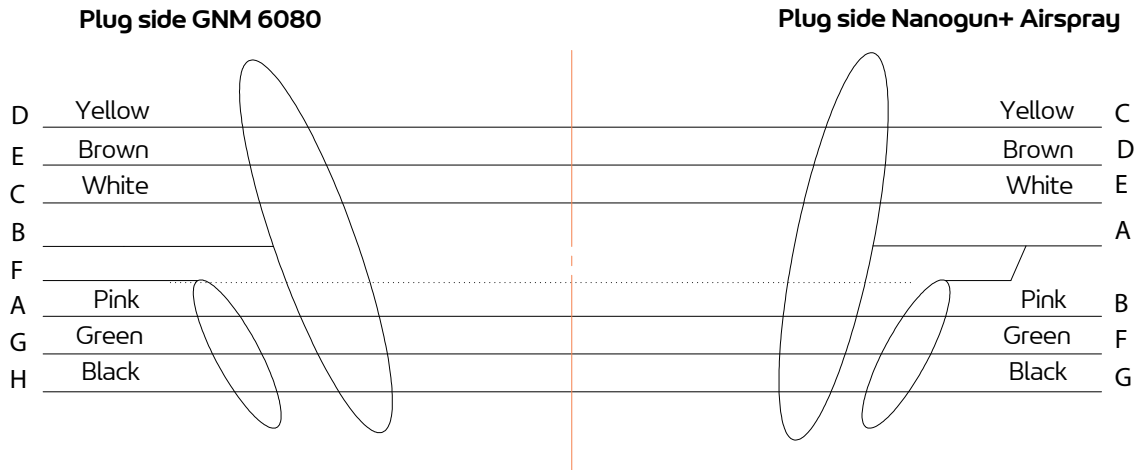

### 4.2. GNM 6080 trigger cable

A	Pink	Primary transformer HVU 3
B		Shield
C	White	REED sensor (trigger)
D	Yellow	Dallas chip
E	Brown	OV commune puce / reed
F		Third shield
G	Green	Primary transformer HVU 3
H	Black	Return IHV 1

Plug side GNM 6080

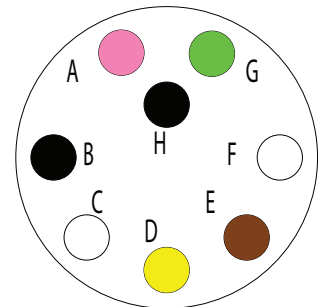

DES06943

(\*)

Switch "open": Nanogun+ Airspray trigger releases.

Switch "closed": Nanogun+ Airspray trigger activated.

Characteristics of the switch: 0.5 A maxi / 24 VAC/DC maxi.

## 5. Start-up

### 5.1. Special tools

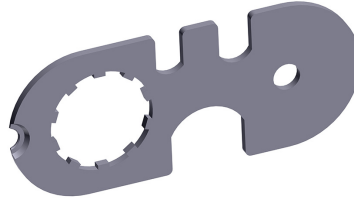

Part number	Description	Qty	Unit of sale
900010674	Multipurpose spanner	1	1

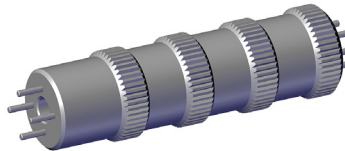

Part number	Description	Qty	Unit of sale
900010973	Disassembly/Reassembly tool for flat nozzle	1	1



Part number	Description	Qty	Unit of sale
H1GMIN017	White vaseline (100 ml)	1	1
H1GSYN037	Dielectric lubricant for high voltage cascade and needle duct (100 g)	1	1



Part number	Description	Qty	Unit of sale
240000301	Seal extractor tool	1	1



Part number	Description	Qty	Unit of sale
129400923	Air cap cleaning brush	1	1

Additional tools and accessories required:

The tools listed below should be available for product installation and maintenance operations.

- Flathead screwdriver (2.5x75; 4x100, 5.5x100)
- Phillip's screwdriver (0x75; 2x125)
- Allen keys (3 - 6 mm)
- Torque wrench 1 to 5 Nm (R.304DA Facom) (Sames P/N: 240000095)
- Open-ended spanners (5 - 5.5 - 15 - 17 - 18 - 21 - 24 - 27 mm)
- Socket wrench (socket diameters 4)
- Flat nose pliers
- Cutting pliers

## 5.2. Using the multipurpose spanner

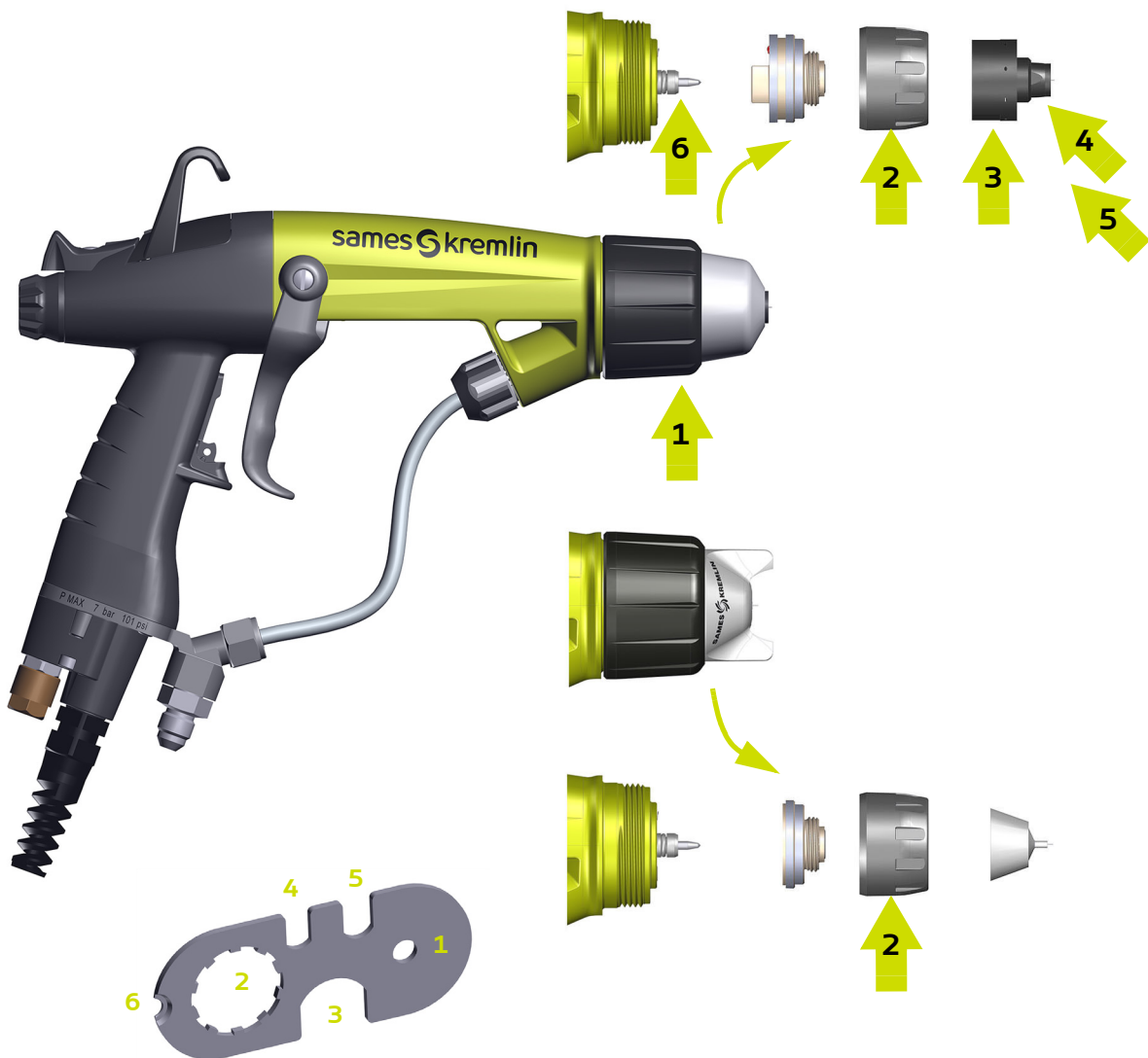

- 1 : Tighten the air cap ring.
- 2 : Tighten the ring of the nozzle support.
- 3 : Tighten the fitted low pressure nozzle assembly (round spray).
- 4 : Tighten the injector (Dia.: 6 and 8 mm) onto the air cap (round spray).
- 5 : Tighten the injector (Dia 12 mm) onto the air cap (round spray).
- 6 : Remove the seal cartridge from the barrel.

### 5.3. Installation

#### 5.3.1. With piston pump for all versions



Before any work, please refer to the installation rules ([see § 1.7 page 11](#)).

1	General air supply
2	Air filter
3	Main air valve
4	Pump air shut-off valve
5	Air pressure regulator
6	Spraying air filter/regulator
7	Spraying air valve
8	GNM 6080 control module
9	Spray gun air supply hose
10	Nanogun+ Airspray Spray Gun
11	Low voltage power supply cable
12	Pump (complies with ATEX Directive)
13	Dump valve
14	Product filter
15	Product supply hose
16	Mains power cable (220V + ground) or (115V + ground)
17	Warning sign
18	Potentially explosive atmosphere
19	Area with no risk of explosion

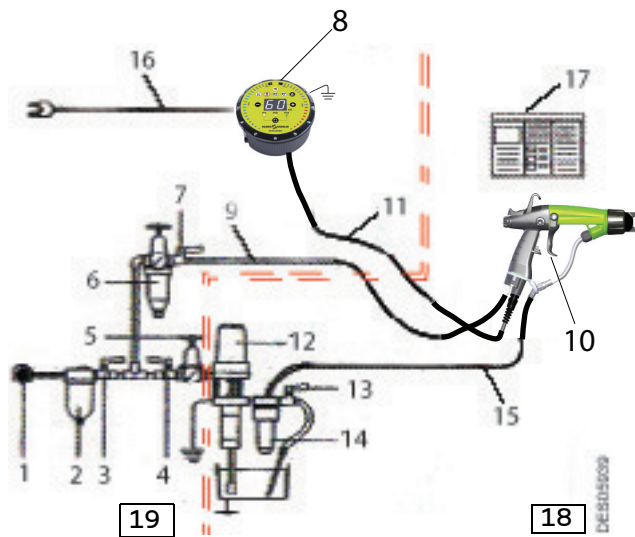

The paint supply must be installed in a well-ventilated area.

The paint container and pump must always be electrically grounded.

The dump hose must be submerged in the paint.



**The paint supply pump:**

- must have a maximum ratio of 1:1.
- and the pump air supply must be fitted with a safety valve limiting pressure to 6.5 bar max.

5.3.2. With diaphragm pump for all versions

1	Part to be painted
2	Nanogun+ Airspray Spray Gun
3	Single-phase mains, 220 V, 50 Hz + ground or 115 V+ ground
4	Air pressure regulator 0-6 bar - 50 m <sup>3</sup> /h (for adjusting the spraying air)
5	Compressed air network
6	Stop cocks
7	Oil-removing filter
9	Air pressure regulator 0-6 bar - 5 m <sup>3</sup> /h For adjusting the regulator control pressure (paint flow rate setting)
10	Air pressure regulator 0-6 bar - 20 m <sup>3</sup> /h (for adjusting the pump air supply)
12	Potentially explosive atmosphere
13	Area with no risk of explosion
14	Paint flow rate regulator
15	Diaphragm pump (complies with ATEX Directive)
16	Strainer
17	Paint container

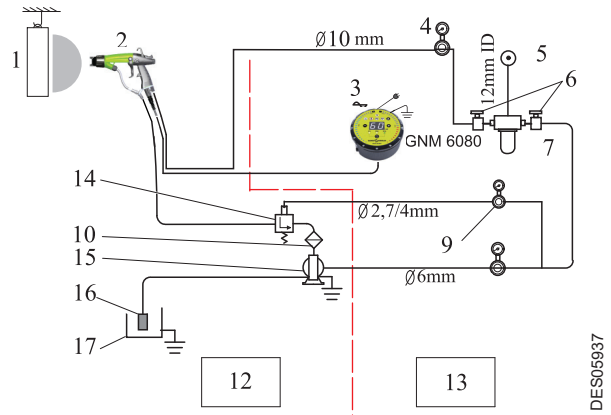

**Note:** m<sup>3</sup>/h volume at 1013 mbar atmospheric pressure and a temperature of 20°C (68°F).  
It is recommended to fit the diaphragm pump with a valve on the return line to the paint container to prime the pump and stir the paint.



For the safety of the painter, the paint container, the diaphragm pump, and the paint filter, if it is metal, must be electrically grounded.

5.3.3. With a pressure tank for all versions

1	Part to be painted
2	Nanogun+ Airspray Spray Gun
3	Single-phase mains, 220 V, 50 Hz + ground or 115 V + ground
4	Air pressure regulator 0-6 bar - 50 m <sup>3</sup> /h (for adjusting the spraying air)
5	Compressed air network
6	Stop cocks
7	Oil-removing filter
9	Air pressure regulator 0-6 bar - 5 m <sup>3</sup> /h For adjusting the regulator control pressure (paint flow rate setting)
10	Filter
11	Pressure tank (complies with ATEX Directive)
12	Potentially explosive atmosphere
13	Area with no risk of explosion

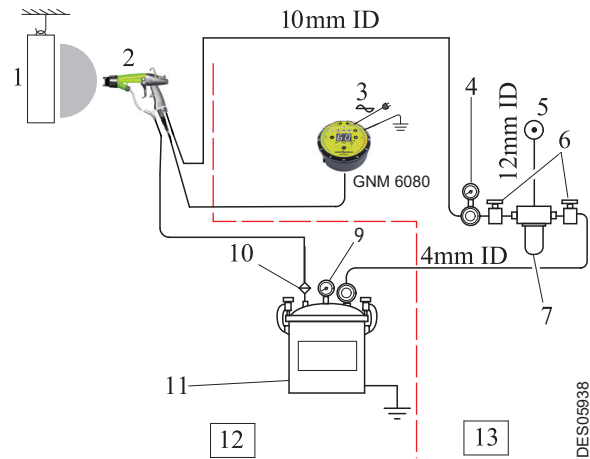

**Note:** m<sup>3</sup>/h volume at 1013 mbar atmospheric pressure and a temperature of 20°C (68°F).  
 You are advised to fit a pneumatic stirrer on the pressure tank to stir the paint.  
 A filter with a screen should be fitted at the spray gun paint hose inlet.



For the safety of the painter, the pressure tank and the paint filter, if it is metal, must always be electrically grounded.



## 6. Maintenance

Preventive maintenance is an essential part of production and ensures the reliability of the installation. As a reminder, the performance of equipment can only be guaranteed if a minimum of control and cleaning operations are performed on this equipment.



Soiling and wear of the Nanogun+ Airspray gun depend on the operating and application conditions and the production rates.

### 6.1. Summary table of maintenance operations

The maintenance intervals indicated in the procedures below are only indicative. The user will have to create his own maintenance schedule as he use Sames equipment.

Carry out when the maintenance indicator light of the GNM 6080 is ON.

Procedure		Detail	Duration	Frequency
<b>Cleaning</b>				
<b>A</b>	<b>A1</b>	Cleaning the product circuit	10 min	Once a day
	<b>A2</b>	Cleaning the spray gun	10 min	Once a day
	<b>A3</b>	Waste disposal	5 min	Once a day
	<b>A4</b>	Demolition and Recycling	5 min	Once a day
<b>Replacement</b>				
<b>Paint circuit</b>				
<b>B</b>	<b>B1</b>	Replacement of the paint hoses	10 min	2000 hours
	<b>B2</b>	Replacement of the spray head assembly	5 min	1000 hours
	<b>B3</b>	Replacement of the paint needle	5 min	2000 hours
<b>Barrel</b>				
<b>C</b>	<b>C1</b>	Replacement of O-rings and seals	10 min	2000 hours
	<b>C2</b>	Replacement of the air valve	5 min	2000 hours
	<b>C3</b>	Replacement of the high voltage cascade	20 min	-
<b>Handle</b>				
<b>D</b>	<b>D1</b>	Replacement of the handle	20 min	2000 hours
	<b>D2</b>	Replacement of the electropneumatic coupling	5 min	4000 hours
	<b>D3</b>	Replacement of the switch	20 min	4000 hours
	<b>D4</b>	Replacement of the trigger	5 min	1000 hours
	<b>D5</b>	Replacement of the fixing hook	5 min	4000 hours

## 6.2. Preventive maintenance plan – PMP 7105

[see § 11.1 page 77](#)

The objective of the proposed preventive maintenance plan is to define in an exhaustive way, the verification, replacement and cleaning actions of the installed Sames equipment.

In order to anticipate breakdowns and malfunctions that may be due to technical deviations of the installation, the preventive maintenance plan attached to the user manual lists the routine maintenance operations necessary for better comfort in the use of the production tool.

Depending on the skills, area of responsibility and accreditation of each person involved, the preventive maintenance plan can be divided into two distinct levels: level 1 and level 2:

- **Level 1:** first level maintenance is essentially composed of visual control and cleaning operations of some elements of the equipment. To limit this level, only the specific tools supplied with the equipment will be used. This first level of maintenance is generally taken care of by paint operators or installation managers.
- **Level 2:** second level maintenance completes the first level by more complex dismantling operations requiring electrical engineering tools.  
This second level is generally handled by the factory maintenance department.

## 6.3. Cleaning

**Always refer to the health and safety instructions before carrying out any work on the spray gun** ([see § 1 page 6](#)).



**Always wear safety glasses.**  
**When handling solvents, wear gloves of a suitable resistant material.**  
**Work in a well ventilated area when using solvents.**



**Before any maintenance work on the spray gun, always refer to the health and safety instructions** ([see § 1 page 6](#)):

- Disconnect the control module from the power supply.
- Check that the air and paint circuits are not pressurised.
- Dump the paint circuit.

### 6.3.1. Procedure A1 : Cleaning the product circuit

- Disconnect the GNM 6080 control module.
- Install a bucket of solvent in place of the paint container.
- Open the recirculation valve to clean the pump.
- Close the recirculation valve and hold down the trigger until clean solvent comes out of the spray gun nozzle/tip.

### 6.3.2. Procedure A2 : Cleaning the spray gun

The spray gun must be cleaned immediately after use and at the end of the day, as with all paint guns. The cleaning procedure described below should be followed carefully:



It is formally forbidden to plunge the **Nanogun+ Airspray** into solvent.

Use a suitable solvent: non-greasy, high resistivity, non-chlorinated solvent.

- Step 1:** Disconnect the GNM 6080 control module.
- Step 2:** Depressurise the spray gun air circuit.
- Step 3:** Dump the spray gun paint circuit and rinse with an appropriate solvent ([see § 1.9 page 14](#)).
- Step 4:** Depressurise the spray gun paint circuit.
- Step 5:** Dry the spray gun air cap with a soft, dry, lint-free cloth.
- Step 6:** Unscrew the spray gun air cap ring and remove the air cap ([see § 8.7 page 65](#)).
- Step 7:** Clean the air cap with a solvent-dampened brush and then wipe dry.
- Step 8:** Reassemble the air cap and ring.
- Step 9:** Dry the compressed air spray gun (facing downwards) before restarting the GNM 6080 control module.



**Never disassemble the needle assembly when the paint hose contains paint or solvent.**



**When cleaning the nozzle/tip, always point the spray nozzle/tip towards the ground to prevent solvent or paint from flowing into the barrel ducts.**



**After cleaning, the ducts and supply hose must be dried with compressed air to remove all traces of solvent.**

### 6.3.3. Procedure A3: Waste disposal

Waste generated by use of the apparatus (spent solvent, unused paint, residue, dirty cloths, paint booth slurry, water-wash spray booth run-off, used dry filters, ventilation air etc.) must be removed, transported and disposed of in strict compliance with the applicable local regulations.

6.3.4. Procedure A4: Demolition and Recycling

6.3.4.1. Nanogun+ Airspray



All the parts can be contaminated by paint residues and/or of solvent. Before proceeding to the demolition of the equipment, clean the spray gun and more particularly the inside of paint hoses with an appropriate cleaning product and air-drying them with compressed air.

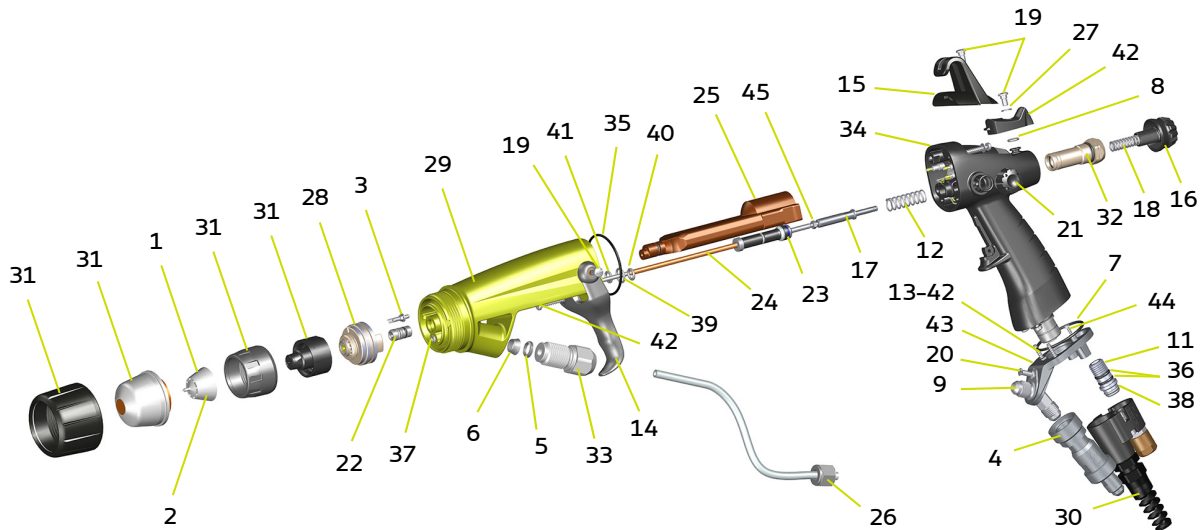

Item	Material
<b>Spraying area</b>	
1,6, 22,28,33,37	Plastics charged glass fiber or kevlar
31	Plastic charged PTFE or chemically inert rubber
28	Plastics charged with fibers, titanium
2	Plastics and stainless steel
5, 22	Chemically inert rubber
3*	Brass
26	Polyethylene and stainless steel
<b>Barrel area</b>	
14, 29*	Plastic charged glass fiber
8, 19	Stainless steel
35, 39,40, 41, 42	Chemically inert rubber or fiber O-rings
25	Plastic, copper, steel, ceramic, electronic and electric components ROHs
<b>Air and product valve area</b>	
23, 24*	Tungsten, PEEK, stainless steel, chemically inert rubber, PTFE, magnet (iron), aluminium
12*, 18*, 45*	Stainless steel
16*, 17*, 21	Aluminium
32	Plastics, chemically inert rubber
<b>Handle area</b>	
15, 34	Plastics charged glass fiber, stainless steel, brass, copper
Not shown	Sensor position trigger: electric components ROHs, plastic, copper
	connector at the bottom of the handle: ROHs electronic components, plastic, copper

19	Stainless steel
27	Plastic charged glass fiber, magnet (iron)
<b>Area base plate of handle connection towards the control module</b>	
13	Aluminium
11, 20, 42, 43, 44	Stainless steel
7, 36	Rubber
30	Plastics charged glass fiber, stainless steel, copper
<b>Product /air hose area</b>	
Not shown	Air hose: PU
Not shown	Product hose: polyethylene or elastomerized polyethylene Connections: zinc coated steel and stainless steel Sheath: polyamide Stuffing box: plastic charged Fitting: zinc coated steel and stainless steel

**\* These components (3, 12, 16, 17, 18, 24, 29, 45) can be soiled with dielectric grease.**

6.3.4.2. GNM 6080

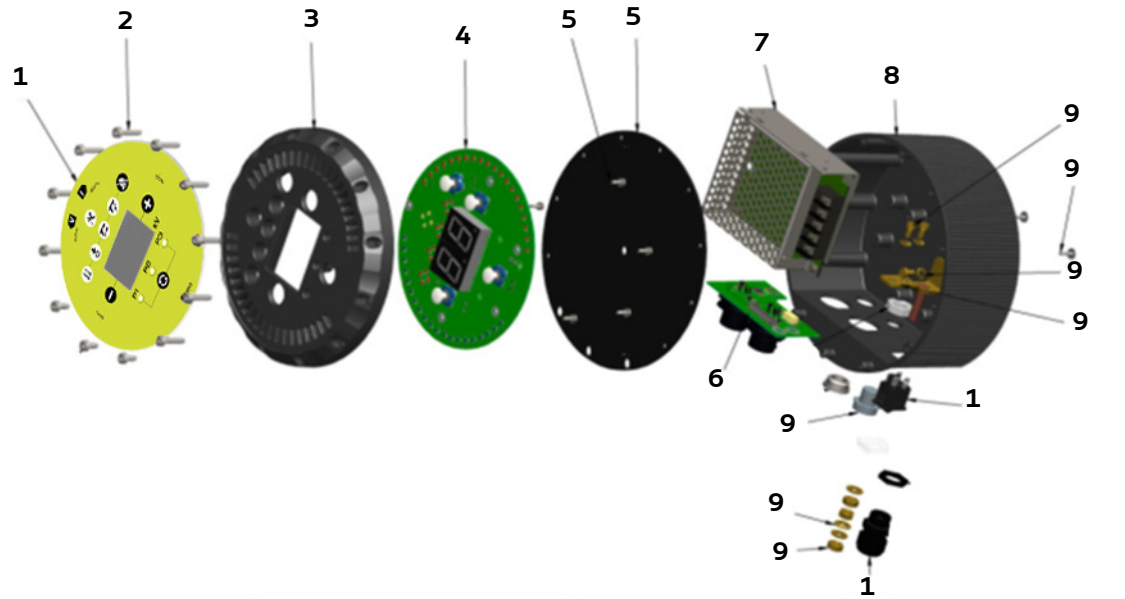

Item	Description	Material
1	Keyboard / front face*	Plastic
2	Fastening screw of front face	Stainless steel
3	Support of main board and front face	Aluminium
4	Main board	Electric and electronic components, printed circuit ROHs
5	Rear metal sheet and fastening screw	Steel
6	Connector board	Electric and electronic components, printed circuit ROHs
7	Electric power	Electric and electronic components, printed circuit ROHs
8	Box	Aluminium
9	Fixation accessories	Steel and brass
10	Electric switch	Electric component ROHs
11	Stuffing box	Plastic
Not shown		
12	Power cable	Plastic and copper

**\* Attention, this component can be soiled with dielectric grease.**

## 6.4. Replacement

### 6.4.1. Procedure B1: Replacement of the paint hoses

#### 6.4.1.1. Paint hose - QD version (HR)

- **Step 1:** Side handle, unscrew the fitting using a 15mm open-ended spanner.

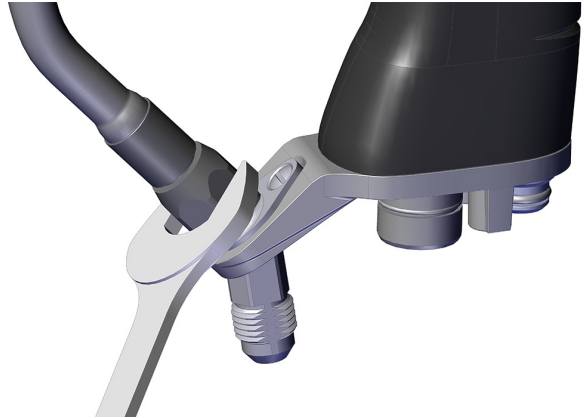

- **Step 2:** Release the paint hose from base.

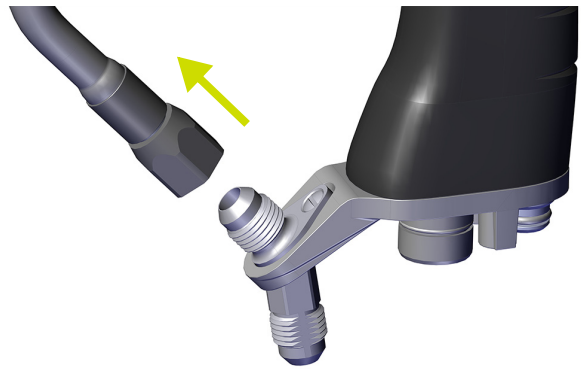

- **Step 3:** Using a 21 mm open-ended spanner, unscrew the upper nut of the paint hose, then stop loosening manually by maintaining the nut of bottom.

- **Step 4:** Check that the seal of the paint nut is in place. Check that the two olives (P/N 910018200) are installed on the paint hose (they can be lost in the event of leakage caused by inadequate tightening). In case olives must be removed, replace them necessarily by news.



**To reassemble,** follow the steps in reverse order. Tighten manually the upper paint hose nut until it levels the reinforcement of the barrel.

### 6.4.1.2. Paint hose LR-MR

- **Step 1:** Side handle, unscrew the paint hose nut with a 15 mm open-ended spanner.

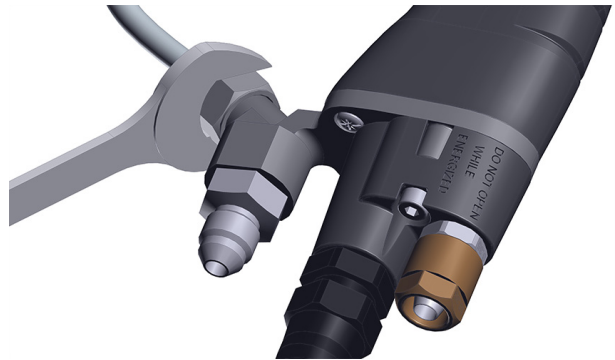

- **Step 2:** Using a 21mm open-ended spanner, loosen the upper paint hose nut. Unscrew the nut, whilst rotating the hose.



**To reassemble, follow the steps in reverse order.**



### 6.4.2. Procedure B2: Replacement of the spray head assembly Round Spray and Flat spray nozzles

- **Step 1:** Unscrew the air cap ring (A) by hand, then remove the air cap (B).

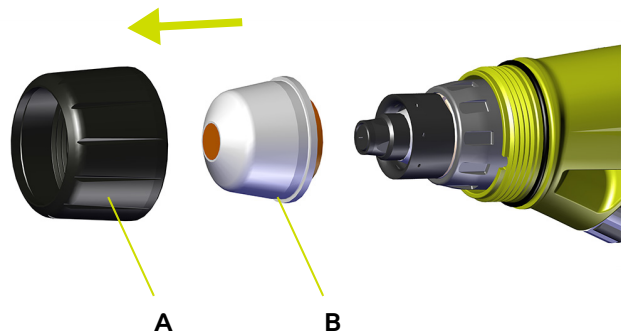

- **Step 2:** Unscrew the nozzle assembly and the nozzle support nut using the multipurpose spanner.
- **Step 3:** Remove the nozzle support, pulling it in a direction parallel to the barrel axis. Replace the seal every three months ([see § 8.8 page 65](#)).

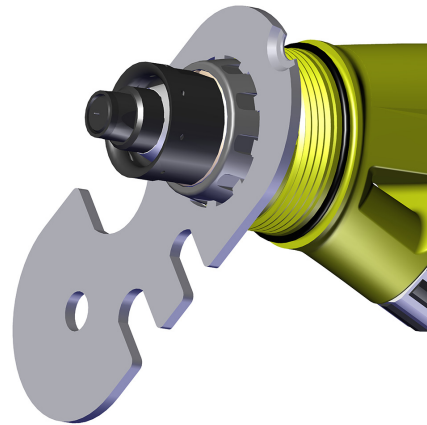

**To reassemble, follow the steps in reverse order.**

### 6.4.3. Procedure B3: Replacement of the paint needle

- **Step 1:** Unscrew the notched button (A) at the rear of the spray gun, retrieve the spring (B).

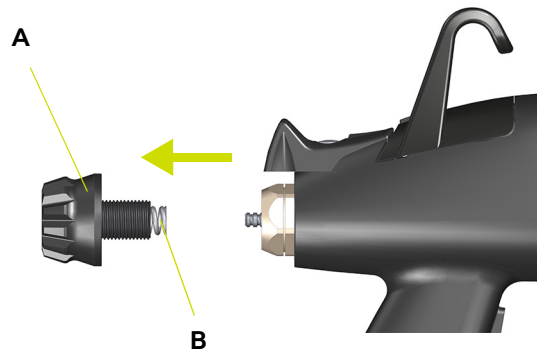

- **Step 2:** Press the trigger and pull manually the paint needle towards the back.

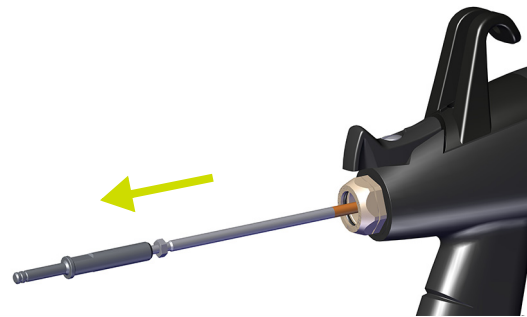

To reassemble, follow the steps in reverse order.



Every 4 or 5 reassemblies, add some dielectric grease (P/N# H1GSYN037) in the passage channel in the barrel.

### 6.4.3.1. Setting the paint needle

- **Step 1:** Remove electro-pneumatic coupling and product hose to the gun base.

- **Step 2:** Remove rear nut with paint spring

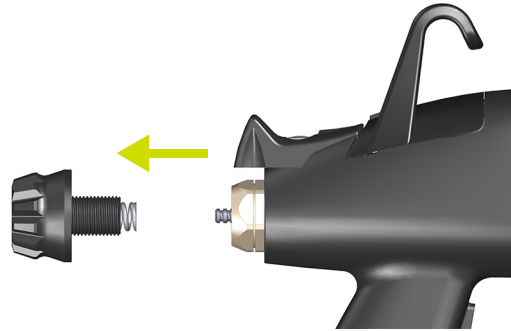

- **Step 3:** To ensure the needle is in contact with the seat nozzle (rest position), push it with your finger.

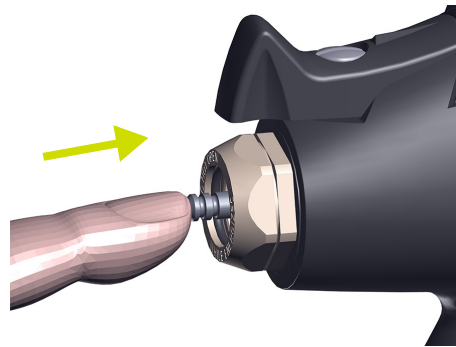

- **Step 4:** Considering that the needle is in contact with the seat nozzle, the length which is sticking out the rear nut should be used as initial position with a caliper (set at "000").

- **Step 5:** Press the trigger to extreme position in order to push back the needle to max rear position. Keep this position to measure needle's stroke.

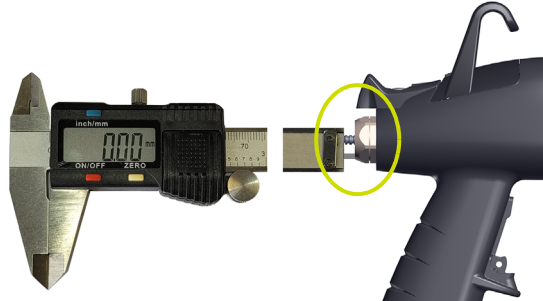

- **Step 6:** The value must be between 1.8 mm and 2.2 mm. If the value is not between the acceptable range, go to step 7. If the value is between the acceptable range, go directly to step 8.



- **Step 7:** Pull the needle out of the gun to adjust its length.

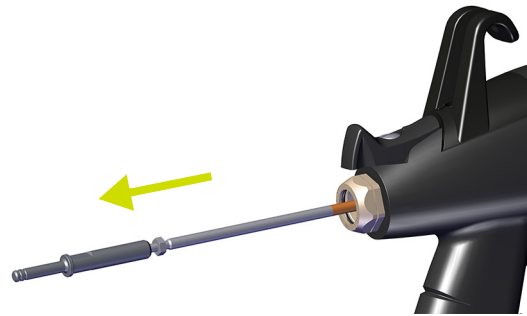

Untighten the nut «B» to allow the adjustment procedure.

- If the value on step 6 is under 1.8 mm, untighten the needle rear stop (A) to increase the needle length.

For information: One turn = 0.5 mm.

Tighten again the nut (B) to lock the needle length and check again the value according to step 6.

- If the value on step 6 is over 2.2 mm, tighten the needle rear stop (A) to reduce the needle length.

For information: One turn = 0.5 mm.

Tighten again the nut (B) to lock the needle length and check again the value according to step 6.

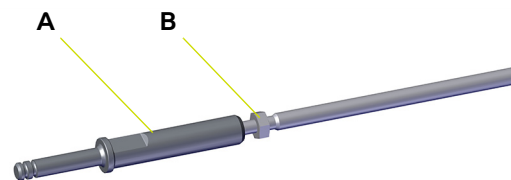

- **Step 8:** Re-install the rear nut living 2 mm to 2.5 mm gap.

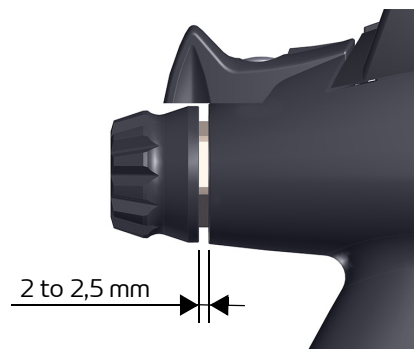

#### 6.4.4. Procedure C1: Replacement of O-rings and seals

Replacing the seals on the spray head side

- **Step 1:** Seal cartridge: Extract the cartridge from the barrel using the multipurpose spanner. The cartridge should be replaced every time it is disassembled.

If the o-ring at the front of the cartridge is to be replaced, removed it with a screwdriver, insert the new o-ring, ensuring it is positioned correctly.

When reassembling, ensure the cartridge is inserted in the correct orientation (white seal facing outwards). Push the cartridge until it clips into the barrel. Coat the white seal and the anti-extrusion ring with a fine layer of vaseline.

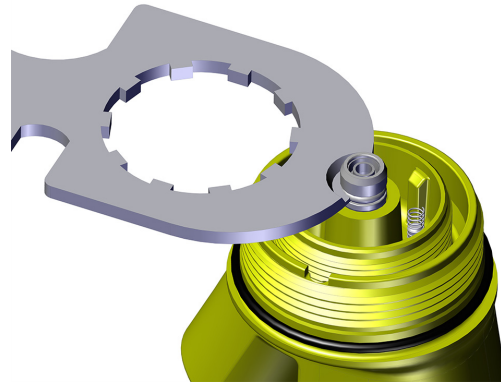

- **Step 2:** Seal: Replace the seal every three months. Remove the seal using a 2.5mm screwdriver, taking care to avoid damaging the barrel.



- **Step 3:** HV contact: Unscrew the HV contact using a 4mm socket wrench. The fibre washer should always be replaced whenever the device is disassembled. Replace the HV contact if necessary, then screw back into the barrel.

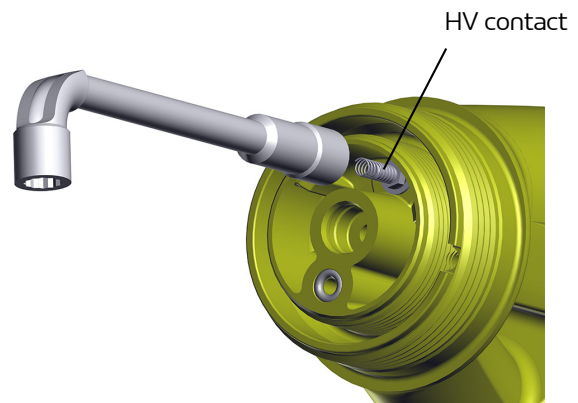

Replacement of the seals on the handle side

- **Step 1:** Remove the trigger [see § 6.4.10 page 52](#), and the paint needle.
- **Step 2:** Unscrew the four screws fastening the barrel on the handle.
- **Step 3:** Unscrew manually or with a small flat pliers the three connection wires of the high voltage unit, pull carefully the contacts towards the back.
- **Step 4:** Replace the o-rings (B) of the air ducts and the air valve (Step 3: not obligatory): Remove and replace the three o-rings.

- **Step 5:** Replace the o-ring barrel/handle (A) (Step 3: obligatory): Remove and replace the o-ring. Replace this o-ring every year.

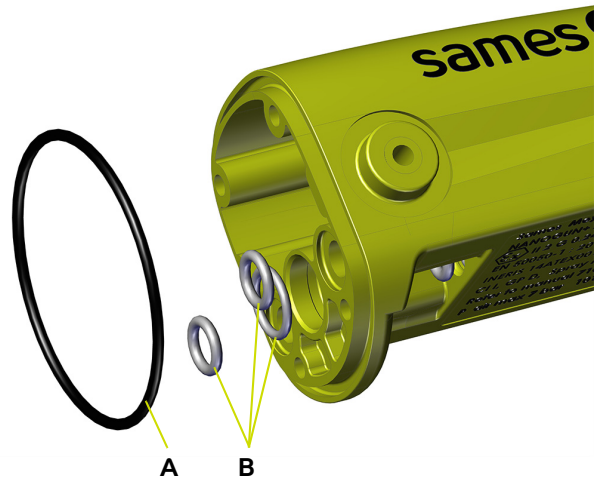

- **Step 6:** Replace the o-ring back of paint needle (C). Remove and replace the o-ring.

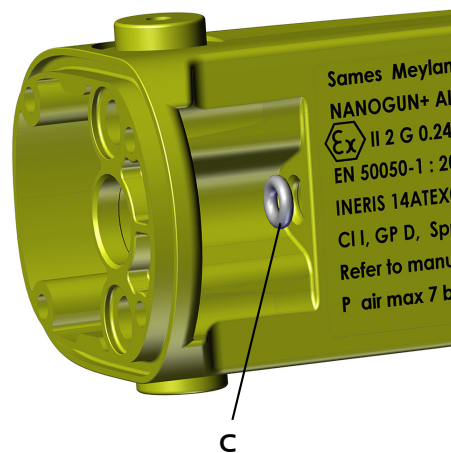

To reassemble, follow the steps in reverse order.

### 6.4.5. Procedure C2: Replacement of the air valve

- **Step 1:** Remove the paint needle ([see § 6.4.3 page 42](#)).
- **Step 2:** Unscrew the air valve stop nut using a 18 mm open-ended spanner.

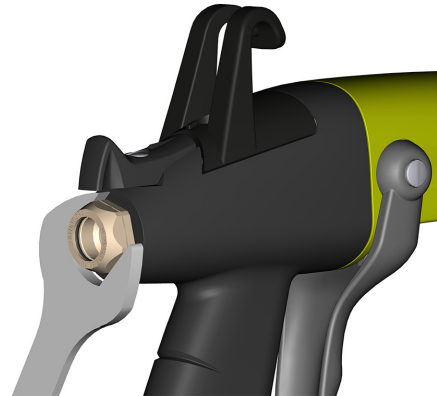

Position the gun barrel to the top and recover the spring and the air valve. If the parts do not fall, tap in the palm of the hand.



or use the paint needle to extract the air valve.

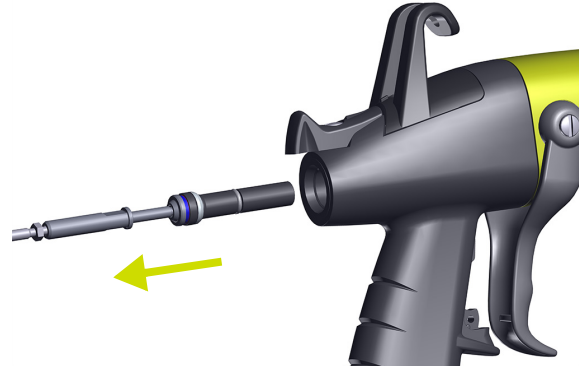

**WARNING :** It is important to retrieve the shoulder washer (A) when removing the paint pin so that it does not get lost. When reassembling, it is imperative to observe the mounting direction of the shoulder washer (A) as shown in the illustration.

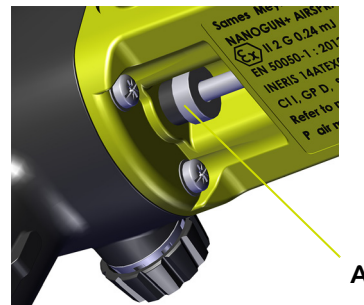

### 6.4.5.1. Repairing the air valve

Three levels of maintenance are possible:

- **Level 1:** Standard level of maintenance because the body of the air valve does not undergo any friction nor wear.
- **Level 2:** Corrective maintenance, carry out if the valve body is damaged.
- **Level 3:** Exceptional maintenance, carry out if the magnet is lost or broken.

**Level 1:** Replacement of the three o-rings (P/N J3STKL032 inner ring, J3STKL005 outer ring and 900010256 conical seal).

- For three seals, extract the old by taking care of not damaging the body of the air valve (but they can be destroyed).
- The conical seal must be pushed up to its click-and-ratchet work on the body of the air valve by taking care not to damage its conical reach.

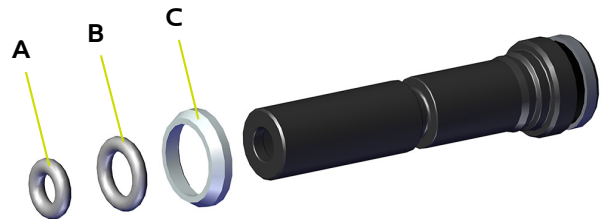

**Level 2:** If the valve body is damaged.

- Extract manually the aluminium ring or put a M4 screw in the ring, pull out in the axle of the part, and remove the magnet by taking care to locate its direction (silver face on the ring side).
- Put in place the magnet in the right direction and retain the ring in the body of the air valve by pushing firmly with the finger.

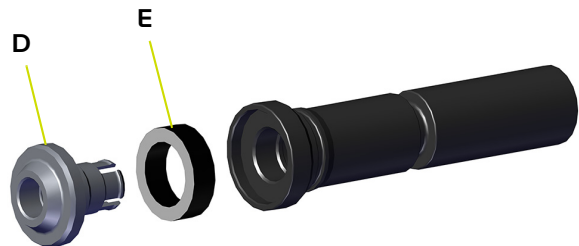

After complete reassembly of the spray gun, check the activation and the stop of the high voltage. If the high voltage is permanently engaged or does not cut itself: check the direction of the magnet.

**Level 3:** If the magnet is broken or lost.



**For this maintenance operation, it is recommended to contact Sames.**



### 6.4.6. Procedure C3: Replacement of the high voltage cascade

- **Step 1:** First, remove the trigger ([see § 6.4.10 page 52](#)), remove the paint needle ([see § 6.4.3 page 42](#)) and the fixing hook ([see § 6.4.11 page 53](#)).

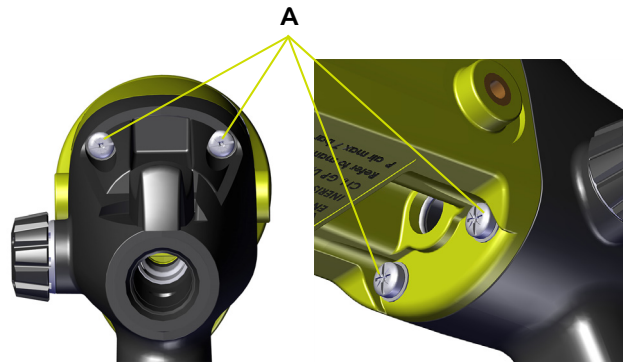

- **Step 2:** Loosen the 4 screws (A) fastening the barrel on the handle with a 2mm Phillips screwdriver.

- **Step 3:** Unscrew, manually or with a small flat pliers, the three connection (B) wires of the high voltage unit, pull carefully the contacts towards the back.

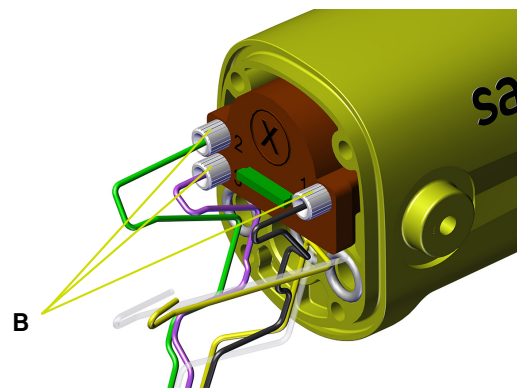

- **Step 4:** Remove the high voltage contact in front of the barrel ([see § 6.4.4 page 45](#)). Withdraw the high voltage unit.

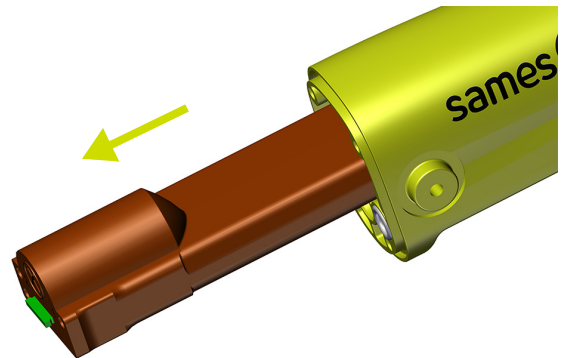

**WARNING:** Attention with the colors (terminal 1: black, terminal 2: green, terminal 3: pink).

To reassemble, follow the steps in reverse order. Replace the high-voltage cascade. Coat the cascade with dielectric grease (P/N # H1GSYN037) then insert it into its housing. Push the cascade fully into the barrel. Connect the three wires and tighten the screws. Check the wear of the o-rings, replace if necessary.

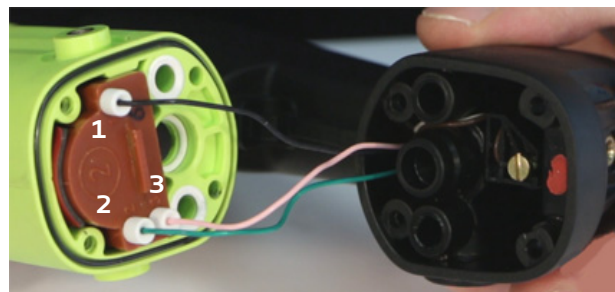

### 6.4.7. Procedure D1: Replacement of the electropneumatic coupling

- **Step 1:** Separate the barrel from the handle.
- **Step 2:** Handle base  
Unscrew the air nipple using a 6mm allen key.  
Replace the seals every 12 months.

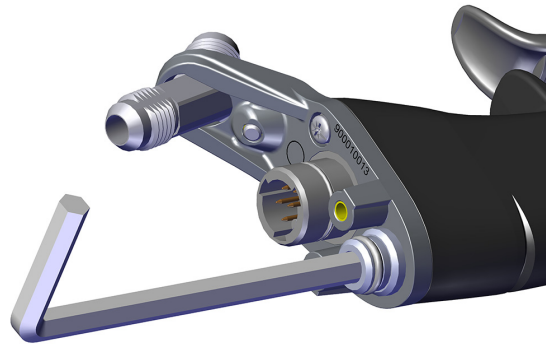

- **Step 3:** Undo both K35 x 14 screws with a 2mm Phillip's screwdriver. Change the fibre washers each time the screws are removed.

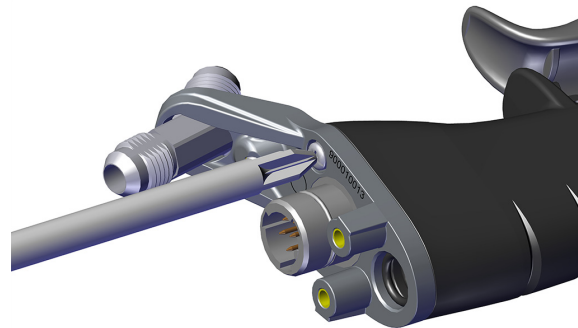

- **Step 4:** Lift the base to access the handle base seal. This seal should be replaced every 12 months.

- **Step 5:** Push the electrical connector to release it and remove from the base.  
Replace the seal of the connector every 12 months.

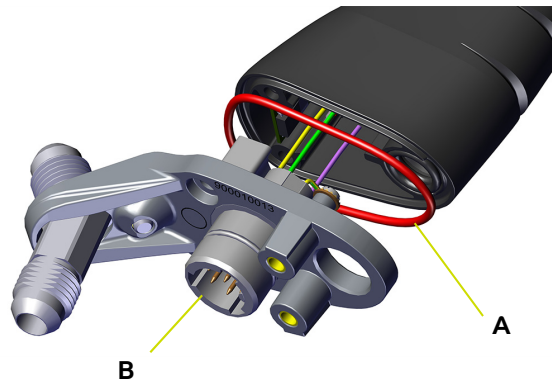

- **Step 6:** Replacement of the base: unscrew the screw of the ground wire using a 0 Phillip's screwdriver, withdraw it and replace it.

To reassemble, follow the steps in reverse order.  
Insert the connector pin back into the base foolproofing slot.  
Coat the air nipple seals with dielectric lubricant.  
Tighten the air nipple to 1.5 N.m torque.  
Tighten the two K35 x 14 screws to 1.3 N.m torque.

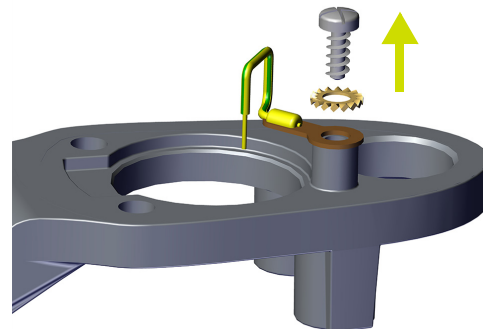

6.4.8. Procedure D2: Remove paint hose. Loosen the paint hose nut with a 15mm open-ended spanner.

- **Step 1:** Remove paint hose. Loosen the paint hose nut with a 15mm open-ended spanner.

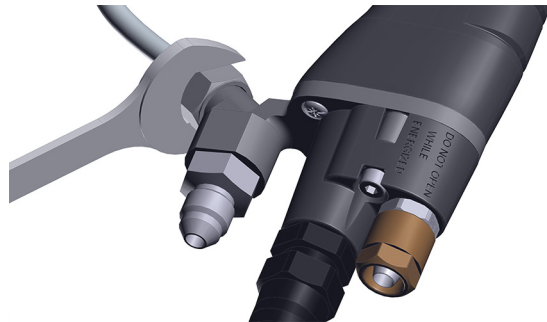

- **Step 2:** Unscrew the two captive screws from the electropneumatic coupling with a 3mm allen key.

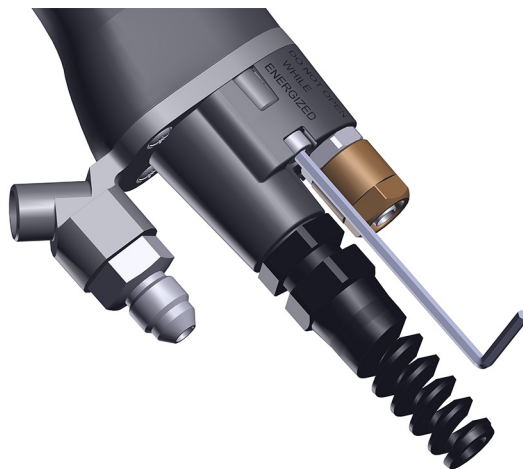

- **Step 3:** Pull the electropneumatic coupling apart to disconnect.

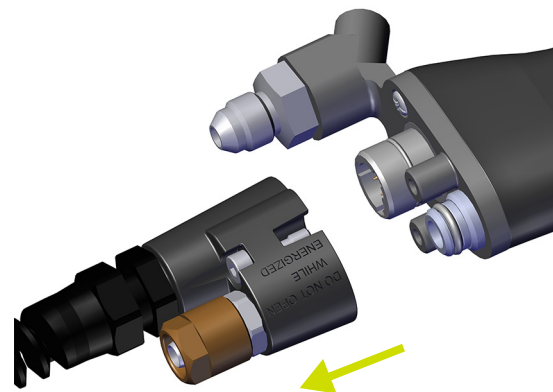

**Do not remove the cable gland from the electrical cable.**

#### 6.4.9. Procedure D3: Replacement of the switch

- **Step 1:** With a 5,5 mm screwdriver, unscrew the shouldered screw. Pull upwards the lever of the switch.
- **Step 2:** Replace the o-ring ([see § 8.4 page 61](#)) Insert the new switch into its housing. Coat with low threadlocker the fastening screw and tighten the screw so that the switch is slightly resistant.



#### 6.4.10. Procedure D4: Replacement of the trigger

- Using a screwdriver, unscrew both shouldered screws and release both sides of the trigger.

#### Reassembling the trigger:

- Put in place one on the sides of the trigger on its shoulder then slide the other side into its housing.

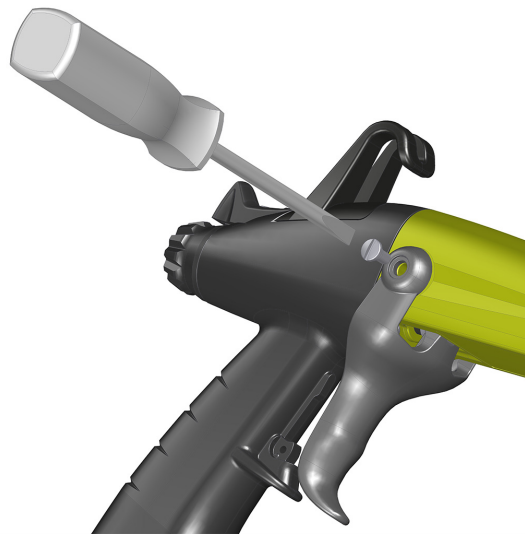

### 6.4.11. Procedure D5: Replacement of the fixing hook

- **Step 1:** Put the switch (A) in position «I».
- **Step 2:** With a 5.5mm screwdriver, unscrew the shouldered screw

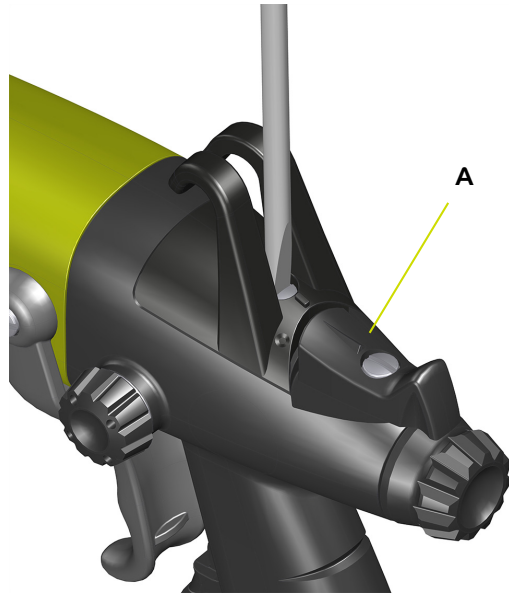

- **Step 3:** Remove the hook by pulling upwards.

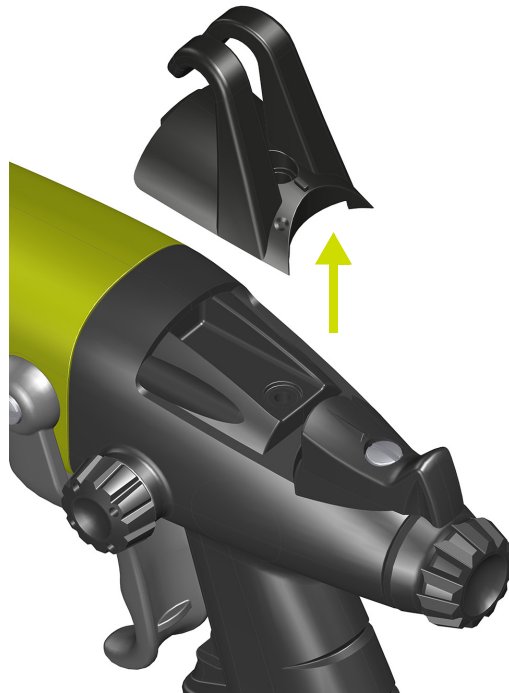

## 7. Troubleshooting Guide

Faults	Possible causes	Remedies
Irregular paint spray	Air in paint circuit	Dump the paint circuit
	Paint flow too low	Increase pressure in pump or pressure tank
	Impurities in circuit	Check filter, then drain circuit
	Paint tank empty (or nearly)	Refill paint tank
	Paint viscosity too high	Check paint viscosity
Paint not fluid enough when leaving spray gun	Blocked nozzle/tip	Clean nozzle/tip
	Needle does not retract	Check needle assembly
	Clogged filter	Clean filter
	Insufficient pump pressure	Check pump
	Paint viscosity too high	Check paint viscosity
	Ø 6..35 mm paint hose clogged	Unblock or replace paint hose
Paint flows out continuously	Needle is obstructed and cannot close	Remove nozzle/tip holder and clean holder and seat. Clean needle tip
	Worn needle	Replace needle and, if necessary, the nozzle/tip holder
	Nozzle/tip holder damaged	Replace nozzle/tip holder
Paint comes out of air cap air holes	Nozzle/tip insufficiently tightened against seat	Tighten nozzle/tip
	Damaged cartridge	Replace cartridge
	Damaged paint seal	Replace seal
Poor spraying quality	Nozzle/tip partially blocked	Clean nozzle/tip
	Paint flow too weak	Increase paint flow
	Viscosity too high	Dilute paint
	Insufficient air for spraying	Increase air pressure
	Paint flow too high	Reduce paint flow
	Paint injector damaged	Replace the injector
Orange peel effect	Solvents evaporating too quickly	Use heavier solvents
	Paint droplets too large	Increase spraying distance
		Dilute paint
		Increase spraying air pressure
		Decrease nozzle/tip size
Increase the electrostatic effect		

Faults	Possible causes	Remedies
Paint running	Solvents evaporating too slowly	Use lighter solvents
	Spraying applied too slowly	Reduce paint flow
		Increase spraying air pressure
Paint spray overloaded in middle	Paint flow too high	Reduce the electrostatic effect
		Reduce paint flow
	Increase air pressure	
	Nozzle/tip too large	Use a smaller nozzle/tip
Insufficient electrostatic effect	Paint viscosity too great	Dilute paint
	Air holes partially blocked	Clean spray head
	High voltage power not on	See display on control module
		High voltage power insufficient
	Distance between spray head and part too great	Check <b>Nanogun+ Airspray</b> output voltage
		Spray from between 200 and 300 mm away
	Part not grounded	Clean hooks. Check grounding connection of parts conveyor
	Excessive ventilation	Reduce paint booth air extraction rate, ensuring the applicable regulations are still complied with
	Spraying air pressure too high	Reduce spraying air pressure
	Paint flow too high	Reduce paint flow
	Product resistivity too high	Reduce product resistivity to obtain $\rho < 500\text{M}\Omega\cdot\text{cm}$
	Control module short circuit: - external	Clean outside of the spray gun with a non-conductive solvent ( $\rho > 15\text{M}\Omega\cdot\text{cm}$ )
Use a new, clean and dry case		
Control module short circuit: - via needle assembly	Replace seal cartridge and needle	
Control module short circuit: - via air channels	Clean the air channels of the barrel	
Control module short circuit: - via product hose	Increase the resistivity of paint so that $\rho > 5\text{M}\Omega\cdot\text{cm}$	
Operator gets electric shocks when touching the part	Part not grounded or poorly grounded	

## 8. Spare Parts

The spare parts are classified in 2 different types:

- **1st emergency parts:**

The 1st emergency parts are strategic components which are not necessarily consumables but which in case of failure prohibit the operation of the equipment.

Depending on the production line's commitment and the production rates imposed, the first emergency parts are not necessarily kept available in the customer's stock.

Indeed, if an interruption of the production flow is possible, storage is not necessary.

On the other hand, if the stop is not possible, the 1st emergency parts will be kept in stock.

- **Wearing parts:**

Wearing parts are consumable components such as O-rings that undergo regular degradation over time during normal operation of the installation. It is therefore advisable to replace them according to a defined frequency and adapted to the operating time of the installation.

The wearing parts must therefore be kept in the customer's stock.



**To guarantee an optimal assembly, spare parts must be stored in a temperature close to their temperature of use. Should the opposite occur, a sufficient waiting time must be observed before the installation, so that all the elements are assembled in the same temperature.**



8.1. Nanogun+ Airspray spray guns low pressure for high resistivity (HR) solvent paint  $\rho > 10M\Omega.cm$

Round spray versions  
JR 06 / JR 08 / JR 12

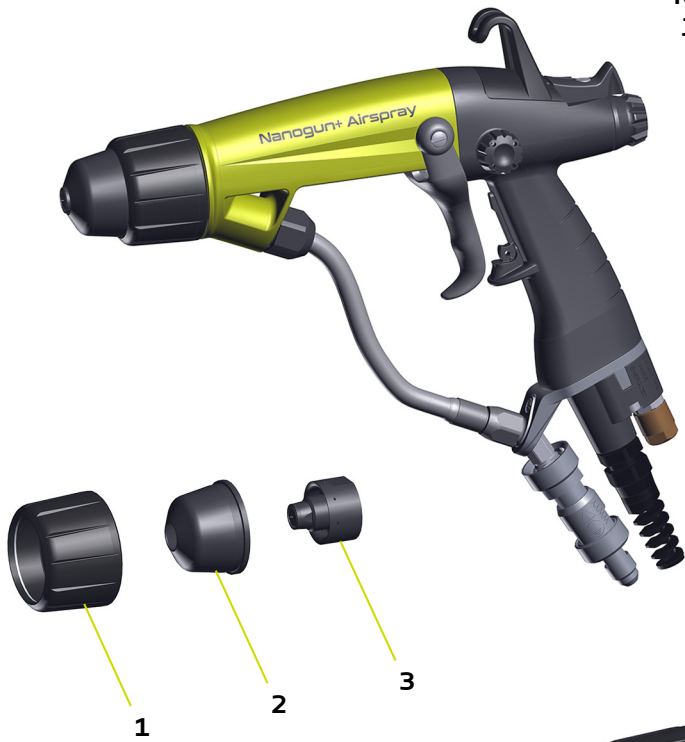

Flat spray version

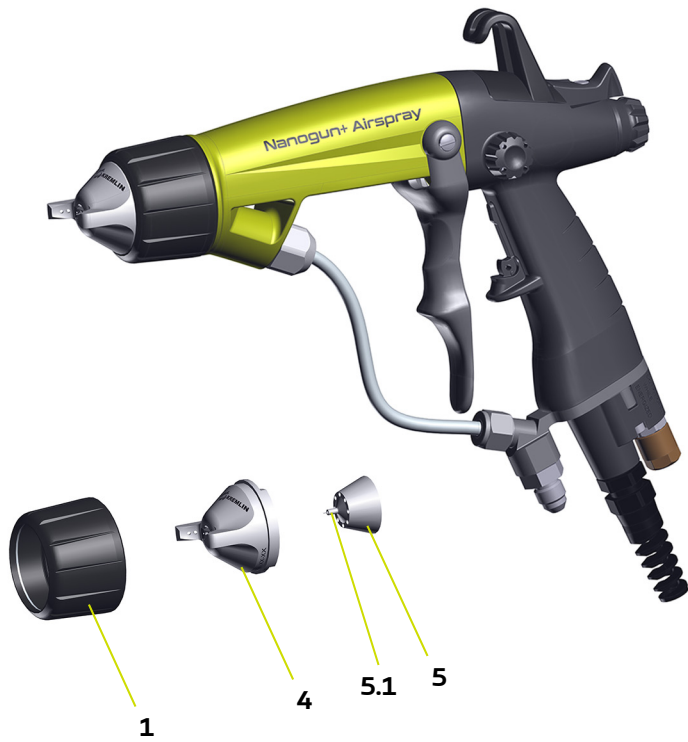

For the various options: [see § 8.15 page 71](#).

Item	Part number	Description	Qty	Unit of sale	Spare Part Level (*)
	910018773	Nanogun+ Airspray JR 06 LP HR round spray	1	1	-
	-	Nanogun+ Airspray spray gun ( <a href="#">see § 8.4 page 61</a> )	-	-	-
1	910015921	Air cap ring ( <a href="#">see § 8.7 page 65</a> )	1	1	1
2	900011365	Super vortex cap	1	1	1-2
3	910018322	JR06 Round spray nozzle ( <a href="#">see § 8.9 page 66</a> )	1	1	2
<b>Not shown</b>					
	050123306	M1/2 JIC adapter - F3/8NPS paint hose	1	1	-

Item	Part number	Description	Qty	Unit of sale	Spare Part Level (*)
	910016712	Nanogun+ Airspray JR 08 LP HR round spray	1	1	-
	-	Nanogun+ Airspray spray gun ( <a href="#">see § 8.4 page 61</a> )	-	-	-
1	910015921	Air cap ring ( <a href="#">see § 8.7 page 65</a> )	1	1	1
2	900010503	Super vortex cap	1	1	1-2
3	910003847	JR08 Round spray nozzle ( <a href="#">see § 8.9 page 66</a> )	1	1	1-2
<b>Not shown</b>					
	050123306	M1/2 JIC adapter - F3/8NPS paint hose	1	1	-

Item	Part number	Description	Qty	Unit of sale	Spare Part Level (*)
	910016711	Nanogun+ Airspray JR 12 LP HR round spray	1	1	-
	-	Nanogun+ Airspray spray gun ( <a href="#">see § 8.4 page 61</a> )	-	-	-
1	910015921	Air cap ring ( <a href="#">see § 8.7 page 65</a> )	1	1	1
2	900010504	Super vortex cap	1	1	1-2
3	910003920	JR12 Round spray nozzle ( <a href="#">see § 8.9 page 66</a> )	1	1	1-2
<b>Not shown</b>					
	050123306	M1/2 JIC adapter - F3/8NPS paint hose	1	1	-

Item	Part number	Description	Qty	Unit of sale	Spare Part Level (*)
	910016710	Nanogun+ Airspray JP LP HR Flat spray	1	1	-
	-	Nanogun+ Airspray spray gun ( <a href="#">see § 8.4 page 61</a> )	-	-	-
1	910015921	Air cap ring ( <a href="#">see § 8.7 page 65</a> )	1	1	1
4	900009014	High efficiency air cap	1	1	1-2
5	1406402	SP nozzle assembly	1	1	1-2
5.1	446028	Electrode (included in item 5)	1	5	1
<b>Not shown</b>					
	050123306	M1/2 JIC adapter - F3/8NPS paint hose	1	1	-

(\*)

Level 1: 1st emergency parts

Level 2: Wearing parts

## 8.2. Nanogun+ Airspray, low Pressure spray guns for solvent paint $0.5 \text{ M}\Omega.\text{cm} < \rho < 500 \text{ M}\Omega.\text{cm}$



Nanogun+ Airspray Low Pressure low resistivity spray guns include the same components, except the product hoses.

Part number	Description	Qty	Unit of sale
910018774-075	Nanogun+ Airspray JR 06 LP LR, hose length: 7.5 m	1	1
910018774-150	Nanogun+ Airspray JR 06 LP LR, hose length: 15 m	1	1
910017190-075	Nanogun+ Airspray JR 08 LP LR, hose length: 7,5 m	1	1
910017190-150	Nanogun+ Airspray JR 08 LP LR, hose length: 15 m	1	1
910017189-075	Nanogun+ Airspray JR 12 LP LR, hose length: 7,5 m	1	1
910017189-150	Nanogun+ Airspray JR 12 LP LR, hose length: 15 m	1	1
910017188-075	Nanogun+ Airspray JP LP LR, hose length: 7,5 m	1	1
910017188-150	Nanogun+ Airspray JP LP LR, hose length: 15 m	1	1

### 8.3. Nanogun+ Airspray, low Pressure spray guns for solvent paint $2 \text{ M}\Omega.\text{cm} < \rho < 500 \text{ M}\Omega.\text{cm}$



Nanogun+ Airspray Low Pressure middle resistivity spray guns include the same components, except the product hoses.

Part number	Description	Qty	Unit of sale
910025604-075	Nanogun+ Airspray JR 08 LP MR, hose length: 7.5 m	1	1
910025604-150	Nanogun+ Airspray JR 08 LP MR, hose length: 15 m	1	1
910025605-075	Nanogun+ Airspray JR 12 LP MR, hose length: 7.5 m	1	1
910025605-150	Nanogun+ Airspray JR 12 LP MR, hose length: 15 m	1	1
910025606-075	Nanogun+ Airspray JP LP MR, hose length: 7.5 m	1	1
910025606-150	Nanogun+ Airspray JP LP MR, hose length: 15 m	1	1

**Flow limitation:**

The use of a whip limits the maximum flow very little once the extension hose has an inside diameter of 9.5 mm (3/8) as recommended.

The use of an extension of 6.3 mm inside diameter (1/4) is not recommended because it divides the maximum possible flow rate by 2 for low viscosities (20s) and by 3 for higher viscosities (50s).

**Resistivity limitation:**

Using a whip limits the low resistivity value to  $2 \text{ M}\Omega.\text{cm}$  (0.5 for the standard version). However if the application requires an electrostatic voltage lower or equal to 45kV, the minimum resistivity of the product can be  $1 \text{ M}\Omega.\text{cm}$ .

### 8.4. Nanogun+ Airspray spray guns, all versions

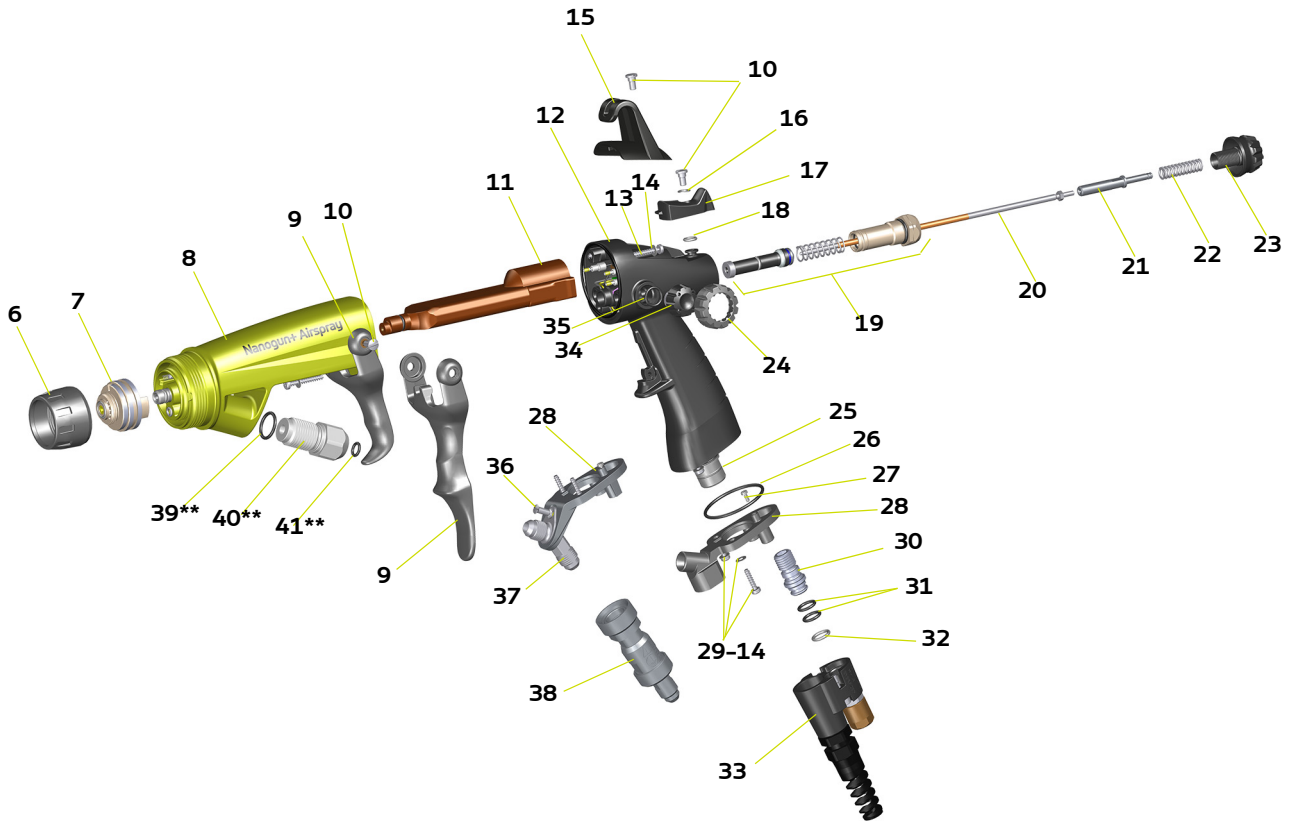

Item	Part number	Description	Qty	Unit of sale	Spare Part Level (*)
	-	<b>Nanogun+ Airspray spray gun</b>	-	-	-
6	900000320	Nozzle nut	1	1	1
7	<b>910015721</b>	<b>Nozzle support</b> ( <a href="#">see § 8.8 page 65</a> )	<b>1</b>	<b>1</b>	<b>1-2</b>
8	<b>910018202</b>	<b>Equipped barrel</b> ( <a href="#">see § 8.5 page 63</a> )	1	1	-
9	900010237	Trigger	1	1	-
	<b>910030837</b>	<b>4-finger trigger kit</b>	option	<b>1</b>	-
10	900010385	Shouldered C M4 screw	4	1	-
11	<b>910015508</b>	<b>High voltage unit</b>	<b>1</b>	<b>1</b>	<b>1</b>
	J2FTDF082	O-ring	1	1	-
12	<b>910015944</b>	<b>Nanogun+ Airspray equipped handle</b>	<b>1</b>	<b>1</b>	-
13	250000036	Screw securing handle/barrel	4	1	-
14	J4BRND039	Fibre seal for securing screw	6	1	-
15	900010239	Fixing hook	1	1	-
16	900013808	PTFE flat washer (included in item12)	1	1	-
17	<b>910018204</b>	<b>ON/OFF button with magnet and o-ring</b> (included in item 12)	<b>1</b>	<b>1</b>	-
18	J3STKL005	Chemically inert o-ring (included in item 17)	1	1	-
19	-	<b>Air valve and air valve nut</b> ( <a href="#">see § 8.6 page 64</a> )	<b>1</b>	-	-
20	<b>910018219</b>	<b>Needle</b> ( <a href="#">see § 8.10 page 67</a> )	<b>1</b>	<b>1</b>	<b>1-2</b>
21	900010253	Needle rear stop	1	1	-
22	900010265	8 bar paint spring	1	1	-
23	900010240	Paint flow button	1	1	-
24	900020056	Lateral tape adapter	option	1	-
25	160000041	O-ring chemically inert (included in item 7)	1	1	2
26	160000067	O-ring FKM red (included in item 7)	1	1	2
27	X3GJCP004	Zinc coated PT K25x6 screw	1	1	-
28	900010013	HR spray gun base	1	1	-
	900010009	LR - MR spray gun base	1	1	-
29	250000037	Securing screw of handle base	2	1	-
30	<b>910006118</b>	<b>Air nipple</b>	<b>1</b>	<b>1</b>	-
31	J2FTCF018	O-ring FKM black (included in item30)	2	1	2
32	J3STKL018	O-ring chemically inert white (included in item30)	1	1	2
33	<b>910015869</b>	<b>Electropneumatic coupling sets</b> ( <a href="#">see § 8.11 page 67</a> )	<b>1</b>	<b>1</b>	-
34	<b>910014166</b>	<b>Lateral tape equipped</b> (included in item 12)	<b>1</b>	<b>1</b>	-
35	J2FTDF121	O-ring FKM black (included in item 34)	1	1	2
36	250000214	Elbow securing screw	1	1	-
37	900010605	55° elbow	1	1	-
38	129670405	Rotating air coupling	option	1	2
39**	J2FTDF121	O-ring FKM black (included in item 40)	1	1	2
40**	<b>910015931</b>	<b>Paint nut equipped</b>	<b>1</b>	<b>1</b>	-
41**	J2FTCF178	O-ring FKM black (included in item 40)	1	1	2
42	-	Paint hose ( <a href="#">see § 8.12 page 68</a> )	1	-	-

(\*) Level 1: 1st emergency parts  
Level 2: Wearing parts

\*\* Except MR version [see § 8.12.3 page 69](#)

### 8.5. Barrel assembly

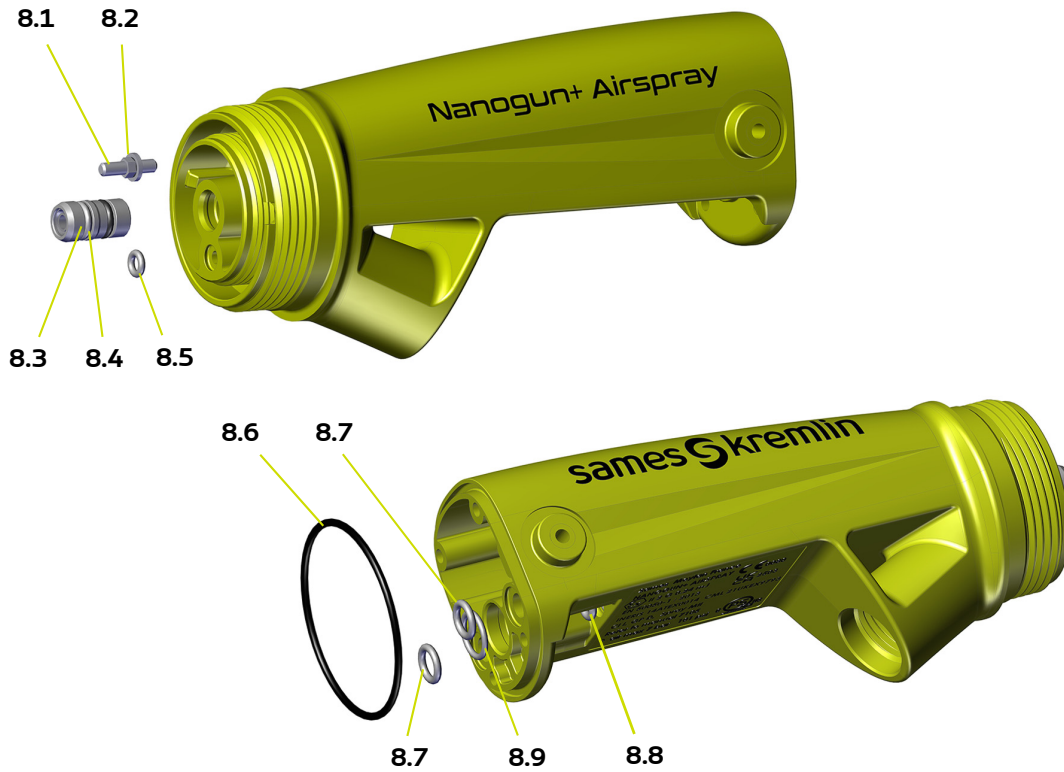

Item	Part number	Description	Qty	Unit of sale	Spare Part Level (*)
<b>8</b>	<b>910018202</b>	<b>Barrel assembly</b>	<b>1</b>	<b>1</b>	<b>-</b>
<b>8.1</b>	1407354	HV contact	1	1	1
<b>8.2</b>	J2CRAN031	Sealing ring of contact	1	1	-
<b>8.3</b>	<b>910014338</b>	<b>Seal cartridge</b>	<b>1</b>	<b>1</b>	<b>1-2</b>
<b>8.4</b>	J3STKL005	O-ring, chemically inert (included in item 8.3)	1	1	2
<b>8.5</b>	J3STKL002	O-ring, chemically inert	1	1	2
<b>8.6</b>	J2FENV435	O-ring FEP viton	1	1	2
<b>8.7</b>	J3STKL078	O-ring, chemically inert	2	1	2
<b>8.8</b>	J3STKL032	O-ring, chemically inert	1	1	2
<b>8.9</b>	J3STKL019	O-ring, chemically inert	1	1	2

(\*)

Level 1: 1st emergency parts

Level 2: Wearing parts

## 8.6. Air valve and air valve nut

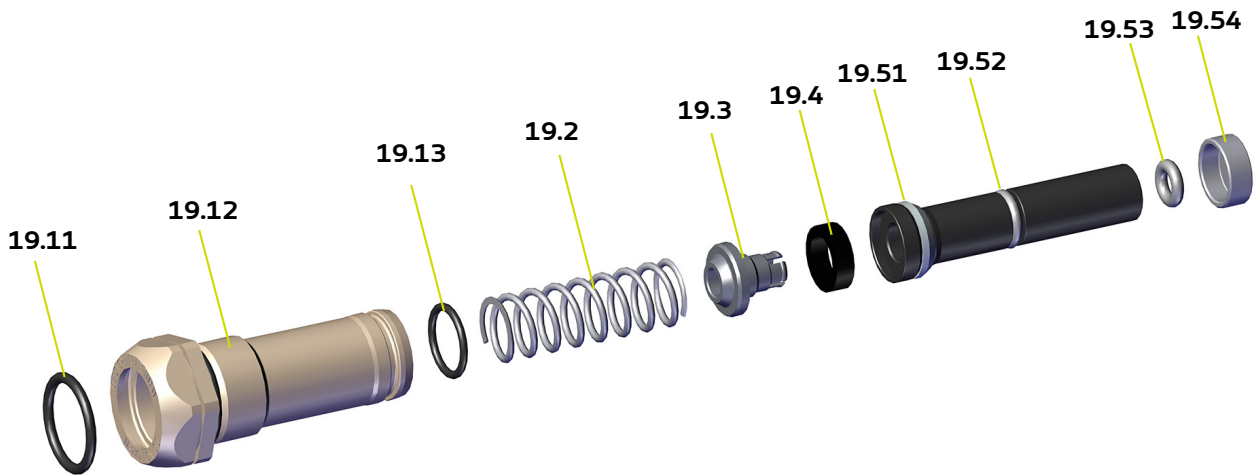

Item	Part number	Description	Qty	Unit of sale	Spare Part Level (*)
<b>19</b>	-	<b>Air valve and air valve nut assembly</b>	<b>1</b>	-	-
<b>19.1</b>	<b>910015922</b>	<b>Air valve nut assembly</b>	<b>1</b>	<b>1</b>	-
<b>19.11</b>	J2FTDF155	O-ring, FKM black	1	1	1
<b>19.12</b>	J2FTDF160	O-ring, FKM black	1	1	1-2
<b>19.13</b>	J2FTDF999	O-ring, FKM black	1	1	1-2
<b>19.3</b>	-	Magnet stop	1	-	-
<b>19.4</b>	-	Magnet	1	-	-
<b>19.2</b>	900009024	Air spring	1	1	-
<b>19.5</b>	<b>910018203</b>	<b>Air valve</b>	<b>1</b>	<b>1</b>	<b>1</b>
<b>19.51</b>	900010256	Sealing ring	1	1	2
<b>19.52</b>	J3STKL005	O-ring, chemically inert (outer of valve)	1	1	2
<b>19.53</b>	J3STKL032	O-ring, chemically inert (inner of valve)	1	1	2
<b>19.54</b>	900020022	Valve support washer	1	1	2

(\*)

**Level 1: 1st emergency parts**

**Level 2: Wearing parts**



**Recover the magnet (Item 19.4) by memorising the mounting direction on the old air valve to keep the same values of triggering.**

**If the magnet is lost, contact Sames ([see § 6.4.5.1 page 48](#)).**



### 8.7. Air cap ring

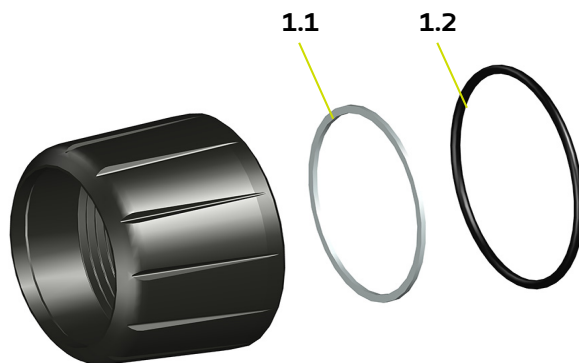

Item	Part number	Description	Qty	Unit of sale	Spare Part Level (*)
<b>1</b>	<b>910015921</b>	<b>Air cap ring</b>	<b>1</b>	<b>1</b>	<b>1</b>
<b>1.1</b>	900010497	Slide ring	1	1	1-2
<b>1.2</b>	J2FENV445	O-ring FEP/FKM	1	1	1-2

(\*)

Level 1: 1st emergency parts

Level 2: Wearing parts

### 8.8. Nozzle support

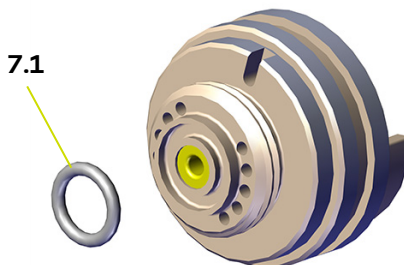

Item	Part number	Description	Qty	Unit of sale	Spare Part Level (*)
<b>7</b>	<b>910015721</b>	<b>Nozzle support - LP Models</b>	<b>1</b>	<b>1</b>	<b>1-2</b>
<b>7.1</b>	J3STKL094	O-ring - chemically inert	1	1	2

(\*)

Level 1: 1st emergency parts

Level 2: Wearing parts

8.9. Round Nozzle assemblies - LP Models

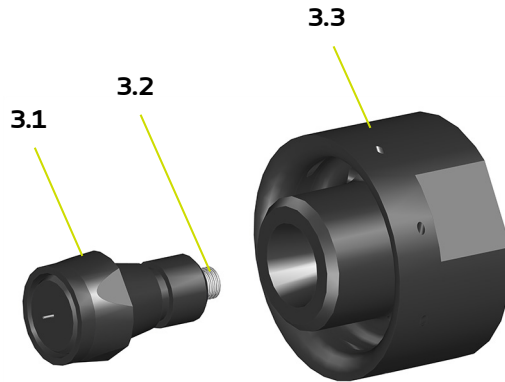

Item	Part number	Description	Qty	Unit of sale	Spare Part Level (*)
<b>3</b>	<b>910018322</b>	<b>JR06 Nozzle assembly</b>	<b>1</b>	<b>1</b>	<b>2</b>
<b>3.1</b>	455234	Injector - Calibre 6	1	5	2
<b>3.2</b>	448110	Electrode (included in item3.1)	1	10	1-2
<b>3.3</b>	1305211	Vortex Nozzle	1	1	1-2

Item	Part number	Description	Qty	Unit of sale	Spare Part Level (*)
<b>3</b>	<b>910003847</b>	<b>JR08 Nozzle assembly</b>	<b>1</b>	<b>1</b>	<b>2</b>
<b>3.1</b>	455235	Injector - Calibre 8	1	5	2
<b>3.2</b>	448110	Electrode (included in item3.1)	1	10	1-2
<b>3.3</b>	1305211	Vortex Nozzle	1	1	1-2

Item	Part number	Description	Qty	Unit of sale	Spare Part Level (*)
<b>3</b>	<b>910003920</b>	<b>JR12 Nozzle assembly</b>	<b>1</b>	<b>1</b>	<b>2</b>
<b>3.1</b>	455236	Injector - Calibre 12	1	5	2
<b>3.2</b>	448110	Electrode (included in item3.1)	1	10	1-2
<b>3.3</b>	1305211	Vortex Nozzle	1	1	1-2

(\*)

Level 1: 1st emergency parts

Level 2: Wearing parts

### 8.10. Needle assembly

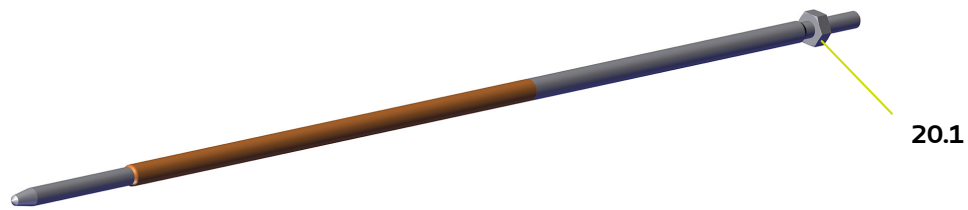

Item	Part number	Description	Qty	Unit of sale	Spare Part Level (*)
20	910018219	Needle assembly	1	1	1-2
20.1	X7CEHU003	Brass H M3 U nut	1	1	-

(\*)  
Level 1: 1st emergency parts  
Level 2: Wearing parts

### 8.11. Electropneumatic coupling sets



Item	Part number	Description	Qty	Unit of sale	Spare Part Level (*)
33	910015869-100	HR-LR 10m Electropneumatic coupling	1	1	-
	910015869-200	HR-LR 20m Electropneumatic coupling	1	1	-
33.1	900015289	Straight union - male	1	1	-
33.2	910021087-100	Polyurethane air hose - Ext. D: 10	10 m	m	2
	910021087-200		20 m		
33.3	F6RLHG362	Female NPT / Male BSP adapter	option	1	-
33.4	130000527	Quick coupling	1	1	-

## 8.12. Paint hoses

### 8.12.1. For Nanogun+ Airspray Low Pressure and High Resistivity spray guns

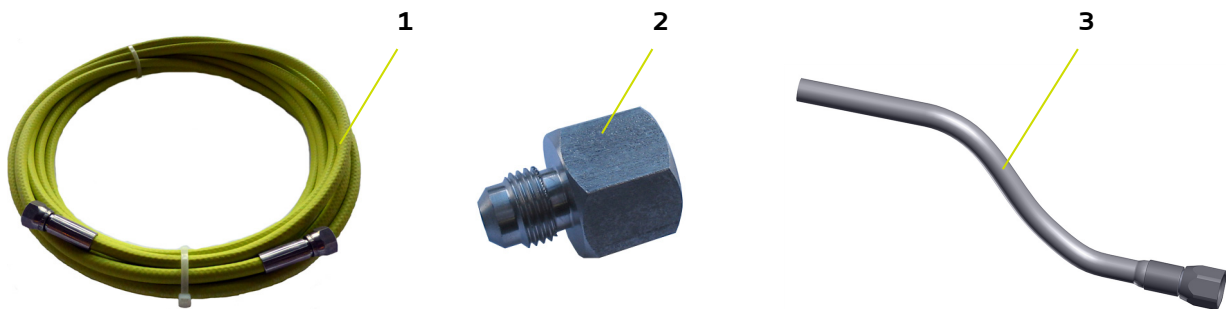

Item	Part number	Description	Qty	Unit of sale	Spare Part Level
<b>42</b>	<b>For Nanogun+ Airspray JR/JP spray guns</b>				
<b>42.1</b>	<b>910017065-075</b>	<b>HR/LP product hose - 7.5m Dia 6</b>	<b>1</b>	<b>1</b>	<b>1-2</b>
	<b>910017065-150</b>	<b>HR/LP product hose - 15m Dia 6</b>	<b>1</b>	<b>1</b>	<b>1-2</b>
<b>42.2</b>	050123306	M1/2" JIC adapter - F3/8NPS	1	1	-
<b>42.3</b>	910018201	Paint hose equipped Dia:4 mm	1	1	1-2
	<b>910018200</b>	<b>Set of olives for outer 10 hoses</b> (included in item 42.3)	<b>1</b>	<b>1</b>	<b>-</b>

### 8.12.2. For Nanogun+ Airspray Low Pressure and Low Resistivity spray guns



Item	Part number	Description	Qty	Unit of sale	Spare Part Level (*)
<b>42</b>	<b>For Nanogun+ Airspray JR/JP spray guns</b>				
<b>42.4</b>	<b>910020516-075</b>	<b>LR /LP product hose - 7.5m PTFE Dia 6</b>	<b>1</b>	<b>1</b>	<b>1-2</b>
	<b>910020516-150</b>	<b>LR /LP product hose - 15m PTFE Dia 6</b>	<b>1</b>	<b>1</b>	<b>1-2</b>
<b>42.5</b>	910018200	Set of olives for outer 10 hoses	1	1	-
<b>42.6</b>	910018292	Stuffing box and nut	1	1	-

(\*)

Level 1: 1st emergency parts

Level 2: Wearing parts

8.12.3. For Nanogun+ Airspray Low Pressure and middle Resistivity spray guns

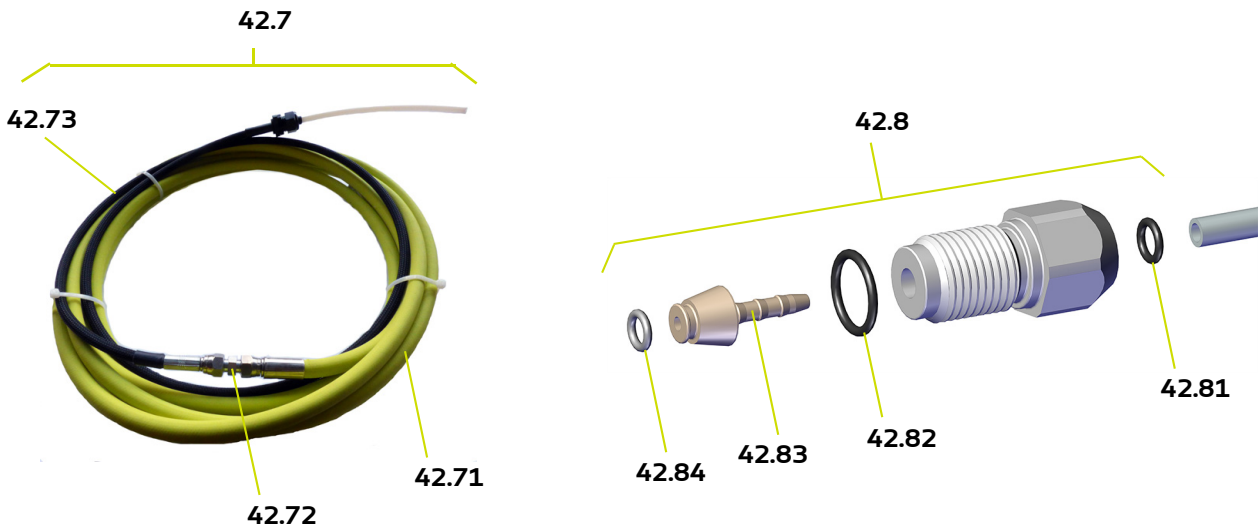

Item	Part number	Description	Qty	Unit of sale	Spare Part Level (*)
<b>42</b>	<b>For Nanogun+ Airspray JR/JP spray guns</b>				
<b>42.7</b>	910025601-075	MR/LP PTFE product hose- 7,5m Ø 4x8	1	1	1-2
	910025601-150	MR/LP PTFE product hose 15m Ø 4x8	1	1	1-2
<b>42.71</b>	910026304-075	Hose extension, length: 7,5 m (included in Item 42.7)	1	1	2
	910026304-150	Hose extension, length: 15 m (included in Item 42.7)	1	1	2
<b>42.72</b>	050102301	Steel coupling MM 1/2" JIC (included in item 42.7)	1	1	-
<b>42.73</b>	910026302	Whip for Nanogun+ Airspray LP MR (included in Item 42.7)	1	1	2
<b>42.8</b>	910020041	Hose paint nut with o-rings	1	1	-
<b>42.81</b>	J2FTDF106	O-ring viton (included in Item 42.8)	1	1	2
<b>42.82</b>	J2FTCF178	O-ring viton (inclus dans Rep.42.8)	1	1	2
<b>42.83</b>	900010707	Paint male connector	1	1	-
<b>42.84</b>	J3STKL005	O-ring chemically inert	1	1	2

(\*)

Level 1: 1st emergency parts

Level 2: Wearing parts

### 8.13. Nanogun+ Airspray seal set

Part number	Description	Location	Quantity
<b>910021244</b>	<b>Nanogun+ Airspray seal set</b>		<b>1</b>
J3STKL005	Chemically inert O-ring	Air valve, on/off button seal cartridge	3
J2FENV435	FEP/FKM O-ring	Barrel	1
J3STKL078	Chemically inert O-ring	Barrel	2
J3STKL019	Chemically inert O-ring	Barrel	1
J3STKL002	Chemically inert O-ring	Barrel	1
910014338	Seal cartridge	Barrel	1
J3STKL032	Chemically inert O-ring	Barrel, air valve	2
160000041	Chemically inert O-ring	Handle	1
160000067	Red FKM O-ring	Handle	1
J2FTCF018	Black FKM O-ring	Air nipple	2
J3STKL018	Chemically inert O-ring	Air nipple	1
J4BRND039	Fiber seal	Handle-barrel fastening, base-handle fastening	6
900010256	Sealing ring	Air valve	1
J3STKL094	Chemically inert O-ring	Nozzle support	1

### 8.14. GNM 6080 Control module



Part number	Description	Qty	Unit of sale	Spare Part Level
<b>910017193</b>	<b>EU/UK GNM 6080 control module</b>	<b>1</b>	<b>1</b>	<b>-</b>
<b>910017192</b>	<b>GNM 6080 control module (USA-CANADA only)</b>	<b>1</b>	<b>1</b>	<b>-</b>
<b>910005759</b>	<b>GNM 6080 attachment kit</b>	<b>1</b>	<b>1</b>	<b>-</b>
842635	5-m ground cable, lug dia.: 6	1	1	-

(\*)

**Level 1: 1st emergency parts**

**Level 2: Wearing parts**

## 8.15. Options for Nanogun+ Airspray Low Pressure spray guns

### 8.15.1. Flat Spray Air Caps

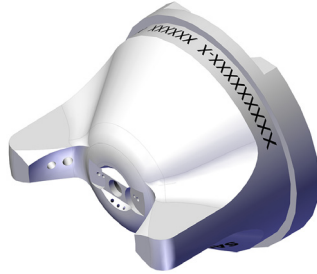

Part number	Description	Qty	Unit of sale	Spare Part Level (*)
737549	Air Cap (flat spray)	Option	1	1-2
737550	SPE Air Cap (narrow flat spray)	Option	1	1-2
737552	SPL Air Cap (broad flat spray)	Option	1	1-2

(\*)

**Level 1: 1st emergency parts**

**Level 2: Wearing parts**

### 8.15.2. In-line product filters

These small filters are fitted in the spray gun handle (with HR models).

Description	Part number	Versions
Filter (Male-Female 1/2 JIC)	155010100	LP HR
Screen nr 12	129609909	



**The filter is delivered with a 6mm screen as standard. Before installation of low pressure models, you are advised to replace the screen nr 6 from the initial design with a screen nr 12.**

With LR models, it is necessary to remove the fitting F 3/8 NPT- M1/2 JIC located at the pump outlet and to replace it by the filter.

## 8.16. Various

### 8.16.1. Protective hose covering

This covering can be used to protect hoses and cables to ensure long life and flexibility.

Description	Part number	Unit of sale
 <p>Rilsan Protective hose covering with 30 collars</p>	910021086	50 m roll

### 8.16.2. Protective case for spray gun

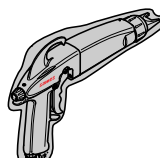
Description	Part number	Unit of sale
 <p>Protective case</p>	900011711	10

### 8.16.3. Warning notice

Description	Part number	Unit of sale
 <p>Warning notice</p>	1407684	1

### 8.16.4. Safety valve

Description	Part number	Unit of sale
 <p>Safety valve 6.5 bar 1/4 G</p>	903080401	1



## 9. The different versions

### 9.1. Equipments

<b>Titre</b>	<b>Pistolet Nanogun Airspray "Basse pression" LP</b>		
<i>Title</i>	<i>Nanogun Airspray Gun type "low pressure"LP</i>		
	Pistolet Nanogun Airspray CE+UK+C/US		
<b>N° GUN</b>	<b>PISTOLET "Basse pression" LP / "Haute résistivité " HR</b>		
	<i>Low Pressure/High Resitivity GUN</i>		
	<b>CE+UK+C/US</b>		
910016710	HAUTE RESISTIVITE JET PLAT		
910018773	HAUTE RESISTIVITE JET ROND Ø6		
910016712	HAUTE RESISTIVITE JET ROND Ø8		
910016711	HAUTE RESISTIVITE JET ROND Ø12		
910017188-075	BASSE RESISTIVITE JET PLAT LG 7,5M		
910017188-150	BASSE RESISTIVITE JET PLAT LG 15M		
910018774-075	BASSE RESISTIVITE JET ROND Ø6 LG7,5M		
910018774-150	BASSE RESISTIVITE JET ROND Ø6 LG15M		
910017190-075	BASSE RESISTIVITE JET ROND Ø8 LG7,5M		
910017190-150	BASSE RESISTIVITE JET ROND Ø8 LG15M		
910017189-075	BASSE RESISTIVITE JET ROND Ø12 LG7,5M		
910017189-150	BASSE RESISTIVITE JET ROND Ø12 LG15M		
<b>N° GUN</b>	<b>EQUIPEMENT Nanogun Airspray CE+UK</b>	<b>N° GUN</b>	<b>EQUIPEMENT Nanogun Airspray C/US</b>
	<i>SET Nanogun Airspray CE+UK</i>		<i>SET Nanogun Airspray C/US</i>
910017223-07	E.NANOGUN LP/HR JP LG7,5 EU	910017223-072	E.NANOGUN LP/HR JP LG7,5 US
910017223-15	E.NANOGUN LP/HR JP LG15 EU	910017223-152	E.NANOGUN LP/HR JP LG15 US
910017224-07	E.NANOGUN LP/HR JRØ8 LG7,5 EU	910017224-072	E.NANOGUN LP/HR JRØ8 LG7,5 US
910017224-15	E.NANOGUN LP/HR JRØ8 LG15 EU	910017224-152	E.NANOGUN LP/HR JRØ8 LG15 US
910017741-07	E.NANOGUN LP/HR JRØ12 LG7,5	910017741-072	E.NANOGUN LP/HR JRØ12 LG7,5US
910017741-15	E.NANOGUN LP/ HR JRØ12 LG15 EU	910017741-152	E.NANOGUN LP/ HR JRØ12 LG15 US
910017221-07	E.NANOGUN LP/LR JP LG7,5 EU	910017221-072	E.NANOGUN LP/LR JP LG7,5 US
910017221-15	E.NANOGUN LP/LR JP LG15 EU	910017221-152	E.NANOGUN LP/LR JP LG15 US
910017222-07	E.NANOGUN LP/LR JRØ8 LG7,5 EU	910017222-072	E.NANOGUN LP/LR JRØ8 LG7,5 US
910017222-15	E.NANOGUN LP/LR JRØ8 LG15 EU	910017222-152	E.NANOGUN LP/LR JRØ8 LG15 US
910017742-07	E.NANOGUN LP/LR JRØ12 LG7,5 EU	910017742-072	E.NANOGUN LP/LR JRØ12 LG7,5 US
910017742-15	E.NANOGUN LP/LR JRØ12 LG15 EU	910017742-152	E.NANOGUN LP/LR JRØ12 LG15 US
<b>N°</b>	<b>Module GNM 6080 CE+UK</b>	<b>N°</b>	<b>Module GNM 6080 C/US</b>
	<i>Control module GNM 6080 CE+UK</i>		<i>Control module GNM 6080 C/US</i>
910017193	MODULE DE COMMANDE GNM 6080 VERSION EUROPE	910017192	MODULE DE COMMANDE GNM 6080 VERSION US
<b>N°</b>	<b>CABLE Nanogun Airspray CE+UK+C/US</b>		
	<i>Cable Nanogun Airspray CE+UK+C/US</i>		
910015869-100	CABLE ELECTRO 10 Mètres		
910015869-200	CABLE ELECTRO 20 Mètres		
<b>N°</b>	<b>TUYAU PRODUIT Nanogun Airspray CE+UK+C/US</b>		
	<i>Hose Nanogun Airspray CE+UK+C/US</i>		
910017065-075	Tuyau produit HR-7,5M		
910017065-150	Tuyau produit HR-15M		
910020516-075	Tuyau produit LR-7,5M		
910020516-150	Tuyau produit LR-15M		

DES05994

<b>Titre</b>	<b>Pistolet Nanogun Airspray "Basse pression" LP</b>		
<i>Title</i>	<i>Nanogun Airspray Gun type "low pressure"LP</i>		
	Pistolet Nanogun Airspray CE+UK+C/US		
	<b>PISTOLET "Basse pression" LP / Moyenne résistivité " MR</b>		
<b>N° GUN</b>	<i>Low Pressure/Middle Resistivity GUN</i>		
	<b>CE+UK+C/US</b>		
<b>910025604-075</b>	<b>MOYENNE RESISTIVITE JET ROND Ø8</b>		
<b>910025604-150</b>	<b>MOYENNE RESISTIVITE JET ROND Ø8</b>		
<b>910025605-075</b>	<b>MOYENNE RESISTIVITE JET ROND Ø12</b>		
<b>910025605-150</b>	<b>MOYENNE RESISTIVITE JET ROND Ø12</b>		
<b>910025606-075</b>	<b>MOYENNE RESISTIVITE JET PLAT</b>		
<b>910025606-150</b>	<b>MOYENNE RESISTIVITE JET PLAT</b>		
	<b>EQUIPEMENT Nanogun Airspray CE+UK</b>		<b>EQUIPEMENT Nanogun Airspray C/US</b>
<b>N° GUN</b>	<i>SET Nanogun Airspray CE+UK</i>	<b>N° GUN</b>	<i>SET Nanogun Airspray C/US</i>
<b>910025622-07</b>	<b>E.NANOGUN LP/MR JP LG7,5 EU</b>	<b>910025622-072</b>	<b>E.NANOGUN LP/MR JP LG7,5 US</b>
<b>910025622-15</b>	<b>E.NANOGUN LP/MR JP LG15 EU</b>	<b>910025622-152</b>	<b>E.NANOGUN LP/MR JP LG15 US</b>
<b>910025620-07</b>	<b>E.NANOGUN LP/MR JRØ8 LG7,5 EU</b>	<b>910025620-072</b>	<b>E.NANOGUN LP/MR JRØ8 LG7,5 US</b>
<b>910025620-15</b>	<b>E.NANOGUN LP/MR JRØ8 LG15 EU</b>	<b>910025620-152</b>	<b>E.NANOGUN LP/MR JRØ8 LG15 US</b>
<b>910025621-07</b>	<b>E.NANOGUN LP/MR JRØ12 LG7,5 EU</b>	<b>910025621-072</b>	<b>E.NANOGUN LP/MR JRØ12 LG7,5 US</b>
<b>910025621-15</b>	<b>E.NANOGUN LP/MR JRØ12 LG15 EU</b>	<b>910025621-152</b>	<b>E.NANOGUN LP/MR JRØ12 LG15 US</b>
	<b>Module GNM 6080 CE+UK</b>		<b>Module GNM 6080 C/US</b>
<b>N°</b>	<i>Control module GNM 6080 CE+UK</i>	<b>N°</b>	<i>Control module GNM 6080 C/US</i>
<b>910017193</b>	<b>MODULE DE COMMANDE GNM 6080 VERSION EUROPE</b>	<b>910017192</b>	<b>MODULE DE COMMANDE GNM 6080 VERSION US</b>
	<b>CABLE Nanogun Airspray CE+UK+C/US</b>		
<b>N°</b>	<i>Cable Nanogun Airspray CE+UK+C/US</i>		
<b>910015869-100</b>	<b>CABLE ELECTRO 10 Mètres</b>		
<b>910015869-200</b>	<b>CABLE ELECTRO 20 Mètres</b>		
	<b>TUYAU PRODUIT Nanogun Airspray CE+UK+C/US</b>		
<b>N°</b>	<i>Hose Nanogun Airspray CE+UK+C/US</i>		
<b>910025601-075</b>	<b>Tuyau produit MR-7,5M</b>		
<b>910025601-150</b>	<b>Tuyau produit MR-15M</b>		

DIS06947

9.2. Configuration

Configuration	Code article	GN16580 CE	GN16580 US/CSA	Liaison électro 10m	Liaison électro 20m	Tuyau produit HR 7,5m	Tuyau produit HR 15m	Tuyau produit LR 7,5m	Tuyau produit LR 15m	Tuyau produit MR 7,5m	Tuyau produit MR 15m	Injeteur / Chapeau 455234 900011385	Injeteur / Chapeau 455235 900010503	Injeteur / Chapeau 455236 900010504	Injeteur / Chapeau 1406402 900009014
<b>Pistolets</b>															
Pistolet LP HR jet plat	910018710														
Pistolet LP HR jet rond JR 06	910018773														
Pistolet LP HR jet rond JR 08	910018712														
Pistolet LR jet rond JR 12	910018711											X			X
<b>Pistolet LP LR jet plat</b>	910017188-075							X					X		
Pistolet LP LR jet rond JR 06	910017188-150							X							X
Pistolet LP LR jet rond JR 08	910018774-075							X							X
Pistolet LP LR jet rond JR 06	910018774-150							X							X
Pistolet LP LR jet rond JR 08	910017190-075							X							X
Pistolet LP LR jet rond JR 06	910017190-150							X							X
Pistolet LP LR jet rond JR 08	910017189-075							X							X
Pistolet LP LR jet rond JR 12	910017189-150							X							X
<b>Equipements</b>															
Equip. Nanogun Akspray LP/HR JP LG 7,5 EU	910017223-07	X													X
Equip. Nanogun Akspray LP/HR JP LG 15 EU	910017223-15	X				X									X
Equip. Nanogun Akspray LP/HR JR 8 LG 7,5 EU	910017224-07	X		X		X							X		X
Equip. Nanogun Akspray LP/HR JR 8 LG 15 EU	910017224-15	X		X		X							X		X
Equip. Nanogun Akspray LP/HR JR12 LG 7,5 EU	910017241-07	X		X		X							X		X
Equip. Nanogun Akspray LP/HR JR12 LG 15 EU	910017241-15	X		X		X							X		X
Equip. Nanogun Akspray LP/LR JP LG 7,5 EU	910017221-07	X		X				X							X
Equip. Nanogun Akspray LP/LR JP LG 15 EU	910017221-15	X		X				X							X
Equip. Nanogun Akspray LP/LR JR 8 LG 7,5 EU	910017222-07	X		X		X		X					X		X
Equip. Nanogun Akspray LP/LR JR 8 LG 15 EU	910017222-15	X		X		X		X					X		X
Equip. Nanogun Akspray LP/LR JR12 LG 7,5 EU	910017242-07	X		X		X		X					X		X
Equip. Nanogun Akspray LP/LR JR12 LG 15 EU	910017242-15	X		X		X		X					X		X
Equip. Nanogun Akspray LP/HR JP LG 7,5 US/CSA	910017223-072		X												X
Equip. Nanogun Akspray LP/HR JP LG 15 US/CSA	910017223-152		X			X									X
Equip. Nanogun Akspray LP/HR JR 8 LG 7,5 US/CSA	910017224-072		X	X		X							X		X
Equip. Nanogun Akspray LP/HR JR 8 LG 15 US/CSA	910017224-152		X	X		X							X		X
Equip. Nanogun Akspray LP/LR JP LG 7,5 US/CSA	910017221-072		X	X				X							X
Equip. Nanogun Akspray LP/LR JP LG 15 US/CSA	910017221-152		X	X				X							X
Equip. Nanogun Akspray LP/LR JR 8 LG 7,5 US/CSA	910017222-072		X	X		X		X					X		X
Equip. Nanogun Akspray LP/LR JR 8 LG 15 US/CSA	910017222-152		X	X		X		X					X		X
Equip. Nanogun Akspray LP/LR JR12 LG 7,5 US/CSA	910017242-072		X	X		X		X					X		X
Equip. Nanogun Akspray LP/LR JR12 LG 15 US/CSA	910017242-152		X	X		X		X					X		X
Equip. Nanogun Akspray LP/HR JP LG 7,5 EU	910025622-07	X		X						X					X
Equip. Nanogun Akspray LP/HR JP LG 15 EU	910025622-15	X		X						X					X
Equip. Nanogun Akspray LP/HR JR 8 LG 7,5 EU	910025620-07	X		X		X				X			X		X
Equip. Nanogun Akspray LP/HR JR 8 LG 15 EU	910025620-15	X		X		X				X			X		X
Equip. Nanogun Akspray LP/HR JR12 LG 7,5 EU	910025621-07	X		X		X				X			X		X
Equip. Nanogun Akspray LP/HR JR12 LG 15 EU	910025621-15	X		X		X				X			X		X
Equip. Nanogun Akspray LP/HR JP LG 7,5 US/CSA	910025622-072		X	X						X					X
Equip. Nanogun Akspray LP/HR JP LG 15 US/CSA	910025622-152		X	X						X					X
Equip. Nanogun Akspray LP/HR JR 8 LG 7,5 US/CSA	910025620-072		X	X		X				X			X		X
Equip. Nanogun Akspray LP/HR JR 8 LG 15 US/CSA	910025620-152		X	X		X				X			X		X
Equip. Nanogun Akspray LP/HR JR12 LG 7,5 US/CSA	910025621-072		X	X		X				X			X		X
Equip. Nanogun Akspray LP/HR JR12 LG 15 US/CSA	910025621-152		X	X		X				X			X		X

## 10. Revision index History

Created by		Checked by: G Fournel	Approved by S. Court
Date	By:	Index	Purpose of the modification and location
2014	S. Court	A	First Issue
2022/11	S. Court	G	Adding UKCA marking Transfer of CSA certification to QPS Change of identity and logo Update of the graphic charter Adding the 4-finger trigger § 8.4 New HR and LR bases § 8.4 Adding shoulderd washer on air valve § 8.4, 8.6 and § 6.4.6 Adding of needle adjustment procedure §6.4.4.1

## **11. Appendices**

### **11.1. Preventive maintenance plan**

PLAN DE MAINTENANCE PREVENTIVE / PREVENTIVE MAINTENANCE PLAN

Numéro d'ordre Serial	Ensemble - Assembly	Sous ensemble Sub assembly	Désignation de l'élément Designation of the assembly	Pour 1 ensemble - For 1 assembly			Acteurs Métiers Operators - skill (3)				Niveau Level (4)		Manuel d'utilisation Instruction manual	Outil Tool	Commentaires Notes	
				Action à effectuer Action to carry out	Temps prévu Estimated Time (1)		Périodicité Periodicity (H / hour) (2)	M	F	E	A	1				2
					100eme H	mn										
<b>Avant toute intervention, se référer au chapitre sécurité du manuel de l'équipement / Before any intervention, see chapter safety equipment manual</b>																
1	<b>Mettre HORS SERVICE le module GNM 6080 avant de procéder au nettoyage du pulvérisateur</b> <i>Always disconnect the GNM 6080 module before cleaning the atomizer</i>															
2	Corps pulvérisateur <i>Atomizer body</i>	Pulvérisateur <i>Atomizer</i>	Contrôle fuite <i>Leakage control</i>	3,33	2	8	-	1	-	-	-	-	-	-	A chaque arrêt de production <i>Every break time</i>	
3	Corps pulvérisateur <i>Atomizer body</i>	Corps pulvérisateur <i>Atomizer body</i>	Nettoyage extérieur <i>Cleaning exterior</i>	8,33	5	8	1	-	-	-	-	-	-	-	A chaque arrêt de production <i>Every break time</i>	
4	Corps pulvérisateur <i>Atomizer body</i>	Pulvérisateur <i>Atomizer</i>	Nettoyage <i>Cleaning</i>	8,33	5	8	1	-	-	-	-	-	-	-	A chaque arrêt de production <i>Every break time</i>	
5	<b>Utiliser des récipients métalliques de capacité inférieure à 20 litres pour contenir les liquides nécessaires aux opérations de nettoyage</b> <i>Use metal containers with a capacity below 20 liters to contain liquids required for cleaning operations</i> <b>Les récipients métalliques doivent impérativement être relié à la terre pour évacuer les charges électrostatiques</b> <i>Metal containers must be grounded to discharge electrostatic charges</i>															
6	Équipement <i>Equipment</i>	Pistolet <i>Gun</i>	Rinçage sans la buse jusqu'à sortie solvant propre <i>Rinsing without nozzle output to the clean solvent</i>	3,33	2	8	-	1	-	-	-	-	-	-	A chaque fin de production <i>At each end of production</i>	
7	Canon <i>Barrel</i>	Contact haute tension <i>High voltage contact</i>	Propreté et état contact haute tension <i>Cleanliness and state high voltage contact</i>	3,33	2	40	-	1	-	-	-	-	-	-	A chaque fin de production <i>At each end of production</i>	
7	Pistolet <i>Gun</i>	Corps pistolet <i>Gun body</i>	Nettoyage extérieur <i>Cleaning exterior</i>	8,33	5	8	1	-	-	-	-	-	-	-	En prévention, enduire le corps de vaseline ou mettre une housse <i>Prevention, coat the body with Vaseline or put a cover</i> A chaque fin de production <i>At each end of production</i>	
8	Équipement <i>Equipment</i>	Câblage <i>Wiring</i>	Vérification hygiène connectique <i>Checking wiring</i>	1,66	1	8	-	-	1	-	-	-	-	-	A chaque fin de production <i>At each end of production</i>	

PLAN DE MAINTENANCE PREVENTIVE / PREVENTIVE MAINTENANCE PLAN

Numéro d'ordre Serial	Ensemble - Assembly	Sous ensemble Sub assembly	Désignation de l'élément Designation of the assembly	Pour 1 ensemble - For 1 assembly			Acteurs Métiers Operators - skill (3)				Niveau Level (4)		Manuel d'utilisation Instruction manual	Outil Tool	Commentaires Notes	
				Action à effectuer Action to carry out	Temps prévu Estimated Time (1)		Périodicité Periodicity (H / hour) (2)	M	F	E	A	1				2
					100eme H	mn										
9	Pistolet NANOGUN+ Airspray Versions LR- HR- MR Nanogun+ Airspray gun LR- HR- MR version	Équipement Equipment	Tuyau peinture Paint hose	Vérification hygiène tuyau peinture Checking paint hose	1,66	1	8	-	-	1	-			A chaque fin de production At each end of production		
10		Équipement Equipment	Tuyau pneumatique Pneumatic hose	Vérification hygiène tuyau air Checking air hose	1,66	1	8	-	-	1	-			A chaque fin de production At each end of production		
11		Équipement Equipment	Outillage spécifique Specific tool	Contrôle visuel Visual control	3,33	2	40	1	-	-	-					
12		Pulvérisateur Atomizer	Buse Nozzle	Nettoyage des orifices de sorties Cleaning of the openings of exits	8,33	5	40	1	-	-	-					
13		Canon Barrel	Contact haute tension High voltage contact	Complément graisse diélectrique Dielectric grease supplement	3,33	2	40	-	1	-	-			A chaque fin de production At each end of production Graisse diélectrique/Dielectric grease : H1GSYN037		
13		Équipement Equipment	Support de buse Nozzle support	Nettoyage des orifices de sorties Cleaning of the openings of exits	8,33	5	40	1	-	-	-		900010674			
14		Équipement Equipment	Bague de tête Ring of head	Complément vaseline Vaseline supplement	3,33	2	40	1	-	-	-		900010674			
15		Buse Nozzle	Buse jet plat Fan spray	Film gras A greasy film	3,33	2	40	1	-	-	-					
16		Canon Barrel	Joint cartouche porte joints O ring seal cartridge	Remplacement Replacement	3,33	2	500	1	-	-	-		240000301			
17		Équipement Equipment	Joint support de buse O ring nozzle support	Remplacement Replacement	3,33	2	500	1	-	-	-		240000301			
18	Canon Barrel	Contact haute tension High voltage contact	Contrôle visuel Visual control	3,33	2	500	1	-	-	-		900010674				
19	Canon Barrel	Contact haute tension High voltage contact	Complément graisse diélectrique Dielectric grease supplement	3,33	2	500	1	-	-	-			Graisse diélectrique/Dielectric grease : H1GSYN037			
20	Canon Barrel	Joint canon sortie produit O ring output paint	Remplacement Replacement	3,33	2	1000	1	-	-	-		240000301				

PLAN DE MAINTENANCE PREVENTIVE / PREVENTIVE MAINTENANCE PLAN

Numéro d'ordre Serial	Ensemble - Assembly	Sous ensemble Sub assembly	Désignation de l'élément Designation of the assembly	Pour 1 ensemble - For 1 assembly			Acteurs Métiers Operators - skill (3)	Niveau Level (4)		Manuel d'utilisation Instruction manual	Outil Tool	Commentaires Notes					
				Action à effectuer Action to carry out	Temps prévu Estimated Time (1)			Périodicité Periodicity (H / hour) (2)	M				F	E	A	1	2
					100eme H	mn											
21		Canon Barrel	Cartouche porte joints Seal cartridge	Remplacement Replacement	3,33	2	1000 ou 500 000 manœuvres *	1	-	-	-			900010674	(*) à l'échéance de l'un des 2 termes at maturity of one of 2 terms		
22		Équipement Equipment	Câblage Wiring	Vérification hygiène connectique Checking wiring	1,66	1	1000 (2 fois/an)	-	-	1	-						
23		Équipement Equipment	Tuyaux et raccords produit Hoses and unions product	Contrôle usure / fuite Wear / Leakage check	3,33	2	1000 (2 fois/an)	1	-	-	-						
24		Paramètre process Process parameter	Unité haute tension High voltage unit	Essais Haute tension High voltage test	3,33	2	1000 (2 fois/an)	-	-	1	-						
25		Pulvérisateur Atomizer	Fixations Fixations	Vérification fixation appareil Checking fixing projector	3,33	2	1000 (2 fois/an)	1	-	-	-						
26		Canon Barrel	Joint canon/crosse O ring barrel/grip	Remplacement Replacement	3,33	2	2000	1	-	-	-			240000301			
27		Canon Barrel	Joints air canon/crosse Air O ring barrel/grip	Remplacement Replacement	3,33	2	2000	1	-	-	-			240000301			
28		Canon Barrel	Joint pointeau canon O ring needle barrel	Remplacement Replacement	3,33	2	2000	1	-	-	-			240000301			
29		Canon Barrel	Joint vanne d'air canon O ring air valve barrel	Remplacement Replacement	3,33	2	2000	1	-	-	-			240000301			
30		Buse Nozzle	Support de buse Nozzle support	Remplacement Replacement	3,33	2	2000	1	-	-	-			900010674			
31		Crosse Handle	Joint connecteur électrique crosse O ring electric connexion handle	Remplacement Replacement	3,33	2	2000	1	-	-	-			240000301			
32		Crosse Handle	Joint embase crosse O ring handle base handle	Remplacement Replacement	3,33	2	2000	1	-	-	-			240000301			
33		Crosse Handle	Joints mamelon d'air crosse O ring air nipple handle	Remplacement Replacement	8,33	5	2000	1	-	-	-			240000301			



PLAN DE MAINTENANCE PREVENTIVE / PREVENTIVE MAINTENANCE PLAN

Numéro d'ordre Serial	Ensemble - Assembly	Sous ensemble Sub assembly	Désignation de l'élément Designation of the assembly	Pour 1 ensemble - For 1 assembly			Acteurs Métiers Operators - skill (3)				Niveau Level (4)		Manuel d'utilisation Instruction manual	Outil Tool	Commentaires Notes	
				Action à effectuer Action to carry out	Temps prévu Estimated Time (1)		Périodicité Periodicity (H / hour) (2)	M	F	E	A	1				2
					100eme H	mn										
34		Équipement <i>Equipment</i>	Canon/crosse <i>Barrel/grip</i>	Remplacement rondelle fibre assemblage crosse et canon <i>Replacement fiber washer assembly handle and barrel</i>	3,33	2	2000	1	-	-	-			Tournevis cruciforme N°2 <i>Phillips screwdriver No2</i>	Ou à chaque démontage <i>Or at each dismantling</i>	
35		Vanne d'air <i>Air valve</i>	Joints extérieur vanne <i>O ring external valve</i>	Remplacement <i>Replacement</i>	8,33	5	2000	1	-	-	-			240000301		
36		Vanne d'air <i>Air valve</i>	Joints intérieur vanne <i>O ring internal valve</i>	Remplacement <i>Replacement</i>	8,33	5	2000	1	-	-	-			240000301		
37		Vanne d'air <i>Air valve</i>	Bague d'étanchéité <i>Sealing ring</i>	Remplacement <i>Replacement</i>	8,33	5	2000	1	-	-	-					
38	<a href="#">(DRT7105)</a>	Pulvérisateur <i>Atomizer</i>	Buse <i>Nozzle</i>	Vérification pulvérisation peinture <i>Checking paint spraying</i>	1,66	1		1	-	-	-				Durant la production <i>During production</i>	
39	<b>Pièces de rechange</b> <i>Spare parts</i>	Stock <i>Stock</i>	Pièces <i>Spare parts</i>	Vérification disponibilité des pièces de première urgence <i>Checking availability of spare parts</i>	8,33	5	2 fois/an	X	X			1	2			

**11.2. EU and UK declarations of conformity**



## UE DECLARATION OF CONFORMITY

(1) The manufacturer herewith declares that the equipment is in conformity with the relevant Union harmonization legislation.

(2) Equipment type	PULVERISATEUR ELECTROSTATIQUE DE PEINTURE / ELECTROSTATIC PAINT SPRAY SYSTEM		
	Nanogun+ Airspray / GNM 6080		
(3) Applicable Directives	(4) Marking	Sprayer Nanogun+ Airspray II 2 G 0.24 mJ	
		Control module GNM 6080 II (2) G [0.24 mJ]	
	2014/34/UE ATEX Directive	Matériel associé GNM 6080 doit être installé en zone sûre (zone non dangereuse) Associated equipment GNM 6080 must be installed in safe zone (non explosive area)	
		(5) Harmonised standards	EN 50050-1 : 2013
		(6) Conformity assessment procedures	UE type examination certificate : INERIS 14ATEX0014
Production Quality Assurance Notification : INERIS 07ATEXQ401			
2014/30/UE Electromagnetic Compatibility Directive	(5) Harmonised standards	EN 61000-6-4 : 2007 /A1 : 2011 EN 61000-6-2 : 2005	
2014/35/UE Low Voltage Directive	(5) Harmonised standards	EN 61010-1 : 2011	
(7) This declaration of conformity is issued under the sole responsibility of the manufacturer.			

**Director of the MEYLAN site - Executive Management (EM)**

Richard WLODARCZYK

DocuSigned by:  
*Richard Wlodarczyk*  
9900D9C0034B4A2...

Established in Meylan, on 03-nov.-22 | 09:24 CET

SAMES

Siège Social / Headquarter: 13, chemin de Malacher - CS70086 - 38243 Meylan Cedex - France - Tél / Phone: +33 (0)4 76 41 60 60  
SAS au capital de 12.720.000 euros | RCS Grenoble: 572 051 688 | Code APE: 2829B | TVA intracom: FR36 572051688  
[info@sames.com](mailto:info@sames.com) - [www.sames.com](http://www.sames.com) | Société d'EXEL Industries / EXEL Industries company



## UE DECLARATION OF CONFORMITY

(1)	<p>Le Fabricant déclare que le matériel désigné ci-après est conforme à la législation d'harmonisation de l'Union applicable suivante/ Der Hersteller erklärt, dass das nachfolgend bezeichnete Material den folgenden anwendbaren Harmonisierungsrechtsvorschriften der Union entspricht / El fabricante declara que el equipo designado a continuación es conforme con la siguiente legislación de armonización de la UE aplicable / Il fabbricante dichiara che l'attrezzatura designata di seguito è conforme alla seguente legislazione di armonizzazione UE applicabile / O Fabricante declara que o equipamento designado abaixo está em conformidade com a seguinte legislação de harmonização aplicável da UE / Producent deklaruje, że urządzenie wskazane poniżej jest zgodne z następującymi obowiązującymi przepisami harmonizacyjnymi UE/ De fabrikant verklaart dat de hieronder beschreven apparatuur in overeenstemming is met de volgende toepasselijke EU-harmonisatiewetgeving/ Výrobce prohlašuje, že níže uvedené zařízení je ve shodě s těmito platnými harmonizačními právními předpisy EU/ Výrobce prohlašuje, že níže uvedené zařízení je ve shodě s těmito platnými harmonizačními právními předpisy EU/ Producenten erklærer, at det nedenfor angivne udstyr er i overensstemmelse med følgende gældende EU-harmoniseringslovgivning/ Valmistaja vakuuttaa, että jäljempänä mainitut laitteet ovat seuraavien sovellettävien EU:n yhdenmukaistamislainsäädäntöjen mukaisia./ Tootja kinnitab, et allpool nimetatud seadmed vastavad järgmistele kohaldatavatele ELi ühtlustamise õigusaktidele./ Ražotājs apliecina, ka turpmāk norādītās iekārtas atbilst šādiem piemērojamiem ES saskaņošanas tiesību aktiem./ Gamintojas pareiškia, kad toliau nurodyta įranga atitinka šiuos taikytinus ES derinamuosius teisės aktus/ Производителят декларира, че посоченото по-долу оборудване е в съответствие със следното приложимо законодателство на ЕС за хармонизация/ A gyártó kijelenti, hogy az alább megjelölt berendezés megfelel a következő alkalmazandó uniós harmonizációs jogszabályoknak / Producătorul declară că echipamentul desemnat mai jos este în conformitate cu următoarea legislație de armonizare a UE aplicabilă/ Ο κατασκευαστής δηλώνει ότι ο εξοπλισμός που αναφέρεται κατωτέρω συμμορφώνεται με την ακόλουθη ισχύουσα νομοθεσία ενωρίμωσης της ΕΕ/ Προϊζводаč ovime izjavljuje da je oprema u skladu sa zakonskim zahtjevima Uje dinjene Kraljevine./ Výrobca vyhlasuje, že nižšie uvedené zariadenie je v súlade s týmito platnými harmonizačnými právnymi predpismi EÚ/ Произвојалец изјављује, да је сподј наведена опрема складна з насљедној вељавној усклајевалној законодајој ЕУ/ Производител заявляет, что указанное ниже оборудование соответствует следующим применимым законодательным актам ЕС по гармонизации/ 製造者は、以下に指定された装置が、適用される以下のEU調和法に適合していることを宣言する。/ 製造商声明, 下面指定的设备符合以下适用的欧盟协调立法。</p>
(2)	<p>Type d'équipement/ Art der Ausrüstung/ Tipo de equipo/ Tipo di attrezzatura/ Tipo de equipamento/ Rodzaj sprzętu/ Type uitrusting/ Typ zařízení/ Typ av anordning/ Type af anordning/ Laitteen tyyppi/ Seadme tüüp/ Iekārtas tips/ Įrangos tipas/ Вид оборудване/ A berendezés típusa/ Tipul de echipament/ Τύπος εξοπλισμού/ Vrsta opreme/ Typ zariadenia/ Vrsta naprave/ Тип оборудовани/ 機器の種類/ 设备类型</p>
(3)	<p>Directives applicables/Anwendbare Richtlinien/Directivas aplicables/Direttive applicabili/Directivas aplicáveis/Obowiązujące dyrektywy/Toepasselijke richtlijnen/Platné smernice/Tillämpliga direktiv/Gældende direktiver/Sovellettavat direktiivit/Kohaldatavad direktiivid/Piemērojamās direktīvas/Taikomos direktyvos/Приложими директиви/Alkalmazandó irányelvek/Directive aplicabile/ισχύουσες οδηγίες/Primjenjive smjernice/Uplatnitelné smernice/Veljavne directive/Применимые директивы/適用される指令/适用的指令</p>
(4)	<p>Marquage/Markierung/Marcado/Marcatura/Marcação/Znakowanie/Markering/Označení/Märkning/Mærkning/Merkintä/Märgistus/Marķējums/Ženklinimas/Маркировка/Jelðis/Marcare/Ἱήμανση/Obilježava/Označovanie /Označevanje/Маркировка/マーキング/ 标识</p>
(5)	<p>Normes harmonisées/Harmonisierte Normen / Normas armonizadas/ Norme armonizate/Normas harmonizadas /Normy zharmonizowane /Geharmoniseerde normen /Harmonizované normy /Harmoniserade standarder /Harmoniserede standarder /Yhdenmukaistetut standardit /Harmoneeritud standardid /Saskaņotie standarti /Suderintai standartai /Хармонизирани стандарти /Harmonizált szabványok / Standarde armonizate/ Евармонизирани прототипа /Harmonizirani standardi /Harmonizované normy /Usklajeni standardi /Гармонизированные стандарты /整合規格 /协调标准</p>
(6)	<p>Procédure d'évaluation de la conformité/Verfahren der Konformitätsbewertung/Procedimiento de evaluación de la conformidad/Procedura di valutazione della conformità/Procedimento de avaliação da conformidade/Procedura oceny zgodności/Conformiteitsbeoordelingsprocedure/Postup posuzování shody / Förfarande för bedömning av överensstämmelse/Procedure for overensstemmelsesvurdering /Vaatimustenmukaisuuden arviointimenettely /Vastavushindamisenetellus/Atbilstības novērtēšanas procedūra /Atitikties vertinimo procedūra /Процедура за оценка на съответствието /Megfelelőségértékelési eljárás / Procedura de evaluare a conformității/Διαδικασία αξιολόγησης της συμμόρφωσης /Postupak ocjene uskladnosti /Postup posudzovanja zhody /Postopek ugotavljanja skladnosti /Процедура оценки соответствия / 適合性評價手順 / 符合性評估程序</p>
(7)	<p>Cette déclaration de conformité est délivrée sous la seule responsabilité du fabricant. / Diese Konformitätserklärung wird unter der alleinigen Verantwortung des Herstellers ausgestellt./ Esta declaración de conformidad se emite bajo la única responsabilidad del fabricante./ Questa dichiarazione di conformità è rilasciata sotto la sola responsabilità del produttore./ Esta declaração de conformidade é emitida sob a exclusiva responsabilidade do fabricante./ Niniejsza deklaracja zgodności została wydana na wyłączną odpowiedzialność producenta./ Deze verklaring van overeenstemming wordt afgegeven onder de uitsluitende verantwoordelijkheid van de fabrikant./ Toto prohlášení o shodě je vydáno na výhradní odpovědnost výrobce./ Denna försäkran om överensstämmelse utfärdas på tillverkarens eget ansvar. / Denne overensstemmelseserklæring er udstedt på producentens eget ansvar./ Tämä vaatimustenmukaisuusvakuutus annetaan valmistajan yksinomaisella vastuulla./ Käesolev vastavusdeklaratsioon on välja antud tootja ainuvastutusel./ Šī atbilstības deklarācija ir izdota uz ražotāja atbildību./ Už šią atitikties deklaraciją atsako tik gamintojas./ Настоящата декларация за съответствие се издава на пълната отговорност на производителя./ Ezt a megfelelőségi nyilatkozatot a gyártó kizárólagos felelősége mellett adjuk ki./ Prezenta declarație de conformitate este emisă pe răspunderea exclusivă a producătorului./ Η παρούσα δήλωση συμμόρφωσης εκδίδεται με αποκλειστική ευθύνη του κατασκευαστή./ Ova izjava o skladnosti izdaje se isključivo pod odgovornošću proizvođača./ Toto vyhlásenie o zhode sa vydáva na výhradnú zodpovednosť výrobcu./ Za to izjavo o skladnosti je odgovoren izključno proizvajalec./ Din izdelkarazjoni ta' konformità għandha tinfhaqg taħt ir-responsabbiltà unika tal-manifattur./ Данная декларация соответствия выдана под исключительную ответственность производителя./ この適合宣言は、製造者の単独責任のもとで発行されています。/本符合性声明由制造商全权负责发布。</p>

## SAMES

Siège Social / Headquarter: 13, chemin de Malcher - CS70086 - 38243 Meylan Cedex - France - Tél / Phone: +33 (0)4 76 41 60 60  
 SAS au capital de 12.720.000 euros | RCS Grenoble: 572 051 688 | Code APE: 2829B | TVA intracom: FR36 572051688  
[info@sames.com](mailto:info@sames.com) - [www.sames.com](http://www.sames.com) | Société d'EXEL Industries / EXEL Industries company



## UK DECLARATION OF CONFORMITY

(1) The manufacturer herewith declares that the equipment is in conformity with the relevant Union harmonization legislation.

<b>(2) Equipment type</b>	PULVERISATEUR ELECTROSTATIQUE DE PEINTURE / ELECTROSTATIC PAINT SPRAY SYSTEM			
	<b>Nanogun+ Airspray / GNM 6080</b>			
<b>(3) Applicable Directives</b>	2016 No. 1107	<b>(4) Marking</b>	Sprayer Nanogun+ Airspray II 2 G 0.24 mJ	
			Control module GNM 6080 II (2) G [0.24 mJ]	
		Matériel associé GNM 6080 doit être installé en zone sûre (zone non dangereuse) Associated equipment GNM 6080 must be installed in safe zone (non explosive area)		
	2016 No. 1091	<b>(5) Designated standards</b>	EN 50050-1 : 2013	
		<b>(6) Conformity assessment procedures</b>	UK type examination certificate : CML 21UKEX9793	Approved Body 2503 : Eurofins E&E CML Limited
	Production Quality Assurance Notification : CML 21UKQAN14372		Newport Business Park, New Port Road Ellesmere Port CH65 4LZ UK	
2016 No. 1101	<b>(5) Designated standards</b>	EN 61000-6-4 : 2007 /A1 : 2011 EN 61000-6-2 : 2005		
2016 No. 1101	<b>(5) Designated standards</b>	EN 61010-1 : 2011		
<b>(7) This declaration of conformity is issued under the sole responsibility of the manufacturer.</b>				

**Director of the MEYLAN site - Executive Management (EM)**

Richard WLODARCZYK

DocuSigned by:

*Richard Wlodarczyk*

9900D9C0034B4A2...

Established in Meylan, on 27-mars-23 | 18:26 CEST

SAMES

Siège Social / Headquarter: 13, chemin de Malacher - CS70086 - 38243 Meylan Cedex - France - Tél / Phone: +33 (0)4 76 41 60 60  
SAS au capital de 12.720.000 euros | RCS Grenoble: 572 051 688 | Code APE: 2829B | TVA intracom: FR36 572051688  
[info@sames.com](mailto:info@sames.com) - [www.sames.com](http://www.sames.com) | Société d'EXEL Industries / EXEL Industries company



## UK DECLARATION OF CONFORMITY

(1)	<p>Le Fabricant déclare que le matériel désigné ci-après est conforme à la législation d'harmonisation de l'Union applicable suivante/ Der Hersteller erklärt, dass das nachfolgend bezeichnete Material den folgenden anwendbaren Harmonisierungsrechtsvorschriften der Union entspricht / El fabricante declara que el equipo designado a continuación es conforme con la siguiente legislación de armonización de la UE aplicable / Il fabbricante dichiara che l'attrezzatura designata di seguito è conforme alla seguente legislazione di armonizzazione UE applicabile / O Fabricante declara que o equipamento designado abaixo está em conformidade com a seguinte legislação de harmonização aplicável da UE / Producent deklaruje, że urządzenie wskazane poniżej jest zgodne z następującymi obowiązującymi przepisami harmonizacyjnymi UE/ De fabrikant verklaart dat de hieronder beschreven apparatuur in overeenstemming is met de volgende toepasselijke EU-harmonisatiewetgeving/ Výrobce prohlašuje, že níže uvedené zařízení je ve shodě s těmito platnými harmonizačními právními předpisy EU/ Výrobce prohlašuje, že níže uvedené zařízení je ve shodě s těmito platnými harmonizačními právními předpisy EU/ Producenten erklærer, at det nedenfor angivne udstyr er i overensstemmelse med følgende gældende EU-harmoniseringslovgivning/ Valmistaja vakuuttaa, että jäljempänä mainitut laitteet ovat seuraavien sovellettävien EU:n yhdenmukaistamislainsäädäntöjen mukaisia./ Tootja kinnitab, et allpool nimetatud seadmed vastavad järgmistele kohaldatavatele ELi ühtlustamise õigusaktidele./ Ražotājs apliecina, ka turpmāk norādītās iekārtas atbilst šādiem piemērojamiem ES saskaņošanas tiesību aktiem./ Gamintojas pareiškia, kad toliau nurodyta įranga atitinka šiuos taikytinus ES derinamuosius teisės aktus/ Производителят декларира, че посоченото по-долу оборудване е в съответствие със следното приложимо законодателство на ЕС за хармонизация/ A gyártó kijelenti, hogy az alább megjelölt berendezés megfelel a következő alkalmazandó uniós harmonizációs jogszabályoknak / Producătorul declară că echipamentul desemnat mai jos este în conformitate cu următoarea legislație de armonizare a UE aplicabilă / Ο κατασκευαστής δηλώνει ότι ο εξοπλισμός που αναφέρεται κατωτέρω συμμορφώνεται με την ακόλουθη ισχύουσα νομοθεσία ενωμοσύνης της ΕΕ/ Προϊζοδαč ovlme izjavljuje da je oprema u skladu sa zakonskim zahtjevima Uje dinjene Kraljevine./ Výrobca vyhlasuje, že níže uvedené zariadenie je v súlade s týmito platnými harmonizačnými právnymi predpismi EÚ/ Произвојалец изјавља, да је сподј наведена опрема складна з наследњо велјавно усклајевално законодојо EU/ Производител заявяет, что указанное ниже оборудование соответствует следующим применимым законодательным актам ЕС по гармонизации/ 製造者は、以下に指定された装置が、適用される以下のEU調和法に適合していることを宣言する。/ 製造商声明, 下面指定的设备符合以下适用的欧盟协调立法。</p>
(2)	<p>Type d'équipement/ Art der Ausrüstung/ Tipo de equipo/ Tipo di attrezzatura/ Tipo de equipamento/ Rodzaj sprzętu/ Type uitrusting/ Typ zařízení/ Typ av anordning/ Type af anordning/ Laitteen tyyppi/ Seadme tüüp/ Iekārtas tips/ Įrangos tipas/ Вид оборудване/ A berendezés típusa/ Tipul de echipament/ Τύπος εξοπλισμού/ Vrsta opreme/ Typ zariadenia/ Vrsta naprave/ Тип оборудования/ 機器の種類/ 设备类型</p>
(3)	<p>Directives applicables/Anwendbare Richtlinien/Directivas aplicables/Direttive applicabili/Directivas aplicáveis/Obowiązujące dyrektywy/Toepasselijke richtlijnen/Platné smernice/ Tillämpiga direktiv/ Gældende direktiver/ Sovellettavat direktiivit/ Kohaldatavad direktiivid/ Piemērojams direktīvas/ Taikomas direktyvos/ Приложими директиви/ Alkalmazandó irányelvek/ Directive aplicabile/ Ισχύουσες οδηγίες/ Primjenjive smjernice/ Uplatnitelne smernice/ Veljavne directive/ Применимые директивы/ 適用される指令/ 适用的指令</p>
(4)	<p>Marquage/ Markierung/ Marcado/ Marcatura/ Marcação/ Znakovanie/ Marketing/ Označení/ Märkning/ Märkning/ Merkintä/ Märgistus/ Marķējums/ Ženkinimas/ Маркировка/ Jelölés/ Marcare/ Ίσημηση/ Obilježava/ Označovanie / Označevanje/ Маркировка/ マーキング/ 标识</p>
(5)	<p>Normes désignées/ Bezeichnete Normen/ Normas designadas/ Norme designate/ Normas designadas/ Normy wyznaczone/ Aangewezen normen/ Určené normy/ Utpekade standarder/ Udpegede standarder/ Nimetyl standardit/ Määratud standardid/ Izraudzītie standarti/ Paskirtieji standarti/ Определени стандарти/ Kijelölt szabványok/ Standarde desemnate/ Καθορισμένα πρότυπα/ Određeni standardi/ Určené normy/ Določeni standardi/ Назначенные стандарты/ 指定された規格/ 指定的标准</p>
(6)	<p>Procédure d'évaluation de la conformité/ Verfahren der Konformitätsbewertung/ Procedimiento de evaluación de la conformidad/ Procedura di valutazione della conformità/ Procedimento de avaliação da conformidade/ Procedura oceny zgodności/ Conformiteitsbeoordelingsprocedure/ Postup posuzování shody/ Förfarande för bedömning av överensstämmelse/ Procedure for överensstemmelsesvurdering/ Vaatimustenmukaisuuden arviointimenettely/ Vastavushindamismenetlus/ Atbilstības novērtēšanas procedūra/ Atitikties vertinimo procedūra/ Процедура за оценка на съответствието/ Megfelelőségértékelési eljárás/ Procedura de evaluare a conformității/ Διαδικασία αξιολόγησης της συμμόρφωσης/ Postupak ocjene usklađenosti/ Postup posuzovania zhody/ Postopek ugotavljanja skladnosti/ Процедура оценки соответствия/ 適合性評價手順/ 適合性評估程序</p>
(7)	<p>Cette déclaration de conformité est délivrée sous la seule responsabilité du fabricant. / Diese Konformitätserklärung wird unter der alleinigen Verantwortung des Herstellers ausgestellt./ Esta declaración de conformidad se emite bajo la única responsabilidad del fabricante./ Questa dichiarazione di conformità è rilasciata sotto la sola responsabilità del produttore./ Esta declaração de conformidade é emitida sob a exclusiva responsabilidade do fabricante./ Niniejsza deklaracja zgodności została wydana na wyłączną odpowiedzialność producenta./ Deze verklaring van overeenstemming wordt afgegeven onder de uitsluitende verantwoordelijkheid van de fabrikant./ Toto prohlášení o shodě je vydáno na výhradní odpovědnost výrobce./ Denna försäkrän om överensstämmelse utfärdas på tillverkarens eget ansvar. / Denne overensstemmelseserklæring er udstedt på producentens eget ansvar./ Tämä vaatimustenmukaisuusvakuutus annetaan valmistajan yksinomaisella vastuulla./ Käesolev vastavusdeklaratsioon on välja antud tootja ainuvastutusel./ Šī atbilstības deklarācija ir izdota uz ražotāja atbildību./ Už šīs atitikties deklarācijai atsako tik gamintojas./ Настоящата декларация за съответствие се издава на пълната отговорност на производителя./ Ezt a megfelelőségi nyilatkozatot a gyártó kizárólagos felelősége mellett adjuk ki./ Prezenta declaratie de conformitate este emisă pe răspunderea exclusivă a producătorului./ Η παρούσα δήλωση συμμόρφωσης εκδίδεται με αποκλειστική ευθύνη του κατασκευαστή./ Ova izjava o skladnosti izdaje se isključivo pod odgovornošću proizvođača./ Toito vyhlásenie o zhode sa vydáva na výhradnú zodpovednosť výrobcu./ Za to izjavno o skladnosti je odgovoren izključno proizvajalec./ Din iddikjarazzjoni ta' konformità għandha tinhaieg taht ir-responsabbiltà unika tal-manifattur./ Данная декларация соответствия выдана под исключительную ответственность производителя./ この適合宣言は、製造者の単独責任のもとで発行されています。/ 本符合性声明由制造商全权负责发布。</p>

## SAMES

Siège Social / Headquarter: 13, chemin de Malcher - CS70086 - 38243 Meylan Cedex - France - Tél / Phone: +33 (0)4 76 41 60 60  
 SAS au capital de 12.720.000 euros | RCS Grenoble: 572 051 688 | Code APE: 2829B | TVA intracom: FR36 572051688  
[info@sames.com](mailto:info@sames.com) - [www.sames.com](http://www.sames.com) | Société d'EXEL Industries / EXEL Industries company