

FStart Pressure / Suction



135756312 Gun FStart P Compliant HVLP-12-XLva
135756315 Gun FStart P Compliant HVLP-15-XLva
135756318 Gun FStart P Compliant HVLP-18-XLva
135756412 Gun FStart P CONV-12-XLva
135756415 Gun FStart P CONV-15-XLva
135756418 Gun FStart P CONV-18-XLva
135756712 Gun FStart P Compliant LVLP-12-XLva
135756713 Gun FStart P Compliant LVLP-13-XLva
135756715 Gun FStart P Compliant LVLP-15-XLva
135756718 Gun FStart P Compliant LVLP-18-XLva

135756515 Gun FStart S CONV-15-Mva
135756518 Gun FStart S CONV-18-Mva



II 2G Ex h IIB T6 Gb X

Translation from the original manual - Index C
582120110-US

SAMES KREMLIN SAS
13 Chemin de Malacher
38240 Meylan
Tél.: 33 (0)4 76 41 60 60
www.sames-kremlin.com

1	Table of contents	
2	Safety	3
3	Declaration	7
4	Identification of the product.....	7
4.1	Description of FStart Pressure / Suction.....	7
4.2	Description of the ATEX / UKCA marking.....	7
5	Technical data	9
5.1	FStart Pressure / Suction materials	10
5.2	Air and fluid connections.....	10
5.3	Nozzle characterization principle	10
6	Installation.....	11
6.1	General installation diagram	11
6.2	Installation diagram - Air pressure adjustment with or without gauge at the gun handle	12
7	Storage.....	13
8	Start-up.....	13
9	Adjustments.....	13
10	Gun handling	14
11	Maintenance	15
11.1	Preventive maintenance	15
12	Assembly - Disassembly	15
13	Assembly errors	16
14	Troubleshooting	16
15	FStart Pressure / Suction commercial references.....	18
15.1	Available projectors – references P/Ns.....	20
15.2	Available accessory – references P/Ns	21
15.3	Available packages – references P/Ns	21
16	Maintenance kit 129.756.902.....	22
16.1	Visual diagrams	22
16.2	Parts list and FStart Pressure / Suction maintenance kit (spare parts)	23
17	Dimensions FStart Pressure / Suction.....	24
18	Warranty	25



Any communication or reproduction of this document, in any form whatsoever, and any exploitation or communications of its contents are prohibited, except with the express written permission of



SAMES KREMLIN.

The descriptions and characteristics contained in this document are subject to change without prior notice.

© **SAMES KREMLIN 2020**

2 Safety





Prerequisite	<ul style="list-style-type: none"> •  The present equipment is for professional use only. It must be used only for its intended purpose. • Read the specified recommendations carefully : <ul style="list-style-type: none"> - In the technical manuals of the equipment concerned. - On device labels. • Misuse or improper operation can cause serious injury.
Operator training and certification	<ul style="list-style-type: none"> • Personnel using this equipment must be trained in its use. • The workshop managed must ensure that the operation fully understand all instructions and safety rules for this equipment and the other components and accessories of the installation. • Furthermore, only authorized personnel should be allowed to carry out production and maintenance operations on the equipment.
Operators safety	<ul style="list-style-type: none"> •  These parts of PPE (Personal Protective Equipment) are mandatory due to the risk of this process. • Avoid abnormal postures and maintain a stable position in order to keep your balance at all times, to better control the equipment in the event of an unexpected event. • Make sure that the workstation is neat and clean. Scattered or piled up parts and tools are a source of an accident.
Products, paints	<ul style="list-style-type: none"> •  It is forbidden to use material containing high concentrations of halogenated hydrocarbon solvents with aluminium or zinc fillers. • Non-compliance with the instructions may cause explosion risk causing serious or fatal injury. • The user shall identify and prevent potential hazards inherent in the fluids used, such as fire or explosion hazards, and toxicity hazards with serious injuries through contact with the body, in the eyes, under the skin, or through ingestion or inhalation. • With regard to the fluids and paints used with its equipment, SAMES KREMLIN cannot be held responsible for direct or indirect material damage caused in use, for the poor compatibility of the materials in contact, for the inherent risks to personnel and the environment, for wear and tear, for malfunctions of the equipment or installations and for the quality of the finished product.

<p>Ventilation</p>	<ul style="list-style-type: none">  <p>It is imperative that the spray booths are properly ventilated to prevent any high concentration of fluid or paint and maintain it lower than the LEL (Lower Explosion Limit).</p> <p>If ventilation is shut off, toxic substances or contamination may remain in the spray booth and cause a risk of fire, poisoning or irritation.</p>
<p>Toxicity</p>	<ul style="list-style-type: none">  <p>Depending on the fluid used, toxic and/or flammable vapors may form.</p> <p>There is a danger of intoxication and burning due to the concentration of these vapors.</p>
<p>Risk fire, explosion, electric arc</p>	<ul style="list-style-type: none">  <p>Applicable laws and regulations regarding safety, fire and electricity in the country where the equipment is used must be complied with.</p> <p>The gun must be used in the areas for which it has been validated. Refer to the ATEX section of the document.</p>

Grounding



- In order to prevent the accumulation of electrostatic charges which could generate an electric arc in a flammable or explosive environment, it is necessary that all conductive components of the system are grounded.
- The gun must be 'grounded' via the fluid hose or the air hose.
- The equipment to be painted must also be 'grounded' by means of clamps fitted with cables or, if suspended, by means of hooks which must be kept clean at all times.
- Follow the shutdown procedure and always depressurize air and fluid circuits before carrying out any servicing on the gun (cleaning checking, maintenance of the fluid or cleaning of the gun nozzles).
- This gun is a precision tool. Its proper operation requires frequent and careful maintenance.
- If it is carried out immediately after work, cleaning is easier and quicker.
- Never use wire brushes, files or pliers for disassembly.
- Before cleaning or disassembling any component of the equipment, it is imperative:
 - to stop the pump by cutting off the compressed air supply,
 - to decompress the hoses by pulling the trigger.
- Never store more than necessary inflammable materials inside the working area.
- These materials must be stored in approved drums and grounded.
- Use only grounded metals containers for cleaning solvents.
- Cardboard and paper are prohibited.
- The tanks of fluids and cleaners must be grounded via a grounding cable, either by means of clamps or some other means of attachment.
- The parts to be painted are hung or placed by means of hooks or supports which are grounded and kept clean at all times, in order to always guarantee good conductivity to ground.
- All insulation (cardboard, paper, plastic materials) must be kept to a minimum in the work area.
- The ground continuity must be checked by a qualified technician.
- Never operate the equipment without ensuring that all the above safety requirements are met.

Pressure	<ul style="list-style-type: none"> •  The use of pressurized air and fluids (paints or solvents) presents risks for the user and the equipment. • Never exceed the maximum working pressures of the equipment, components and accessories. • For all cleaning, inspection and maintenance operations on the equipment, it is imperative to follow the procedures for decompression, shutdown, locking of any residual pressure, elimination of residual static electricity charges and purging of fluids
Surfaces, edges, corners	<ul style="list-style-type: none"> •  Some component surfaces may be hot during operation. Skin contact with hot surfaces causes severe skin burns. •  Handle open or sharp-edged components with care. Wear protective gloves.
Equipment modification	<ul style="list-style-type: none"> • Under no circumstances should this equipment be modified or used for purposes not intended. • Parts and accessories must only be supplied or approved by SAMES KREMLIN. • SAMES KREMLIN cannot be held responsible for personal injury as well as breakdowns and/or damage resulting from modifications to the equipment. • Any modification of equipment made by the user and not authorized by SAMES KREMLIN will result in loss of certification.
Environment	<ul style="list-style-type: none"> • Environmental risks must be controlled as follows: <ul style="list-style-type: none"> - Respect an average temperature of use of the equipment and products, which must be at least 5°C (41°F), lower than the flash point of the products and within a range of 0 to 40°C (32° to 104° F). - Ventilation of the area by forced extraction and supply of unpolluted air is mandatory during operation of the equipment and cleaning operations. - Fragile parts of the installation, especially the flexible hoses, must be protected from mechanical or thermal damage during production or maintenance. - Wastes related to the operation or dismantling of the equipment must be treated in accordance with the applicable laws. •  The noise level of our equipment is limited to a maximum. However, operators must be protected according to the overall noise level of the environment. Depending on the operating conditions, the sound volume of the equipment may cause hearing problems. Use hearing protection and take appropriate measures to reduce noise pollution. • Dispose of packaging materials in an appropriate and environmentally friendly manner.

3 Declaration

Refer to the declaration delivered with the equipment.

4 Identification of the product

4.1 Description of FStart Pressure / Suction



Guns recommended to spray varnishes, lacquers, shades, polyurethanes.

4.2 Description of the ATEX / UKCA marking

- Each device is marked with the name of the manufacturer, the reference of the device and important information for the use of the device (air pressure, electrical power, etc.).
- These equipments have been designed in accordance with the ATEX Directive 2014/34/EU and its intended for use in Zone 1.

PMS 6bar
 MWP 87psi
 P air 6bar
 P air 87psi



Description	
SAMES KREMLIN logo	Manufacturer trademark
FStart Pressure / Suction	Gun model
CE	CE : European conformity
	 : For use in explosive area II : group II 2 : class 2 Surface equipment meant to an area where explosive atmospheres due to gas, vapours, mists are liable to appear from time to time in usual operating. G : gas
Ex h IIB T6	Ex : Marking of conformity with European standards h : Mode of protection for non-electrical device IIB : Reference gas for equipment qualification T6 : Temperature class - Maximum surface temperature : 85°C / 185°F*
Gb	Gb : Equipment protection level (Gas zone 1)
X	X : Special conditions that apply for a safe use. Refer to instructions listed in the instruction manuals accompanying your purchase.
20xx	Marking of the manufacturer year (with 4 characters)
UKCA	UK CA : UK Conformity Assessment Marking required for certain products placed on the market in the UK
PMS 6 bar / MWP 87 psi	Maximum fluid pressure
P air 6 bar / 87 psi	Gun air supply maximum pressure

* Temperature class

Temperature class	Maximum surface temperature
T6	85° C / 185° F

5 Technical data

	FSTART P CONV	FSTART P HVLP	FSTART P LVLP	FSTART S CONV
Version	Pressure			Suction
Maximum air supply pressure (network)	6 bar / 87 psi			
Maximum fluid supply pressure	6 bar / 87 psi			
Product supply	M 3/8 NPS			
Air flow rate	22.1m ³ /h	19.4m ³ /h	23m ³ /h	21.3m ³ /h
Air pressure at the gun handle	3 bar / 43.5 psi	2.2 bar / 31.9 psi	2.5 bar / 36.3 psi	3 bar / 43.5 psi
Weight with cup				739 g
Weight without cup	402 g	401 g	402 g	402 g
Version	85 dBA	80.1 dBA	84 dBA	83.9 dBA

5.1 FStart Pressure / Suction materials

Gun body	Chrome die-cast aluminum
Aircap	Clear anodized aluminium
Nozzle	INOX (Stainless steel)
Needle	INOX (Stainless steel)
Suction cup	Aluminium

5.2 Air and fluid connections

Gun	Fittings mounted on the gun (depending on model)	Air and fluid supply
Air	Male 1/4 NPS	Air hose (anti-static quality) HVLP / LVLP : minimum Ø 8 mm ID (for a 7.5 m / 24.6 ft length) CONV : minimum Ø 7 mm ID (for a 7.5 m / 24.6 ft length)
Fluid	Male 3/8 NPS	For pressure gun (HVLP, LVLP and CONV) Fluid hose : minimum Ø 7 mm ID (for a 7.5 m / 24.6 ft length)
	Suction cup	Suction cup (1 liter)

5.3 Nozzle characterization principle

Nozzle parameter	
Technology	Nozzle size
H : HVLP L : LVLP C : CONVENTIONAL	<ul style="list-style-type: none"> • 12 : 1.2 mm • 13 : 1.3 mm • 15 : 1.5 mm • 18 : 1.8 mm

6 Installation

6.1 General installation diagram

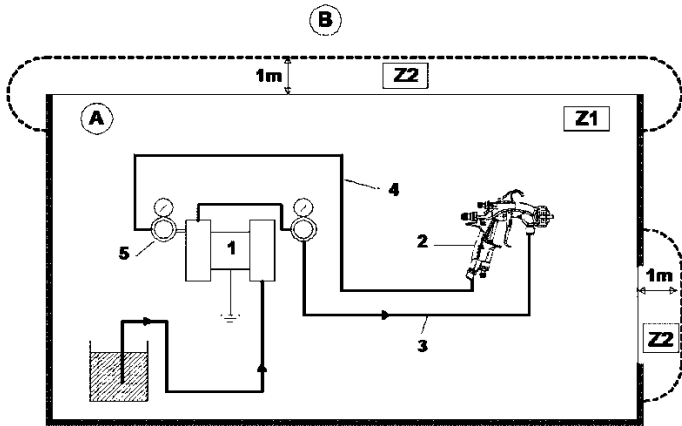

A- Explosive area Area 1 (Z1) or Area 2 (Z2) : spraybooth	B - Non-explosive area	1 - Pump	2 - Airspray gun	3 - Fluid hose	4 - Antistatic air hose	5 - Air regulator
---	------------------------	----------	------------------	----------------	-------------------------	-------------------



The 1 m / 39.37" distance indicated in the diagram is given for information purposes only and hold harmless to **SAMES KREMLIN**. The user is responsible for the extracion and conditioning of the painting area where the equipment is used, for working conditions.

The 1 m / 39.37" distance may be modified if trials carried out by the user deem this necessary.

- Using the grounding air hose, connect the gun to an air regulator that can supply at least 3 bar / 43.5 psi.
- Using the fluid hose, connect the gun fluid fitting to the pump. Tighten the fittings firmly.

Note: *In some particulars cases, if the air hose (4) is not conductive, the fluid hose (3) must be conductive. One of the 2 gun hoses (air or fluid) must be conductive.*

6.2 Installation diagram - Air pressure adjustment with or without gauge at the gun handle

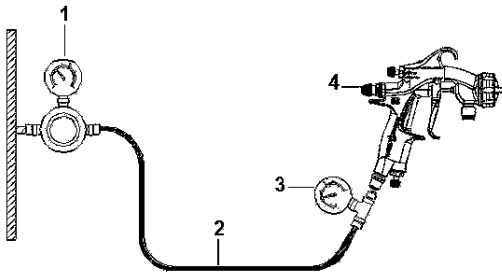

3 - P 1 : Pressure measured at the gun handle during the operating (air needles open)	4 – Guns, models FStart Pressure - Suction
---	--

1 - P 0 : Pressure	2 - Air hose
--------------------	--------------

7 Storage

Our equipment must be stored in its original packaging.

In case of prolonged storage, it is preferable to carry out preventive maintenance for all lubricants before start-up.

Storage before installation

- Storage ambient temperature 0 / +50 °C (32° F / 122° F).
- Protect the complete unit from dust/dirt, water/condensation, moisture, vibration and shock.
- Do not remove the packaging until just before assembly.

Storage after installation

- Protect the unit from dust/dirt, water/condensation, moisture and shock.

8 Start-up

- Assemble the aircap on the gun by positioning it according to the desired spray orientation.
- Open at the maximum the air needles.
- Open the fluid needle as far as it will go  without a stop.
- Connect the air hose.
- Assemble the cup or connect the fluid hose.
- Pull the trigger and check that the air is circulating normally.

9 Adjustments

This professional spray gun features 3 controls :

Spraying fineness

- Air is fed by the central air. The air is adjusted by means of the air regulator mounted upstream of the gun on the network and more precisely by means of the knob at the bottom of the gun handle on some manual guns.

Fan width

- Fan width is adjusted by using the knurled knob. It controls the air going to the horns on the aircap. In this way, the air is controlled through the fanned air outlets and allows the fan to change from flat (wide open) to round (closed).

Fluid output

- Having selected the proper fluid nozzle / needle assembly and the fluid pressure, it is possible to:
- Further control the output by changing the travel of the needle (using the needle stop knob).
- Optimal set up is usually obtained when the fluid needle is completely open. When this needle is nearly closed, a constant flow of fluid cannot be guaranteed.

10 Gun handling

When assembling the aircap on the gun, hold it vertically in order to correctly align the aircap before screwing the aircap ring.

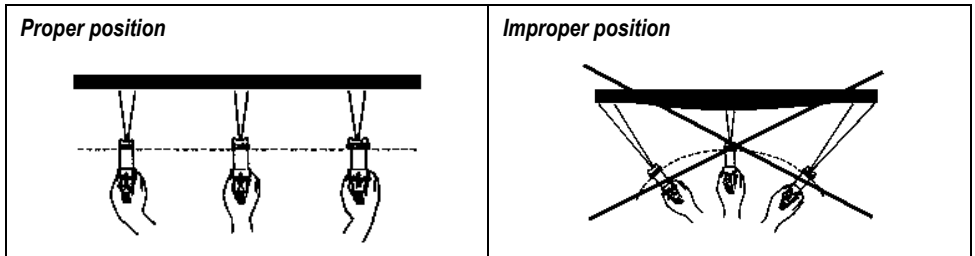

- Keep the gun perpendicular to the surface to be painted.
- Avoid working with the wrist.
- Do not forget that crossed sweeps cannot correct irregularities. Spraying from a stationary gun will not give you even coverage.
- Start the pass and trigger just before the leading edge. Release the trigger before the pass ends, just after the trailing edge of the object.
- Make sure that overlapping from the passes is even.

11 Maintenance

11.1 Preventive maintenance

Daily

- Check groundings.
- Clean the outside of the spray nozzle with a soft brush and solvent.
- Flush the spray gun.
- When the spraying system will not be used for an extended period of time, take off the nozzle and immerse it in a solvent filled container.

Weekly

- Check leakage from the fittings

Monthly

- Check hoses.
- Operate the valves.
- Remove the air valve, clean it if necessary. Grease it as well as the spring before assembling.
- Remove the needle as well as the rear line and the complete air valve.
- Clean the parts and grease them before assembling.

Annual

- Change the air valve. Grease the air valve as well as the spring, before assembling.
- Remove the gun.
- Clean the parts.
- Change the seals and any defective parts.
- Grease them before assembling (refer to seal and servicing kits).

Note: Frequencies are given as an estimate. They must be adapted by the maintenance service of the user for every installation depending on the fluid, the workload and the working pressure.

12 Assembly - Disassembly

Before removing a component of the gun, some precautions have to be taken:

- Shut off the fluid pressure,
- Empty out the paint inside the cup or the receiver and clean it,
- Fill the cup or the receiver with cleaning solvent,
- Take off the gun spraying air cap,
- Shut off the gun supply air pressure,
- Adjust fluid pressure to 0.5 bar / 7.25 psi and let the solvent circulate,
- Shut off the fluid pressure,
- Remove the part to be cleaned or changed.





Before reassembling the different components, some precautions must be taken:

- Clean all the parts with the appropriate cleaning solvent and a brush.
- Install new seals if it is necessary after having lubricated them with PTFE grease.
- Install new parts if it is necessary.

13 Assembly errors

The use of improper replacement or defective parts may result in hazards to personnel, damage, malfunction or general shutdown of the equipment.

14 Troubleshooting

<p>Distorted spray</p>	<p>Slightly unscrew the aircap retaining ring and rotate the aircap by one half turn. If the defect is reversed, one of the lateral air holes is plugged up or deformed. Clean the gun aircap with solvent and unclog the air holes with compressed air. If the problem is not resolved, it means that the fluid nozzle is damaged.</p>	
<p>Displaced spray</p>	<p>This comes from a defect in the central fan. Clean the aircap and the fluid nozzle. Make sure that:</p> <ul style="list-style-type: none"> • the aircap is correctly centered on the nozzle, • the nozzle is not too big for the needle, • When work is done with a large needle opening and the needle almost closed, the spray pattern is not even in all directions. 	
<p>Fragmented pattern</p>	<p>The fan air pressure is too high at the holes in the air cap horns:</p> <ul style="list-style-type: none"> • turn the fan air control clockwise to reduce the fan air pressure, • increase the paint output. 	
<p>Fan too thick in the center</p>	<p>This is the reverse of the above defect:</p> <ul style="list-style-type: none"> • the paint output is too high for the selected air pressure : • increase the spraying air pressure and reduce the paint output. • if the paint is too thick, dilute it. 	
<p>Intermittent spray pattern</p>	<p>An air inlet in the paint circuit creates an intermittent pattern when:</p> <ul style="list-style-type: none"> • the paint cup is nearly empty, • when the nozzle is not tightened on its seat: clamp it. <p>If the problem persists, remove the nozzle and clean it.</p> <ul style="list-style-type: none"> • Check that the seat and the cone are not damaged, remove the nozzle and clamp it. • Check that: the cup cover air hole is not blocked and the paint is homogeneous and fluid enough (use the viscosity cup). • Check that the 'pressure' gun is not being used with a 'suction' cup. 	

Trouble	Cause	Solution
No fluid out of the gun	<ul style="list-style-type: none"> • Clogged nozzle 	<ul style="list-style-type: none"> • Cut the pressure on the pump. Depressurize the hoses. • Remove and clean the nozzle with solvent by means of the brush. • Check the seal condition.
Pattern width narrows during reversing phase of the pump	<ul style="list-style-type: none"> • Air trapped in the fluid circuit 	<ul style="list-style-type: none"> • Check connections and suction hose quality.
	<ul style="list-style-type: none"> • Viscosity too high 	<ul style="list-style-type: none"> • Reduce viscosity.
Aircap becomes dirty frequently	<ul style="list-style-type: none"> • Too much atomizing air 	<ul style="list-style-type: none"> • Reduce air pressure.
Fluid seeping from the air holes of the aircap	<ul style="list-style-type: none"> • Defective nozzle seal 	<ul style="list-style-type: none"> • Replace it.
	<ul style="list-style-type: none"> • Nozzle loose 	<ul style="list-style-type: none"> • Tighten it.
Fluid leak at the packing	<ul style="list-style-type: none"> • Packing is worn 	<ul style="list-style-type: none"> • Tighten up the packing holder without blocking the needle.
		<ul style="list-style-type: none"> • If there is still a leak, replace the packing and the needle.
Fluid leak at the front part of the gun, trigger released	<ul style="list-style-type: none"> • Impurities in the paint 	<ul style="list-style-type: none"> • Trigger the gun 3 or 4 times.
	<ul style="list-style-type: none"> • Needle worn or/and nozzle worn 	<ul style="list-style-type: none"> • Replace needle or/and nozzle.
Air leak at the valve	<ul style="list-style-type: none"> • Valve worn 	<ul style="list-style-type: none"> • Change the valve.
Permanent air leak at the gun aircap when the trigger is released	<ul style="list-style-type: none"> • Friction on the needle 	<ul style="list-style-type: none"> • Remove the trigger and check that the needle slides freely.
	<ul style="list-style-type: none"> • Valve worn 	<ul style="list-style-type: none"> • Replace the valve.

15 FStart Pressure / Suction commercial references

Principle of designation

FStart	P	HVLP	-	12	-	XLva
--------	----------	-------------	---	-----------	---	-------------

P=Pressure
S=Suction

HVLP
(High volume, Low pressure)
CONV
(Conventional)
LVLP
(Low volume, Low pressure)

FStart S Conv-15 18-Mva aircap

Nozzle size:

- 12 : 1.2 mm
- 13 : 1.3 mm
- 15 : 1.5 mm
- 18 : 1.8 mm

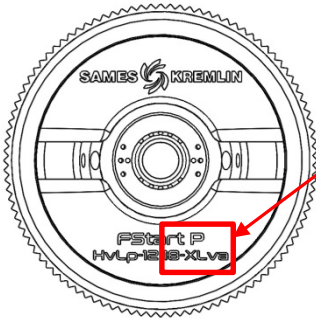

XLva or Mva
Maximum fan width at 20 cm
XL: > 40 cm
M: 20 – 30 cm
Fan shape
v : flat shape
Aircap material
a : Aluminium

FStart Pressure	135756312	Gun FStart P Compliant HVLP-12-XLva
	135756315	Gun FStart P Compliant HVLP-15-XLva
	135756318	Gun FStart P Compliant HVLP-18-XLva
	135756412	Gun FStart P CONV-12-XLva
	135756415	Gun FStart P CONV-15-XLva
	135756418	Gun FStart P CONV-18-XLva
	135756712	Gun FStart P Compliant LVLP-12-XLva
	135756713	Gun FStart P Compliant LVLP-13-XLva
	135756715	Gun FStart P Compliant LVLP-15-XLva
	135756718	Gun FStart P Compliant LVLP-18-XLva
FStart Suction	135756515	Gun FStart S CONV-15-Mva
	135756518	Gun FStart S CONV-18-Mva

15.1 Available projectors – references P/Ns

Projectors FStart Pressure	131756112	Nozzle + Needle FStart HVLP-12
	131756115	Nozzle + Needle FStart HVLP-15
	131756118	Nozzle + Needle FStart HVLP-18
	131756212	Nozzle + Needle FStart CONV-12
	131756215	Nozzle + Needle FStart CONV-15
	131756218	Nozzle + Needle FStart CONV-18
	131756312	Nozzle + Needle FStart LVLP-12
	131756313	Nozzle + Needle FStart LVLP-13
	131756315	Nozzle + Needle FStart LVLP-15
	131756318	Nozzle + Needle FStart LVLP-18
	132756310	Aircap FStart P HVLP-12 18-XLva
	132756410	Aircap FStart P CONV-12-XLva
	132756420	Aircap FStart P CONV-15 18-XLva
	132756710	Aircap FStart P LVLP-12 13-XLva
	132756720	Aircap FStart P LVLP-12 18-XLva
Projectors FStart Suction	131756215	Nozzle + Needle FStart CONV-15
	131756218	Nozzle + Needle FStart CONV-18
	132756510	Aircap FStart S CONV-15 18-Mva

15.2 Available accessory – references P/Ns

Accessory	138400000	Aluminum suction cup	
	138310320	Pack of 10 cup seals and 10 cover seals for suction cup	

15.3 Available packages – references P/Ns

Packages	152756420	Pack Airspray Lucky 2 'FStart P HVLP + Tank 2L'
	152756550	Pack Airspray Lucky 2 'FStart P CONV + Tank 2L'
	152756425	Pack Airspray Lucky 10 'FStart P HVLP + Tank 10L CST'
	152756555	Pack Airspray Lucky 10 'FStart P CONV + Tank 10L CST'

16 Maintenance kit 129.756.902

16.1 Visual diagrams

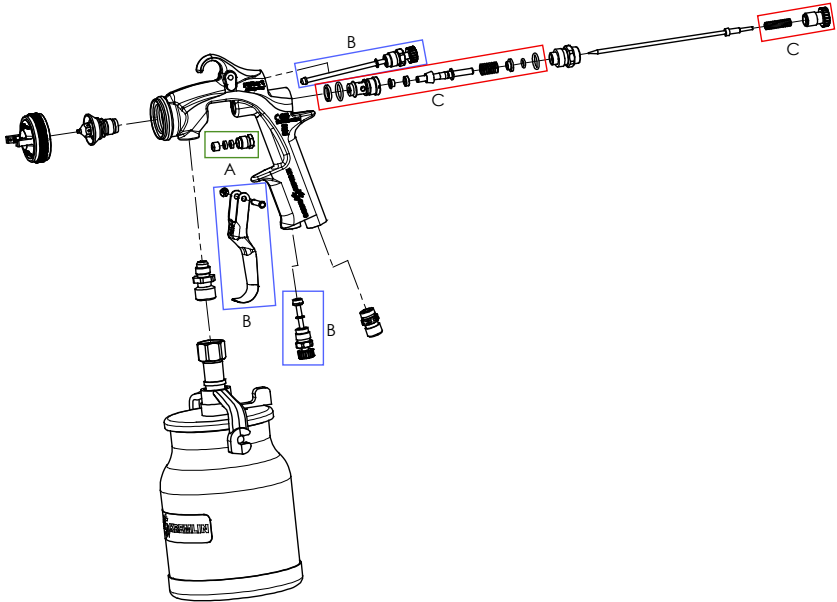
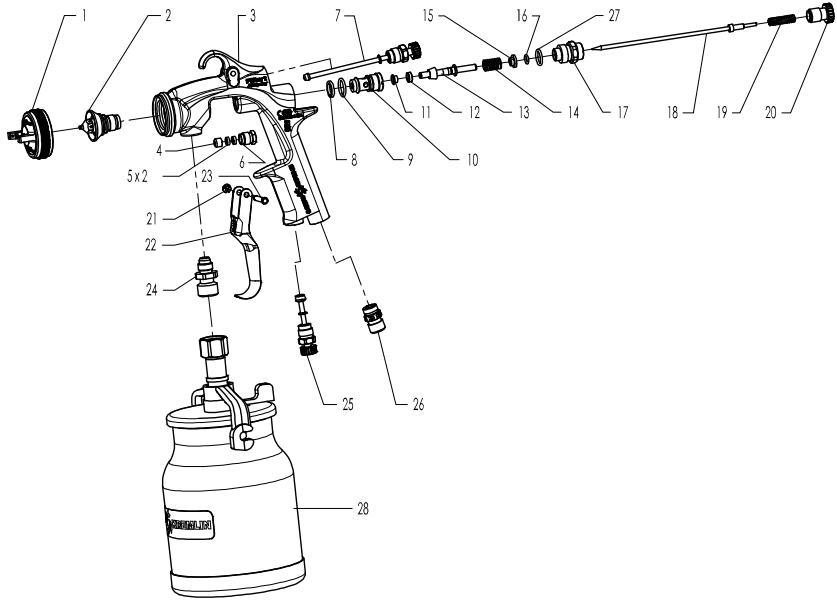

Maintenance kit FStart Pressure / Suction 129.756.902 composed of:		
A	Needle packing	129.756.903
B	Trigger set + air adjusters	129.756.905
C	Rear line assembly	129.756.904

16.2 Parts list and FStart Pressure / Suction maintenance kit (spare parts)

Positions	Designation	Quantity	Included in maintenance kit 129.756.902	
4	Needle packing	1	129.756.903 Needle packing	A
5	Packing gasket	2		
6	Needle packing screw	1		
7	Pattern adjustment valve set	1	129.756.905 Trigger set + air adjusters	B
21	E-ring	1		
22	Trigger	1		
23	Trigger stud	1		
25	Air adjustment valve set	1		
8	Gasket	1	129.756.904 Rear line	C
9	O-ring	1		
10	Sleeve	1		
11	Packing bushing	1		
12	Air valve packing	1		
13	Air valve set	1		
14	Spring	1		
15	Spring seat	1		
16	O-ring	1		
19	Spring	1		
20	Fluid adjustment screw	1		
27	O-ring seal	1		
1	Aircap ring	1		
2	Nozzle	1		
3	Gun body	1		
17	Fluid adjustment seat	1		
18	Needle set	1		
24	Fluid connector	1		
26	Air connector	1		
28	Cup	1		

Accessory required for assembly / disassembly

Designation	Visual
Wrench delivered with the FStart Pressure / Suction guns	

17 Dimensions FStart Pressure / Suction

Pressure

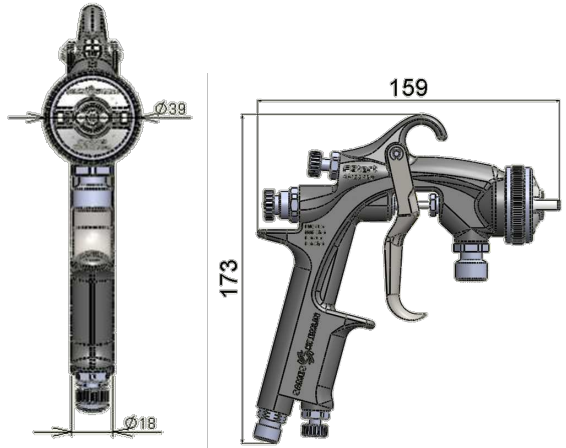

Suction

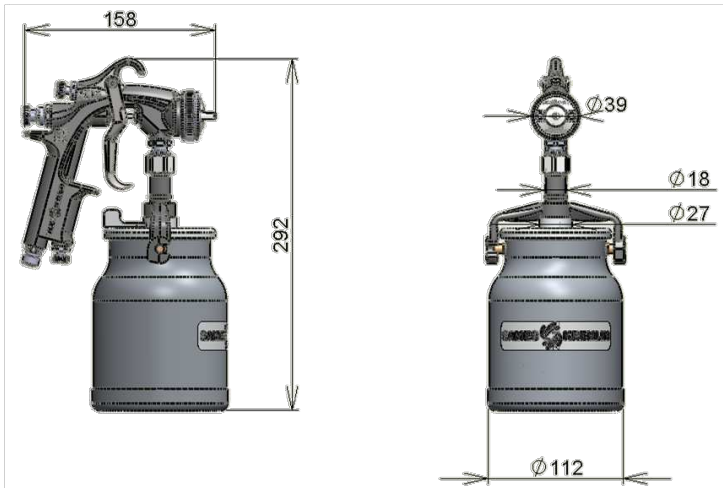

18 Warranty

SAMES KREMLIN grants a contractual guarantee to the customer for a period of twelve (12) months from the notification of supply, subject to compliance with the conditions of use specified in this technical manual.

To be implemented, a written guarantee request must precisely define the malfunction of the item; the defective unit or parts must be sent with the request. Conditions of purchasing by the customer to **SAMES KREMLIN** must also be included of the request.

SAMES KREMLIN will accept or refuse the implementation of the guarantee only after analysis of the 'defective' item. The warranty given by **SAMES KREMLIN** is limited to the replacement of the item in its entirety or the partial replacement of the defective component.

SAMES KREMLIN only bears the cost of the parts needed to replace the defective material.

No guarantee will be granted by **SAMES KREMLIN** for the following:

- For defects and deteriorations resulting from abnormal storage and / or storage conditions at the customer's premises or for maintenance or use of the item that does not comply with the generally accepted procedures or that does not comply with the instructions in this technical manual given to the customer by **SAMES KREMLIN**.
- For defects and damage resulting from replacement parts that were not approved by **SAMES KREMLIN** or that have been modified by the customer,
- For any damage resulting from negligence or a lack of supervision by the customer,
- In case of normal wear of the item and / or its components or in case of deterioration or accident resulting from faulty and / or abnormal use thereof.



<p align="center">FR</p> <p>Pour une utilisation sûre, il est de votre responsabilité de :</p> <ul style="list-style-type: none"> • D'installer, d'utiliser, d'entretenir et de réparer l'équipement conformément aux préconisations de SAMES KREMLIN ainsi qu'aux réglementations nationales et/ou locales, • Vous assurez que les utilisateurs de cet équipement ont été formés, ont parfaitement compris les règles de sécurité et qu'ils les appliquent. 	<p align="center">UK</p> <p>To ensure safe use of the machinery, it is your responsibility to:</p> <ul style="list-style-type: none"> • Install, use, maintain and repair the machinery in accordance with SAMES KREMLIN's recommendations and national and/or local regulations, • Make sure that the users of the machinery have received proper training and that they have perfectly understood the safety rules and apply them. 	<p align="center">DE</p> <p>Eine sichere Nutzung setzt voraus, dass Sie: :</p> <ul style="list-style-type: none"> • die Anlage im Einklang mit den Empfehlungen von SAMES KREMLIN sowie mit den nationalen und/oder lokalen Bestimmungen installieren, verwenden, warten und reparieren, • sich vergewissern, dass die Nutzer dieser Anlage angemessen geschult wurden, die Sicherheitsbestimmungen verstanden haben und sie anwenden.
<p align="center">ES</p> <p>Para una utilización segura, será de su responsabilidad:</p> <ul style="list-style-type: none"> • instalar, utilizar, efectuar el mantenimiento y reparar el equipo con arreglo a las recomendaciones de SAMES KREMLIN y a la normativa nacional y/o local, • cerciorarse de que los usuarios de este equipo han recibido la formación necesaria, han entendido perfectamente las normas de seguridad y las aplican. 	<p align="center">IT</p> <p>Per un uso sicuro, vi invitiamo a:</p> <ul style="list-style-type: none"> • installare, utilizzare, mantenere e riparare l'apparecchio rispettando le raccomandazioni di SAMES KREMLIN, nonché le normative nazionali e/o locali, • accertarsi che gli utilizzatori dell'apparecchio abbiano ricevuto adeguata formazione, abbiano perfettamente compreso le regole di sicurezza e le applichino. 	<p align="center">PT</p> <p>Para uma utilização segura, é da sua responsabilidade:</p> <ul style="list-style-type: none"> • Proceder à instalação, utilização, manutenção e reparação do equipamento de acordo com as preconizações de SAMES KREMLIN, bem como com outros regulamentos nacionais e/ou locais aplicáveis, • Assegurar-se que os utilizadores do equipamento foram devidamente capacitados, compreenderam perfeitamente e aplicam as devidas regras de segurança.
<p align="center">NL</p> <p>Voor een veilig gebruik dient u:</p> <ul style="list-style-type: none"> • het apparaat te installeren, gebruiken, onderhouden en repareren volgens de door SAMES KREMLIN gegeven aanbevelingen en overeenkomstig de nationale en/of plaatselijke reglementeringen, • zeker te stellen dat de gebruikers van dit apparaat zijn opgeleid, de veiligheidsregels perfect hebben begrepen en dat zij die ook toepassen. 	<p align="center">SE</p> <p>För en säker användning av utrustningen ansvarar ni för följande:</p> <ul style="list-style-type: none"> • Installera, använd, underhåll och reparera utrustningen enligt anvisningarna från SAMES KREMLIN och enligt nationella och/eller lokala bestämmelser. • Försäkra er om att användare av denna utrustning erhållit utbildning, till fullo förstått säkerhetsföreskrifterna och tillämpar dem. 	<p align="center">FI</p> <p>Käytön turvallisuuden varmistamiseksi velvollisuutasi on:</p> <ul style="list-style-type: none"> • Noudattaa laitteiston asennuksessa, käytössä, kunnossapidossa ja huollossa SAMES KREMLIN in suosituksia sekä kansallisia ja/tai paikallisia määräyksiä, • Varmistaa, että laitteiston käyttäjät ovat koulutettuja ja ymmärtävät täysin turvallisuusmääräykset ja miten niitä sovelletaan.
<p align="center">PL</p> <p>Dla zapewnienia bezpiecznego użytkowania na użytkownika spoczywa obowiązek:</p> <ul style="list-style-type: none"> • Instalowania, użytkowania, konserwacji i naprawy urządzenia zgodnie z zaleceniami firmy SAMES KREMLIN oraz z przepisami miejscowymi, • Upewnienia, że wszyscy przeszkoleni użytkownicy urządzenia zrozumieli zasady bezpieczeństwa i stosują się do nich. 	<p align="center">CZ</p> <p>Pro bezpečné používání jste povinni:</p> <ul style="list-style-type: none"> • Nainstalovat, používat, udržovat a opravovat zařízení v souladu s pokyny firmy SAMES KREMLIN a s národními a/nebo místními legislativními předpisy, • Ujistit se, že uživatelé tohoto zařízení byli vyškoleni, že dokonale pochopili bezpečnostní pravidla a že je dodržují. 	<p align="center">SI</p> <p>Za varno uporabo ste dolžni:</p> <ul style="list-style-type: none"> • instalirati, uporabljati, vzdrževati in popravljati opremo po določilih SAMES KREMLIN in v skladu z veljavnimi nacionalnimi in/ali lokalnimi predpisi, • poskrbeti, da so uporabniki te opreme ustrezno usposobljeni, poznajo varnostne predpise in da jih upoštevajo.
<p align="center">SK</p> <p>V záujme bezpečného je vašou povinnosťou:</p> <ul style="list-style-type: none"> • nainštalovať, používať, udržiavať a opravovať zariadenie v súlade s odporúčaniami spoločnosti SAMES KREMLIN a národnými a/alebo miestnymi predpismi, • uistiť sa, že používatelia tohto zariadenia boli zaškolení, riadne porozumeli pravidlám bezpečnosti a používajú ich. 	<p align="center">HU</p> <p>A biztonságos használat érdekében az Ön felelőssége hogy:</p> <ul style="list-style-type: none"> • a berendezést a SAMES KREMLIN ajánlásainak valamint a nemzeti és/vagy helyi szabványokhozaknak megfelelően helye zezé üzembe, használja, tartsa karban és javítsa, • megbizonyosodjon róla, hogy a berendezés felhasználói képzettek, tökéletesen megértették és alkalmazzák a biztonsági előírásokat. 	<p align="center">RO</p> <p>Pentru o utilizare sigură, este responsabilitatea dvs. să:</p> <ul style="list-style-type: none"> • Instalați, utilizați, întrețineți și reparați echipamentul conform instrucțiunilor SAMES KREMLIN precum și reglementărilor naționale și/sau locale, • Vă asigurați că utilizatorii acestui echipament au fost instruiți, au înțeles perfect regulile de securitate și le aplică integral.

<p style="text-align: center;">RU</p> <p>Для безопасной эксплуатации вы обязаны :</p> <ul style="list-style-type: none"> Установивайте, эксплуатируйте, обслуживайте и ремонтируйте оборудование в соответствии с инструкциями SAMES KREMLIN и национальными и/или местными нормами, Убедитесь, что пользователи данного оборудования прошли обучение, понимают и соблюдают правила безопасности. 	<p style="text-align: center;">CN</p> <p>为确保设备的安全使用，您有责任：</p> <p>根据 SAMES KREMLIN 的说明以及国家/地区法规 安装、使用、维护/修理设备。</p> <ul style="list-style-type: none"> 确保设备的使用者接受适当的培训，并完全理解安全规则并加以应用。 	<p style="text-align: center;">VN</p> <p>Để sử dụng an toàn, bạn có trách nhiệm:</p> <ul style="list-style-type: none"> Đề lập đặt, sử dụng, bảo trì và sửa chữa thiết bị theo các khuyến nghị của SAMES KREMLIN cũng như các quy định quốc gia và / hoặc địa phương, Đảm bảo rằng người sử dụng thiết bị này đã được đào tạo, hiểu đầy đủ các quy tắc an toàn và họ áp dụng chúng.
<p style="text-align: center;">JP</p> <p>安全に設備を使用するために、以下の点に注意ください。</p> <p>SAMES KREMLIN</p> <p>社の方針および国や地域の規制に従って、機器の設置、操作、保守、修理を行ってください。</p> <ul style="list-style-type: none"> この機器のユーザーガイドレーニングを受け、安全規則を理解し、それに基づいてください。 	<p style="text-align: center;">AR</p> <p>التعميم السلامة عند استخدام الآلات، تقع على عاتق مسؤوليها:</p> <p>SAMES KREMLIN</p> <p>تركب واستخدام وصيانة وإصلاح الآلات وفقاً للوصيات والوائح الوطنية أو المحلية.</p> <ul style="list-style-type: none"> التأكد من تلقي مستخدمى الآلات التدريب اللازم وفهمهم لفتح قواعد السلامة وتطبيق هذه القواعد. 	<p style="text-align: center;">TR</p> <p>Güvenli kullanım için aşağıdakileri yapmak sizin sorumluluğunuzdadır:</p> <ul style="list-style-type: none"> Ekipmanı SAMES KREMLIN tavsiyelerine ve ulusal velveya yerel yönetmeliklere uygun olarak kurmak, kullanmak, bakımını yapmak ve onarmak, Bu ekipmanın kullanıcılarının eğitilmiş olduklarından, güvenlik kurallarını tam olarak anlamadıklarından ve bunları uyguladıklarından emin olun..

Déclaration(s) de conformité au verso de ce document / Declaration(s) of conformity at the back of this document / Konformitätserklärung(en) auf der Rückseite dieser Unterlage / Declaración (es) de conformidad en el reverso de este documento / Dichiarazione/i di conformità sul retro del presente documento / Declaração(ões) de conformidade no verso do documento / Conformiteitsverklaring(en) op de keerzijde van dit document / Försäkrän om överensstämmelse på omstående sida av detta dokument / Vaatimustenmukaisuusvakuutuset tämän asiakirjan kaantöpuolella / Deklaracja(e) zgodności na odwrocie dokumentu / Prohlášení o shodě se nachází/nacházejí na zadní straně tohoto dokumentu / Deklaracija(e) o skladnosti na hrbni strani tega dokumenta / Vyhlásenie/-a o zhode sa nachádzajú na zadnej strane dokumentu / A dokumentum hátlapján szereplő megfelelőségi nyilatkoz(ok) / Declarații de conformitate pe versoul acestui document / Декларация(и) о соответствии на обратной стороне данного документа / 本文件下面の適合性声明 / (Các) tuyên bố về sự phù hợp ở mặt sau của tài liệu này / 本文書の裏面の適合宣言書 / التوافق في الجزء الخلفي لهذا المستند(بينات/بيان) / Bu belgenin arkasındaki uygunluk beyan(lar)

DECLARATION UE DE CONFORMITE
EU DECLARATION OF CONFORMITY
EU-KONFORMITÄTSEKLRÄRUNG
DECLARACIÓN UE DE CONFORMIDAD
DICHIARAZIONE DI CONFORMITÀ UE
DECLARAÇÃO UE DE CONFORMIDADE
EU-KONFORMITEITSVERKLARING
EU-FÖRSÄKRAN OM ÖVERENSSTÄMMELSE
EU-VAATIMUKSENMUKAISUUSVAKUUTUS



DEKLARACJA ZGODNOŚCI UE
EU PROHLÁŠENÍ O SHODĚ
IZJAVA EU O SKLADNOSTI
EÚ VYHLÁŠENIE O ZHODE
EU-MEGFEL ELŐSÉGI NYILATKOZAT
DECLARATIA DE CONFORMITATE UE
ДЕКЛАРАЦИЯ СОТВЕТСТВИЯ ЕС

符合聲明

TUYÊN BỐ VỆ SỰ PHÙ HỢP CỦA EU

EU符合聲明

بيان التوافق مع الاتحاد الأوروبي

AB UYGUNLUK BEYANI

<p>Le fabricant / The manufacturer / Der Hersteller / 日 fabricante / Il produttore / O fabricante / De fabrikant / Tillverkare / Valmistaja / Producent / Výrobce / Proizvajalec / Výrobca / Gyártó / Fabricant / Производител / 製造商 / Nhà sản xuất / メーカー / الجعية المصنعة / Üretici :</p>	<p>SAMES KREMLIN SAS 13, chemin de Malacher 38 240 - MEYLAN - FRANCE Tél. : 33 (0)4 76 41 60 60</p>
---	---

Déclare que le matériel désigné ci-après / Herew ith declares that the equipment / erklårt hiermit, dass die / Declara que el material designado a continuació / Dichiaara che il materiale sottoindicato / Declara que o material a seguir designado / verklaart dat de hieronder aangeduide apparatuur / Kungör att den utrustning som anges här nedan / ilmoittaa, että alla mainitut laitteistot / Ośw iadzca, że w ymienione poniżej urzãdzenia / Prohlašuje, že nìže uvedené vybavení / Izjavlja, da je opisana oprema spodaj / Vyhlasuje, že zariadenie uvedené nižšie / Kijelenti, hogy a megjelölt anyag a továbbiakban / Declară că echipamentul precizat mai jos / заявляет, что указанное ниже оборудование / 特此聲明 / Dưới đây tuyên bố rằng thiết bị / 以下指定されている機器を宣言します。 / تعلن بموجب هذا المستند ان / Aşağıda belirtilen ekipmanın :

PISTOLETS MANUELS DE PULVERISATION PNEUMATIQUES / AIRSPRAY MANUAL SPRAYING GUNS
/ LUFTZERSTÄUBENDE HAND-SPRITPISTOLEN / PISTOLAS MANUALES DE PULVERIZACIÓN AEROGRÁFICA

FSTART G
FSTART P
FSTART S

Est conforme à la législation d'harmonisation de l'Union applicable suivante / Is in conformity with the relevant Union harmonisation legislation / Erfüllt die einschlägigen Harmonisierungsrechtsvorschriften der Union / es conforme con la legislación de armonización pertinente de la Unión / è conforme alla pertinente normativa di armonizzazione dell'Unione / Cumpre a seguinte legislação de harmonização da UE aplicável / in overeenstemming met de desbetreffende harmonisatiewetgeving van de Unie / med den relevanta harmoniserade unionslagstiftningen / on asiaa koskevan unionin yhdenmukaistamislainsaädännön vaatimusten mukainen / jest zgodny z odnosnymi w ymaganiami unijnego prawodawstwa harmonizacyjnego / Shoduje se s následující příslušnou evropskou harmonizační legislativou / V skladu s harmonizirano zakonodajo Unije / Je v súlade s uplatiteľnými harmonizačnými právnymi predpismi EÚ / Megfelel a következõ alkalmazandó uniós harmonizációs szabályozásnak / Este conform cu legislația aplicabilă de armonizare de mai jos / Соответствует следующим применимым законодательным актам ЕС по гармонизации / 符合相关的欧盟法规 / Phù hợp với luật hòa hợp liên quan của Liên minh / 以下のEU整合化法に準拠しています / متوافقة مع / تشريع المواصفة الصادر عن الاتحاد الأوروبي / Aşağıdaki geçerli Birlik uyum mevzuatına uygundur :

Directive ATEX / ATEX Directive / ATEX Richtlinie / Directiva ATEX / Direttiva ATEX / Diretiva ATEX / ATEX-Richtlijn / ATEX-direktivet / ATEX-direktivi / Dyrektyw a ATEX / Směrnice ATEX / Direktiva ATEX / Smernica ATEX / ATEX-irányelv / Директив a ATEX / ATEX指令 / ATEX Chi thj / ATEX指令 / ATEX توجيه / ATEX Direktifi	
 II 2G Ex h IIB T6 Gb X	
NF EN ISO 80079-36 Juin 2016 NF EN ISO 80079-37 Juin 2016 NF EN 1127-1 Août 2019	2014/34/UE
Ex h=> Protection par sécurité de construction (c) / Protection by constructional safety (c) / Schutz durch konstruktive Sicherheit (c) / Protecção por seguridad constructiva (c) / Protezione per sicurezza costruttiva (c) / Protecção por segurança construtiva (c) / Bescherming door constructieveiligheid (c) / Säker konstruktion (c) / Suojaus rakenteellisella turvallisudella (c) / Zabezpečenie za pomocou bezpečenstva a konstrukcyjnego (c) / Ochrana bezpečnou konstrukci (c) / Zaščita s konstrukcijsko varnostjo (c) / Ochrana bezpečnou konštrukciou (c) / Szerkezetbiztonsági védelem (c) / Protecție prin securitate constructivă (c) / Защита с помощью безопасности строительства (c) / 通过建筑安全保护 (c) / Bảo vệ an toàn xây dựng (c) / 工事の安全性による保護 (c) / حماية سلامة البناء (ج) / İnşaat güvenliği koruması (c)	
INERIS 0080 - 60550 Verneuil-en-Halatte - France / no INERIS-CERN 036593 / 21	

La présente déclaration de conformité est établie sous la seule responsabilité du fabricant / This declaration of conformity is issued under the sole responsibility of the manufacturer / Die alleinige Verantwortung für die Ausstellung dieser Konformitätserklärung trägt der Hersteller / La presente declaración de conformidad se expide bajo la exclusiva responsabilidad del fabricante / La presente dichiarazione di conformità è rilasciata sotto la responsabilità esclusiva del fabbricante / A presente declaração de conformidade é emitida sob a exclusiva responsabilidade do fabricante / Deze conformiteitsverklaring wordt verstrekt onder volledige verantwoording oordelbaarheid van de fabrikant / Denna försäkran om överensstämmelse utfärdas på tillverkarens eget ansvar / Tämä vaatimustenmukaisuusvakuutus on annettu valmistajan yksinomaisella vastuulla / Niniejsza deklaracja zgodności wydana zostaje na wyłączną odpowiedzialność producenta / Toto prohlášení o škodě se vydává na výhradní odpovědnost výrobce / Za izdajno te izjave o skladnosti je odgovoren izključno proizvajalec / Toto vyhlásenie o zhode sa vydáva / na vlastnú zodpovednosť výrobcu / Ezt a megfelelőségi nyilatkozatot a gyártó kizárólagos felelőssége mellett adják ti / Prezenta declarație de conformitate este emisă pe răspunderea exclusivă a producătorului / Данная декларация соответствия выдана под исключительную ответственность производителя / 本符合性声明由制造商全权负责发布 / Tuyên bố về sự phù hợp này do nhà sản xuất chịu trách nhiệm duy nhất / この適合宣言は、製造者の唯一の責任において発行されたものです。 / الجھة ال ؤمصة ؤنعة هي الجھة الوحيدة المسؤولة عن إصدار بيان التوافق هنا. / Bu uygunkluk beyanı, tamamen üreticinin sorumluluğunda yayımlanmıştır.

Hervé WALTER



Directeur Recherche & Développement / Research & Development Director / Direktor für Forschung & Entwicklung / Director de Investigación y Desarrollo / Direttore Ricerca e sviluppo / Diretor de Pesquisa e desenvolvimento / Manager Onderzoek en Ontwikkeling / Direktör för Forskning och Utveckling / Johtaja tutkimus ja kehitys / Dyrektor ds. Badań i rozwoju / Ředitel výzkumu a vývoje / Direktor za raziskave in razvoj / Řaditel' pre výskum a vývoj / Kutatási és Fejlesztési Igazgató / Director de cercetare și Dezvoltare / Директор по исследованиям и развитию / 創新研發發展總監 / Giám đốc Nghiên cứu & Phát triển / リサーチ&ディベロップメント・ディレクター / مدير الإبداع والتطوير / Araştırma ve Geliştirme Direktörü

Fait à Meylan, le / Established in Meylan, on / Geschehen zu Meylan, am / En Meylan, a / Redatto a Meylan, / Vastgesteld te Meylan, / Utformat i Meylan, den / Meylan, Ranska, / Sporządzono w Meylan, dnia / Meylan, dnia / V Meylanu, / V Meylanu dne / Kelt Meylanban, / Intocmită la Meylan, pe data de / Выполнено в Мейлане, на / 発行日Meylan, 時間 / Được lập tại Meylan, vào / Meylanで発行された。オン / بتأريخ في ميلان، / Mейlan'da yapıldı. 01/03/2021 - 03/01/2021



DECLARATION UK DE CONFORMITE
UK DECLARATION OF CONFORMITY
UK-KONFORMITÄTSEKLRÄRUNG
DECLARACIÓN UK DE CONFORMIDAD
DICHIARAZIONE DI CONFORMITÀ UK
DECLARAÇÃO UK DE CONFORMIDADE
UK-KONFORMITEITSVERKLARING
UK-FÖRSÄKRAN OM ÖVERENSSTÄMMELSE
UK-VAATIMUKSEN MUKAISUUSVAKUUTUS
DECLARACJA ZGODNOŚCI UK
UK PROHLÁŠENÍ O SHODĚ
IZJAVA UK O SKLADNOSTI
UK-VYHLÁŠENIE O ZHODE
UK-MEGFELELŐSÉGI NYILATKOZAT
DECLARATIA DE CONFORMITATE UK
ДЕКЛАРАЦИЯ СООТВЕТСТВИЯ СКА
英國符合性聲明
TUYÊN BỐ VỆ SỰ PHÙ HỢP CỦA UK
英國符合性宣言
إعلان المطابقة من المملكة المتحدة
INGLTERE UYGUNLUK BEYANI

<p>Le fabricant / The manufacturer / Der Hersteller / 日 fabricant / Il produttore / O fabricante / De fabrikant / Tilverkare / Valmistaja / Producent / Výrobce / Proizvajalec / Výrobca / Gyártó / Fabricant / Производител / 製造商 / Nhà sản xuất / 生産力 / الجوة المصنفة / Üretici :</p>	<p>SAMES KREMLIN SAS 13, chemin de Malacher 38 240 - MEYLAN - FRANCE Tél. : 33 (0)4 76 41 60 60</p>
---	---

Déclare que le matériel désigné ci-après / Herew ith declares that the equipment / erklårt hiermit, dass die / Declara que el material designado a continuació / Dichiaara che il materiale sottoindicato / Declara que o material a seguir designado / verklaart dat de hieronder aangeduide apparatuur / Kungör att den utrustning som anges här nedan / ilmoittaa, että alla mainitut laitteistot / Ošw iadzca, że w ymienione poniżej urządzenia / Prohlašuje, že e niže uvedené vybavení / Izjavlja, da je opisana oprema spodaj / Vyhlasuje, že zariadenie uvedené nižšie / Kijelenti, hogy a megjelölt anyag a továbbiakban / Declară că echipamentul precizat mai jos / заявляет, что указанное ниже оборудование / 特此声明 / Dưới đây tuyên bố rằng thiết bị / 以下で指定されている機器を宣言します。 / تعلن بموجب هذا الممسند أن / Aşağıda belirtilen ekipmanın:

PISTOLETS MANUELS DE PULVERISATION PNEUMATIQUES / AIRSPRAY MANUAL SPRAYING GUNS / LUFTZERSTÄUBENDE HAND-SPRITPISTOLEN / PISTOLAS MANUALES DE PULVERIZACIÓN AEROGRAFICA

FSTART G
FSTART P
FSTART S

Est conforme à la législation des normes désignées du Royaume-Uni suivante / Is in conformity with the UK statutory requirements / Entspricht den folgenden britischen Rechtsvorschriften für designierte Standards / Cuple con la siguiente legislación de normas designadas del Reino Unido / É conforme alla seguente legislazione sugli standard designati del Regno Unito / Está em conformidade com a seguinte legislação de Normas Designadas do Reino Unido / Voldoet aan de volgende UK Designated Standards v etgeving / Överensstämmer med följande lagstiftning om britiska standarder (UK Designated Standards) / Noudattaa seuraavia Yhdistyneen kuningaskunnan nimitettyjä standardreja koskevaa lainsäädäntöä / Zgodność z następującymi przepisami UK Designated Standards / Splňuje následující britské právní předpisy o určených normách / V skladu z naslednjo zakonodajo o imenovanih standardih v Združenem kraljestvu / Je v sllade s nasledjućimi právnými predpismi Spojeného královstva o určených normách / Megfelel a következó brit szabványokra vonatkozó jogszabályoknak / Este în conformitate cu următoarea legislație britanică privind standardele desemnate / Соответствует следующим требованиям законодательства Великобритании о назначенных стандартах / 符合以下英國指定標準的法规 / Tuân thủ luật tiêu chuẩn được chỉ định của Vương quốc Anh sau đây / 以下の英國指定標準法に準拠 / يتوافق مع تشريعات المعايير المعينة / Aşağıdaki Birleşik Krallık tarafından belirlenmiş standartlar mevzuatına uygundur :

SI 2016 No. 1107 'Equipment and Protective Systems Intended for use in Potentially Explosive Atmospheres Regulations 2016'



II 2G Ex h IIB T6 Gb X

Designated standards

NF EN ISO 80079-36 Juin 2016

NF EN ISO 80079-37 Juin 2016

NF EN 1127-1 Août 2019

Ex h=> Protection par sécurité de construction (c) / Protection by constructional safety (c) / Schutz durch konstruktive Sicherheit (c) / Protección por seguridad constructiva (c) / Protezione per sicurezza costruttiva (c) / Protecção por segurança construtiva (c) / Bescherming door constructieveiligheid (c) / Säker konstruktion (c) / Suojaus rakenteellisella turvallisudella (c) / Zabezpieczenie za pomocą zabezpieczeń konstrukcyjnego (c) / Ochrana bezpečnou konstrukci (c) / Zaščita s konstrukcijsko varnostjo (c) / Ochrana bezpečnou konštrukciou (c) / Szerkezetbiztonsági védelem (c) / Protecție prin securitate constructivă (c) / Защита с помощью безопасности строительства (c) / 通过建筑安全保护 (c) / Bảo vệ an toàn xây dựng (c) / 工事の安全性による保護 (c) / حماية سلامة البناء (ج) / Inşaat güvenliği koruması (c)

Approved Bodies INERIS 0080 - 60550 Verneuil-en-Halatte - France / no INERIS-CERN 036593 / 21
CLM 25031 - Ellesmere Port - United Kingdom / CML n°

SI 2016 No. 1107

'Equipment and Protective Systems Intended for use in Potentially Explosive Atmospheres Regulations 2016'

La présente déclaration de conformité est établie sous la seule responsabilité du fabricant / This declaration of conformity is issued under the sole responsibility of the manufacturer / Die alleinige Verantwortung für die Ausstellung dieser Konformitätserklärung trägt der Hersteller / La presente declaración de conformidad se expide bajo la exclusiva responsabilidad del fabricante / La presente dichiarazione di conformità è rilasciata sotto la responsabilità esclusiva del fabbricante / A presente declaração de conformidade é emitida sob a exclusiva responsabilidade do fabricante / Deze conformiteitsverklaring wordt verstrekt onder volledige verantwoording van de fabrikant / Denna försäkran om överensstämmelse utfärdas på tillverkarens eget ansvar / Tämä vaatimustenmukaisuusvakuutus on annettu valmistajan yksinomaisella vastuulla / Niniejsza deklaracja zgodności wydana zostaje na wyłączną odpowiedzialność producenta / Toto prohlášení o shodě se vydává na výhradní odpovědnost výrobce / Za izdajo te izjave o skladnosti je odgovoren izključno proizvajalec / Toto vyhlásenie o zhode sa vydáva / na vlastnú zodpovednosť výrobcu / Ezt a megfelelőségi nyilatkozatot a gyártó kizárólagos felelőssége mellett adja ki / Prezenta declarație de conformitate este emisă pe răspunderea exclusivă a producătorului / Данная декларация соответствия выдана под исключительную ответственность производителя / 本符合性声明由制造商全权负责发布 / Tuyên bố về sự phù hợp này do nhà sản xuất chịu trách nhiệm duy nhất / この適合宣言は、製造者の唯一の責任において発行されたものです。 / الجعة الأتمصدة هي الجعة الوحيدة المسؤولة عن إصدار بيان التوافق هذا. / Bu uygunluk beyanı, tamamen üreticinin sorumluluğunda yayımlanmıştır.

Hervé WALTER

Directeur Recherche & Développement / Research & Development Director / Direktor für Forschung & Entwicklung / Director de Investigación y Desarrollo / Direttore Ricerca e sviluppo / Diretor de Pesquisa e desenvolvimento / Manager Onderzoek en Ontwikkeling / Direktör för Forskning och Utveckling / Johtaja tutkimus ja kehitys / Dyrektor ds. Badań i rozwoju / Ředitel výzkumu a vývoje / Direktor za raziskave in razvoj / Riaditeľ pre výskum a vývoj / Kutatási és Fejlesztési Igazgató / Director de cercetare și Dezvoltare / Директор по исследованиям и развитию / 创新与发展总监 / Giám đốc Nghiên cứu & Phát triển / リサーチ&ディベロップメント・ディレクター / مدير الإبداع والتطوير / Araştırma ve Geliştirme Direktörü

Fait à Meylan, le / Established in Meylan, on / Geschehen zu Meylan, am / En Meylan, a / Redatto a Meylan, / Vastgesteld te Meylan, / Utformat i Meylan, den / Meylan, Ranska, / Sporządzono w Meylan, dnia / Meylan, dnia / V Meylanu, / V Meylan dňa / Kelt Meylanban, / Intocimă la Meylan, pe data de / Выполнено в Мейлане, на / 发布于 Meylan, 时间 / Được lập tại Meylan, vào / Meylanで行われた、オン / تأسست في ميلان، بتاريخ / Meylan'da yapıldı. 01/03/2021 - 03/01/2021