



SHOVEL PUMP

910 cm³

Pump REX SH0910

User Manual 582179110

2024-03-19

Index D

Translation of the original instructions

SAMES KREMLIN SAS



13 Chemin de Malacher
38240 Meylan



www.sames-kremlin.com



33 (0)4 76 41 60 60

Any communication or reproduction of this document, in any form whatsoever, and any exploitation or communication of its contents are prohibited, except with the express written consent of

SAMES KREMLIN.

The descriptions and features contained in this document are subject to change without notice.

© **SAMES KREMLIN** 2021

Contents

<i>Evolution table of the document</i>	5
<i>Additional documentations</i>	5
<i>Guarantee</i>	6
1 Declaration of Conformity	7
2 Safety instructions	8
2.1 Personal safety.....	8
<i>Overview</i>	8
<i>Meaning of the pictograms</i>	9
<i>Security devices</i>	10
<i>Danger of Pressure</i>	10
<i>Injection hazards</i>	11
<i>Fire hazards, explosion, electric arc, static electricity</i>	11
<i>Toxic products hazards</i>	12
2.2 Integrity of the material	13
<i>Material recommendations</i>	13
<i>Pump</i>	13
<i>Tubing</i>	13
<i>Products implemented</i>	14
3 Environment	15
4 Available Configurations	17
4.1 Rexson part numbers of high viscosity pumps.....	17
4.2 Table 1 Fluid section-Air motor selection	18
4.3 Table 2 Fluid section – Pump foot & Material selection.....	18
4.4 Table 3 Seals Pack selection	19
5 Identification	20
5.1 Description of the marking of the plate	20
5.2 Correspondence table new part numbers / Significant designations.....	22
5.3 Correspondence table existant part numbers / Significant designations	23
6 Technical characteristics and performances	24
6.1 General characteristics	24
6.2 Principle of operation	26
<i>Expected use</i>	26
<i>Functional description</i>	26
7 Installation	28
7.1 Handling	28
7.2 Connections subsets	28
7.2.1 <i>Fluid supply connection</i>	28
7.2.2 <i>Air supply connection</i>	29
7.3 Storage	29
8 Commissioning	30

Pump.....	30
Motor	30
9 Use of the product.....	31
9.1 User settings.....	31
<i>Wet Cup</i>	31
<i>Tightening of the Wet Cup</i>	31
<i>Tightening procedure</i>	31
9.2 Safety in production	32
9.3 Start up	32
9.4 Shutdown procedure.....	33
<i>Pump</i>	33
9.5 Diagnostic help / Troubleshooting guide	34
<i>Possible symptoms of faults / Causes of faults / Remedies to apply</i>	34
10 Maintenance	36
10.1 Preventive Maintenance Plan	37
<i>Fluid section</i>	37
10.2 General preconisation maintenance	38
11 Disassembly / Reassembly Operation.....	39
<i>Greases and threads lockers designations</i>	39
<i>Disassembly of the pump</i>	41
<i>Cup seals</i>	42
<i>Lower valve</i>	42
<i>Upper valve</i>	43
<i>Reassembly of the fluid section</i>	44
12 Spare parts	45
.....	46
<i>Lower adapter flange</i>	47
<i>Servicing kit composition # 106 364</i>	48
<i>Seal kits recommended</i>	48
<i>Accessory</i>	48
<i>Seals packs composition: 01 to 03</i>	49
<i>Seals packs composition: 04 to 06</i>	50
<i>Seals packs composition: 07 and 08</i>	50

Evolution table of the document

Recording revisions				
Editor	Object	Revision	Date	Modified by
SEGUIN	Shovel fluid section 910 cm ³ REXSON SH910	A	05/01/2021	
SEGUIN	Shovel fluid section 910 cm ³ REXSON SH910	B	02/09/2021	
SEGUIN	Shovel fluid section 910 cm ³ REXSON SH910	C	09/29/2021	
SEGUIN	Shovel fluid section 910 cm ³ REXSON SH910	D	03/19/2024	

Dear customer, you have just purchased your new equipment and we thank you for it.

We have taken the utmost care, from design to manufacture, so that this equipment gives you complete satisfaction.

For a good use and an optimal availability, we invite you to read this manual carefully before using your equipment.

Additional documentations

	Documentation Reference
Air Motor 7200	582144110
Air Motor 9200	582145110

IMPORTANT: before assembly and start-up, please read and clearly understand all the documents relating to this equipment (professional use only).

Guarantee

We reserve the right to make any changes or improvements even after receipt of an order without being able to attribute a non-compliance to the descriptions contained in the instruction manuals and selection guides.

Our equipment is checked and tested in our workshops before shipment.

To be valid, any complaint concerning a material will have to be formulated to us in writing within 10 days of the delivery.

SAMES KREMLIN equipment, equipped with its original identification plates, has a one-year warranty or 1800H of operation (in the first term reaches) from the date of ex-factory against any defect of material or defect of it is up to us to see and appreciate.

The warranty excludes wear parts, deterioration or wear resulting from abnormal or unscheduled use by **SAMES KREMLIN**, failure to observe instructions for proper operation or lack of maintenance.

The warranty is limited to the repair or exchange of parts returned to our factory and recognized as defective by us and does not cover the listed wear parts.

Any costs resulting from the operation cannot be charged to us. The costs of return to our workshops are the responsibility of the customer.

An intervention can be carried out on site at the customer's request.

In this case, the transportation and accommodation costs of the technician (s) will remain the responsibility of the applicant.

Any changes made to our equipment without our consent will void the warranty.

Our guarantee is limited to that of the suppliers of materials which enter in the composition of our sets.

1 Declaration of Conformity



Refer to the existing declaration delivered with the product.

2 Safety instructions

2.1 Personal safety

Overview



Read all operating instructions and device labels carefully before putting the equipment into service.

Personnel using this equipment must have been trained in its use.

The workshop manager must ensure that the operators have fully understood all the instructions and safety rules of this equipment and other elements and accessories of the installation.

Misuse or operation can cause serious injury. This material is for professional use only. It must be used only for the purpose for which it was intended.

Do not modify or transform the material. Parts and accessories must only be supplied or approved by **SAMES KREMLIN**.

The equipment must be checked periodically. Defective or worn parts must be replaced.

Never exceed the maximum working pressures of the equipment components.

Always respect the laws in force regarding security, fire, electricity of the destination country of the equipment.

Only use products or solvents that are compatible with the parts in contact with the product (see product manufacturer's technical data sheet).

Meaning of the pictograms

 <p>Danger: pinching, crushing</p>	 <p>Danger: moving parts</p>	 <p>Danger: high pressure</p>	 <p>Risks of product emanation</p>
 <p>Danger: hot parts or surfaces</p>	 <p>Danger: flammability risks</p>	 <p>Danger: electricity</p>	 <p>Risk of explosion</p>
 <p>Danger (user)</p>	 <p>Warning Danger</p>	 <p>Gloves required</p>	 <p>Grounding</p>
 <p>Protective helmet</p>	 <p>Hearing protection</p>	 <p>Mandatory respiratory protection</p>	 <p>Safety shoes</p>
 <p>Protective clothing</p>	 <p>Protective visor</p>	 <p>Safety glasses is mandatory</p>	 <p>Refer to the manual/instruction leaflet</p>

Security devices



Attention

- ✓ Guards (motor cover, coupling guard, housings, ...) are set up for safe use of the equipment.
- ✓ The manufacturer cannot be held responsible for any bodily injury as well as failures and / or damage to the equipment resulting from the destruction, the occultation or the total or partial removal of the protectors.
- ✓ Never exceed the maximum working pressures of the equipment components.

Danger of Pressure



Safety requires that a pressure relieve shutoff valve be mounted on the pump motor supply circuit to allow trapped air to escape when the air supply is shut off.

Without this precaution, the residual air from the engine may cause the motor pump to operate and cause a serious accident.

Similarly, a **material bleed valve** must be installed on the material circuit so that material pressure can be relieved (after shutting off air motor and decompressing it) before any intervention on the equipment. These valves should remain closed for air and open for the material during the procedure.

Injection hazards



"HIGH PRESSURE" technology requires the utmost care.

Operation can cause dangerous leaks. There is a risk of product injection into exposed parts of the body, which can lead to serious injury and the risk of amputation:

- ✓ An injection of product into the skin or other parts of the body (eyes, fingers ...) must be treated urgently by appropriate medical care.
- ✓ Do not look at the gun nozzle when it is under pressure.
- ✓ Never point the gun nozzle at another person.
- ✓ Never attempt to stop the jet with the body (hands, fingers ...) or with rags or similar.

**Fire hazards, explosion,
electric arc, static
electricity**



Improper grounding, insufficient ventilation, open flames or sparks can cause an explosion or fire which could result in serious injury.

To avoid these risks, especially when using pumps, it is imperative:

- ✓ Before operating the Pump supply system make sure that all Pump equipment and material containers are grounded,
- ✓ To ensure good ventilation,
- ✓ Keep the work area clean and free of rags, papers, solvents,
- ✓ Do not operate electrical switches in the presence of vapors or during removal,
- ✓ Immediately stop the application in the presence of arcs,
- ✓ Store all liquids outside the work areas.
- ✓ Use products whose flash point is as high as possible to avoid any risk of formation of flammable gases and vapors (consult the product safety data sheets).
- ✓ To equip the drums with a lid to reduce the diffusion of gases and vapors in the cabin.
- ✓ It is forbidden to pump explosive materials.

Toxic products hazards



Toxic products or vapors can cause serious injury through contact with the body, in the eyes, under the skin, but also by ingestion or inhalation. It is imperative:

- ✓ To know the type of product used and the dangers it represents,
- ✓ Store the products to be used in appropriate areas,
- ✓ Contain the product used in the application in a container designed for that purpose,
- ✓ Treat product waste with the legislation of the country where the equipment is used,
- ✓ To wear protective clothing designed for that purpose,
- ✓ Wearing goggles, hearing protectors, gloves, shoes, coveralls and masks for the respiratory tract.



Attention

The use of halogenated hydrocarbon solvents and products containing these solvents in the presence of aluminum or zinc is prohibited.

Failure to follow these instructions exposes the user to the risk of explosion resulting in serious injury or death.

2.2 Integrity of the material

Material recommendations



Protectors are put in place for safe use of the equipment.

The manufacturer cannot be held responsible in case of:

- ✓ Bodily injury.
- ✓ As well as breakdowns and / or damage to the equipment resulting from the destruction, the misuse or the total or partial withdrawal of the protectors.

Pump

It is imperative to be aware of the compatibility of the motors and pumps before coupling them together as well as the special safety instructions. These instructions can be found in the instruction manuals of the pumps.

The air motor is intended to be coupled to a pump. Never modify the coupling system. Keep hands away from moving parts. The moving parts must be kept clean. Before commissioning or using the motor pump, read carefully the DECOMPRESSURIZATION PROCEDURE. Check the proper operation of the pressure relief and bleed air valves.

Tubing

Recommendations

- ✓ Keep hoses away from traffic areas, moving parts and hot areas.
- ✓ Never subject hoses being produced to temperatures above 80°C or below 0°C.
- ✓ Do not use hoses to pull or move equipment.
- ✓ Tighten all connections and hoses and couplings before operating equipment.
- ✓ Check hoses regularly and replace if damaged.
- ✓ Never exceed the maximum working pressure (MWP) stated on the hose.
- ✓ When fitting the hoses and the gun, PPE must be worn.
- ✓ Tighten to full stop (hoses + gun).

Products implemented

Given the diversity of the products implemented by the users and the impossibility of listing all the characteristics of the chemical substances, their interactions and their evolution over time

SAMES KREMLIN can not be held responsible:

- ✓ The poor compatibility of materials in contact.
- ✓ Inherent risks to staff and the environment.
- ✓ Wear and tear, maladjustment, malfunction of equipment or machines and the quality of the finished product.

The user will have to identify and prevent the potential dangers inherent to the implemented products such as:



- ✓ Toxic vapors.
- ✓ Fire.
- ✓ Explosions.

It will determine the risks of immediate reactions or due to repeated exposures to the staff.

SAMES KREMLIN declines any responsibility, in case of:

- ✓ Bodily or psychic injuries.
 - ✓ Direct or indirect material damage due to the use of chemical substances.
-

3 Environment

The equipment must be installed on a horizontal, stable and flat ground (eg concrete slab).

Non-moving equipment must be fixed to the ground by suitable fasteners (spit, screws, bolts, ...) to ensure their stability during use.



To avoid risks due to static electricity, the equipment and its components must be grounded.

- ✓ **In combination with a pneumatic motor, the hydraulics will be earthed with the earth cable of this motor.** This earth cable must be connected to a safe earth.
 - ✓ Have the earth continuity checked by a qualified electrician. If earth continuity is not assured, check terminal, wire and grounding point. Never operate the equipment without solving this problem.
-



- ✓ **Do not store** more flammable products than necessary inside the work area.
 - ✓ These products must be stored in **approved containers** and grounded.
 - ✓ Use only grounded **metal buckets** for the use of rinse solvents.
 - ✓ **Cartons and papers are to be banned.** Indeed they are very bad conductors, even insulators.
-

Material marking

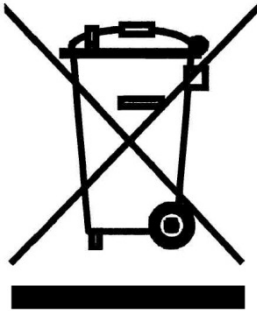

Each device is equipped with an identification plate with the name of the manufacturer, the reference of the device, important information for the use of the device (pressure, power, ...) and sometimes against the pictogram shown below.

The equipment is designed and manufactured with high quality materials and components that can be recycled and reused.

European Directive 2012/19 / EU applies to all devices marked with this logo (crossed out bin). Find out about the collection systems available for electrical and electronic devices.

Comply with the rules in your area and **do not dispose of old appliances with household waste**. Proper disposal of this old device will help prevent adverse effects on the environment and human health.

4 Available Configurations

4.1 Rexson part numbers of high viscosity pumps

Presentation of the pump REXSON SH910

A very versatile pump, the REXSON SH910 hydraulic is used for airless applications as well as for the extrusion of thick products (>50000 cP*).

Different configurations are available.

* 1 cP = 1 mPa.s

Significant designation

REX	SH	0910	-	□	-	□	-	□	-	□
------------	-----------	-------------	---	---	---	---	---	---	---	---

Ex : R E X S H 0910 - 72 - C S - F P - 06

Product family

High viscosity pump : **REX**

Technology

Shovel pump **SH**

Cycle volume

4 digits in cm³

Air motor

None : **XX**
 Motor 7200 : **72**
 Motor 9200 : **92**
[Refer table 1](#)

Seals packs

PTFE : **01**
 PTFE + FEP : **02**
 PE : **03**
 Leather : **04**
 PTFE G : **05**
 PU : **06**
 PTFEV : **07**
 PEHD : **08**
[Refer table 3](#)

Pump foot

FP : Follower plate
PC : Plain cylinder
[Refer table 2](#)

Material of construction

CS : Mixed steels
SS : Stainless steels
[Refer table 2](#)

4.2 Table 1 Fluid section-Air motor selection

Available Motors		Pressure Ratio	Maximum Air Inlet Pressure		Maximum Outlet Fluid Pressure		Documentation reference
			bar	psi	bar	psi	
XX	NONE	-	-		-		-
72	MOTOR 7200	18 : 1	6	100	110	1600	582144110
92	MOTOR 9200	30 : 1	6	100	180	2600	582145110

R E X S H 0 9 1 0 - - - -

4.3 Table 2 Fluid section – Pump foot & Material selection

Available foot pump		Available material	
		CS	SS
		Mixed steels	Stainless steels
FP	Follower plate	✓	✓
PC	Plain cylinder	✓	x

R E X S H 0 9 1 0 - - -

4.4 Table 3 Seals Pack selection

Available seals packing		Static seals "O"-rings	Upper seals packing	Piston seals packing	Lower valve seals packing
01	PTFE	FKM	PTFE	PTFE	PTFE
02	PTFE+FEP	FEP	PTFE	PTFE	PTFE
03	PE	FKM	PTFE and PE	PTFE and PE	PTFE
04	Leather	FKM	Leather and PE	Leather and PE	PTFE
05	PTFEG	FKM	PTFEG	PTFEG	PTFE
06	PU	FKM	PU and PE	PTFEG	PE and PTFEV
07	PTFEV	FKM	PU and PE	PE and PTFEV	PE and PTFEV
08	PEHD	FKM	PEHD	PEHD	PTFE



PTFE=Polytetrafluoroethylene (Teflon like properties) / PTFEG=PTFE + Graphite (impregnated)
 PE=Polyethylene (UHMWPE) / FKM=Flouroelastomer (Viton like properties)
 PU=Polyurethane / PTFEV=PTFE + Glass (impregnated)
 FEP=Encapsulated O-Ring (Teflon like properties over Viton or Silicone)
 PEHD= High-density Polyethylene

5 Identification



5.1 Description of the marking of the plate

Principles

This equipment complies with the following provisions:

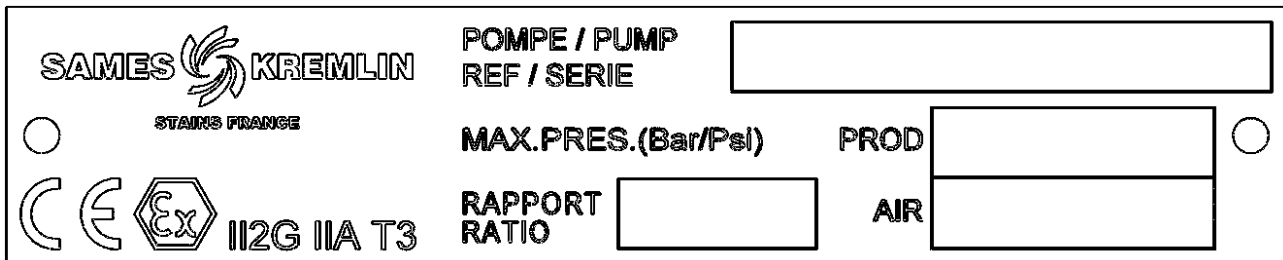
- ✓ Machinery Directive (2006/42 / EC),
- ✓ Safety of machinery - Basic terms, general implementation guidelines DIN EN ISO 12100 T1/T2
- ✓ ATEX Directive (2014/34 / EU: II 2 G - Group II, Category 2, Gas).



Description	
SAMES KREMLIN STAINS FRANCE	Manufacturer's mark
POMPE / PUMP REF / SERIE	Pump reference and serial number. The first two digits indicate the year of manufacture.
MAX. PRES. (Bar/Psi)	PROD Maximum product pressure (Bar/Psi)
	AIR Maximum air pressure (Bar/Psi)
RAPPORT / RATIO	Pump pressure ratio
CE	EC: European conformity
	<p> : Use in explosive area</p> <p>II : group II 2 : category 2</p> <p>Surface material intended for an environment in which explosive atmospheres due to gases, vapors, mists are likely to occasionally occur during normal operation.</p> <p>G : gas</p>
IIA T3	<p>IIA : Reference gas for equipment qualification</p> <p>T3 : Maximum surface temperature 200 ° C / 392°F</p>

5.2 Correspondence table new part numbers / Significant designations

New part numbers		Significant designations
62 MO 0910 M S F 000		REXSH0910-MO-MA-FO-SE
	Options	
MO	Motor	MO
55	MOT7200	72
56	MOT9200	92
M	Material	MA
1	Mixed Steels	CS
2	Stainless Steel	SS
S	Seal	SE
1	PTFE	01
2	PTFE +FEP	02
3	PTFE /PE	03
4	Leather	04
5	PTFE G	05
6	PU	06
7	PTFEV	07
8	SPECIAL UV INK	08
F	Foot	FO
2	Follower plate Ø 105 mm	FP
5	Plain cylinder Ø 110 mm	PC

Référence Documentation	
Air Motor 7200	582144110
Air Motor 9200	582145110

5.3 Correspondence table existant part numbers / Significant designations

Existant part number	Significant designation	Motor	Material	Foot	Seal
472 262 060 204	REXSH0910-72-CS-FP-04	MOT7200 18 : 1	CS Mixed Steels	FP Follower plate Ø 105 mm	04 Leather
492 262 060 205	REXSH0910-92-CS-FP -05	MOT9200 30 : 1	CS Mixed Steels	FP Follower plate Ø 105 mm	05 PTFE G
1 062 060 206	REXSH0910-XX-CS-FP -06	None	CS Mixed Steels	FP Follower plate Ø 105 mm	06 PU
492 262 060 206	REXSH0910-92-CS-FP-06	MOT9200 30 : 1	CS Mixed Steels	FP Follower plate Ø 105 mm	06 PU
997 000 377	REXSH0910-H2-CS-FP-06	H2	CS Mixed Steels	FP Follower plate Ø 105 mm	06 PU
1 062 061 001	REXSH0910-XX-SS-FP-01	None	SS Stainless steel	FP Follower plate Ø 105 mm	01 PTFE
1 062 061 005	REXSH0910-XX-SS-FP-05	None	SS Stainless steel	FP Follower plate Ø 105 mm	05 PTFE G
1 062 061 006	REXSH0910-XX-SS-FP-06	None	SS Stainless steel	FP Follower plate Ø 105 mm	06 PU
492 262 061 006	REXSH0910-92-SS-FP-06	MOT9200 30 : 1	SS Stainless steel	FP Follower plate Ø 105 mm	06 PU

6 Technical characteristics and performances

6.1 General characteristics

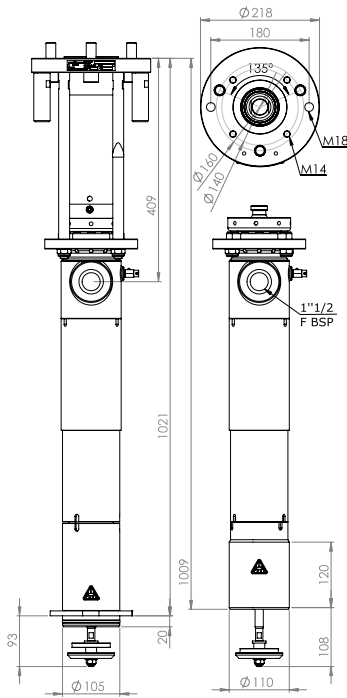

Technical characteristics	
Volume per cycle	910 cm ³ / 30,77 oz
Stroke	200 mm / 7,87 in
Fluid outlet connection	1" 1/2 F BSPP
Weight	44 kg / 97 lb
Maximum fluid temperature	80°C / 176°F
Wetted parts	Depending on materials of construction and seals kits
Packings	Depending on seals kits

Available Motors		Motor selection		
		XX	72	92
		NONE	MOTOR 7200	MOTOR 9200
Pressure Ratio		-	18 : 1	30 : 1
Maximum Air Inlet Pressure	bar	-	6	6
	psi	-	100	100
Maximum Outlet Fluid Pressure	bar	-	110	180
	psi	-	1600	2600
Minimum Outlet Fluid Pressure	bar	-	27	45
	psi	-	392	653
Complete Pump Weight	Kg	-	72	81
	Lbs	-	158.8	178.6
Air consumption 15 Cycles/min @ 4 bar	NL.min-1	-	983	1638
	scfm	-	34,7	57,8
Air inlet fitting	Female BSPP	-	3 / 4 "	3 / 4 "

scfm= Standard cubic feet of gas per minute

(General characteristics - continued)

Pump Foot		Technical characteristic
FP	Follower Plate	Ø 105 mm
PC	Plain Cylinder	Ø 110 mm

Materials of construction		CS	SS
		Mixed steels	Stainless steel
Pump body	Wet Cup	Carbon steel + Zinc treatment	Carbon steel + Zinc treatment
	Upper body	Stainless steel	Stainless steel
	Cylinder	Carbon steel + Chromium treatment	Stainless steel chromed
Piston (Upper check)	Piston rod	Stainless steel chromed	Stainless steel chromed
	Nut	Carbon steel + Zinc treatment	Stainless steel
	Valve cone	Stainless steel	Stainless steel
	Valve seat	Stainless steel	Stainless steel
Lower valve (Lower check)	Body	Carbon steel	Stainless steel
	Cone	Stainless steel	Stainless steel
	Seat	Stainless steel	Stainless steel
Foot	Rod	Stainless steel	Stainless steel
	Shovel	Carbon steel + Zinc treatment	Stainless steel
	Inlet tube	Carbon steel + Zinc treatment	Stainless steel

6.2 Principle of operation

Expected use

These pumps coupled to air or hydraulic motors are intended for transferring, or spraying different liquid or pasty products with a desired flow rate and output pressure.

Functional description

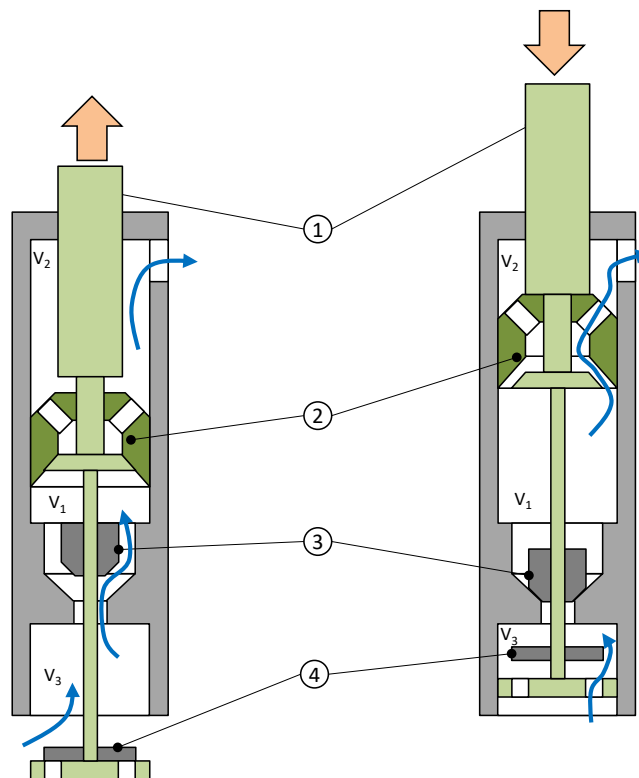

When the piston (1) rises, the upper flap (2) closes, the lower flap (3) opens and the pallet (4) closes. The piston (1) expels the product from the upper chamber (V2) to the outside and sucks the product to fill the lower chamber (V1). The pallet pushes the product into the pump foot (V3)

When the piston (1) goes down, the upper flap (2) opens, the lower flap (3) closes and the pallet (4) opens. The piston (1) compresses the fluid in the lower chamber (V1) and transfers it to the upper chamber (V2). Since the volume of the upper chamber (V2) is half that of the lower chamber (V1), a volume equivalent to the upper chamber (V2) is expelled from the pump. The pallet (4) exits the pump foot (V3) without expelling the product.

**ATTENTION!**

The friction generated by the movement of the product inside the pump and its accessories, as well as that caused by the seals, creates static electricity that can cause fire or explosion. Therefore, the fluid section system must be earthed via the motor ground cable (see the motor instruction manual for its ground connection).

7 Installation

7.1 Handling

Fluid sections of great weight and size must be handled with suitable lifting equipment.

7.2 Connections subsets



- ✓ These fluid sections are intended to be coupled to motors (pneumatic or hydraulic) with compatible stroke.
- ✓ It is imperative to comply with an air motor / hydraulic combination provided by **SAMES KREMLIN**
- ✓ Make sure that all connections of the pump and fluid section components - cables, hoses and pipes - are installed in such a way that they do not cause people to fall.
- ✓ Make sure that the order in which the cables, hoses and pipes are connected is in accordance with the connection diagram.
- ✓ Make sure that all cable connectors, hose and pipe connections are correctly fitted.
- ✓ Remember that unconnected or incorrectly connected cables, hoses and pipes can lead to malfunctions that endanger the safety of operating personnel.

7.2.1 Fluid supply connection



- ✓ If the supply pressure is higher than the max. pressure, it is necessary to install a fluid pressure regulator the closest possible of the equipment.
 - ✓ Ensure that a short product hose reduces pressure fluctuations and pressure drops.
 - ✓ Make sure that the fluid supply is properly made. The nominal size of the fitting to be used depends on the nominal size of the fluid hose.
-

7.2.2 Air supply connection

- ✓ Ensure that in bound air supply and hose are of correct size to reduce pressure fluctuations and pressure drops.
-

7.3 Storage

Pump

Place the equipment away from moisture after closing the various air inlets and various openings (plugs).

Storage before installation:

- ✓ Storage ambient temperature: 0 / +50 ° C.
- ✓ Protect the unit against dust, water runoff, moisture and shocks.

Storage after installation:

- ✓ Protect the unit against dust, water runoff, moisture and shocks.
-

8 Commissioning



The fluid sections are integrated in a system, if necessary refer to any additional instructions for further information on commissioning.

Pump

Pumps are tested for operation at the factory using a light weight oil lubricant.

Before commissioning, this lubricant must be removed by flushing with a suitable solvent.

At the end of the day, flush with a suitable solvent.

It is advisable to stop the fluid section in the "low" position in order to prevent the product from taking hold of the piston rod.

Motor

The Air motors are tested before their shipment. Nevertheless:

- ✓ Before coupling the Air motor to a fluid section pump, it is recommended to run the air motor at a low air pressure (1 bar / 14.5 psi max) for a few minutes.
 - ✓ Couple the motor with the recommended pump fluid section.
-

9 Use of the product

9.1 User settings

Wet Cup

Before commissioning, fill the wet cup halfway with lubricant "T".

The wetting cup nut must be tightened moderately. Overtightening quickly damages the gland packing. A wrench is supplied to allow proper tightening.

Tightening of the Wet Cup

- ✓ Verify cup is filled with lubricant T,
 - ✓ Run the pump, then tighten the cup after 10 minutes, again after 1 hour, then after 1 day of operation,
 - ✓ In the event of a leak, the cup must be tightened.
-

Tightening procedure

- ✓ Depressurize the Air motor (see depressurization procedure),
 - ✓ Depressure the product circuit (see depressurization procedure),
 - ✓ Tighten the cup, clean it and fill it with lubricant T,
 - ✓ Close the pump purge circuits,
 - ✓ Open the Air motor air valve.
-

9.2 Safety in production



Guards (motor cover, coupling guard, housings, ...) are set up for safe use of the equipment.

The manufacturer can not be held responsible in case of bodily injury as well as breakdowns and / or damage of the material resulting from the destruction, the occultation or the total or partial removal of the protectors.

9.3 Start up



Pumps are tested for operation at the factory using a light weight oil lubricant.

Before starting up, you must flush the pump with the appropriate solvent.

At the end of the working day, carry out a flushing with the appropriate solvent. We advice you to stop the fluid section in the "low position" to prevent material spreading on the piston rod.

9.4 Shutdown procedure

Pump



To avoid the risk of personal injury, material injections, injuries caused by moving parts or electric arcs, it is imperative that the following procedure be followed before any work is carried out when shutting down the system, assembling, cleaning or changing the nozzle.

- ✓ Lock the guns (valve, tap...) on OFF.
- ✓ Shut off the air supply through the shut off valve to remove residual air from the motor.
- ✓ Unlock the gun (valve, tap...).
- ✓ Bring the gun (valve, tap...) close to a metal bucket in order to recover the product. Hold it against the wall of the bucket to avoid interrupting the grounding continuity (if necessary, use the wire with clamp to ground the metal bucket).
- ✓ Open the gun (valve, tap) in order to drain the circuit.
- ✓ Lock the gun (valve, tap) in the OFF position.
- ✓ Open the pump drain valve and collect the fluid in a properly grounded metal pail.
- ✓ Leave the bleed valve open during the entire operation.



Check the conformity of the wiring before intervention.

9.5 Diagnostic help / Troubleshooting guide

Possible symptoms of faults / Causes of faults / Remedies to apply

Defaults	Possible causes	Remedies
Leakage at the cup seals	Insufficient tightening of the packing nut	Tighten the cup.
	Incorrect assembly of seals	Check the assembly.
	Damaged or worn seals	Replace them.
	Incorrect selection of the material of the joints	Check compatibility.
The cup seals get rapidly damaged	No lubricant in the cup (pumped product drying on the piston rod).	Clean, replace parts if necessary. When stopping for a long time, stop the pump with the piston in the low position.
	Product compatibility / seals	Check.
The pump is stopped	The fluid is polymerized, hardened, dried in the pump.	Clean the pump, change the parts if necessary.
	The cup is too tightened.	Loosen.
	Broken part(s) in the pump.	Remove, check, replace.
The motor seems to operate but the pump does not deliver product	Internal parts of the motor failing	Check the operating of the motor.
	Defective coupling.	Check coupling.
The pump operates but irregular flow	Valve clogged on the seat, incorrectly mounted or worn.	Check mounting, state of the parts, tightening of parts and seals.
	Air inlet in the suction circuit.	
At stop, pump piston continues to move on going down	Valve worn or incorrectly mounted	Check and replace parts.
	Plug or drain valve not tightened	
At stop, pump piston continues to move on going up	Head piston seals or upper valve worn or incorrectly mounted.	Check and replace parts.
	Plug or drain valve not tightened	

Defaults	Possible causes	Remedies
Pump strokes quickly downward (simple effect working)	Bad feeding of the pump.	Check use parameters of the accessories (pressure on follower plate or suction rod...). Accessories can be not adapted or clogged.
	Product is too viscous.	Bad definition of the pump.
	Lower valve worn.	Check and replace parts.
	A foreign product obstructs the lower valve.	Clean and check.
Pump strokes quickly upward	Valve worn or damaged.	Check and replace parts.
	A foreign product obstructs the upper valve.	Clean and check.
Pump cycles up and down at different speeds	Valve, head piston seals or cylinder worn.	Replace parts.
	Seals incorrectly mounted or damaged	Check the mounting; change if necessary.
The pump does not deliver enough pressure	Insufficient air pressure to the motor (valve insufficiently open, air leak,...)	Check; adjust.
	Insufficient air inlet on the motor or outlet clogged.(hose not adapted)	Check filter, mounting, hose not adapted.
	Cup or head piston seals too tightened.	Check mounting or loosen cup nut.
Abnormal operating after racing or to elevated temperature.	Head piston or cup seals too tightened, damaged.	Check mounting; reduce pumping rhythm. Replace parts if necessary.
	Product drum empty.	Fill the drum; check the suction circuit and possible air leakage.
Fluid leakage from the pump body	Cylinder tightened	Check parts and change them if necessary
	No seals or seals damaged	

10 Maintenance



Attention

Before any pump maintenance or service work performed, it is imperative to follow the depressurization procedure and the safety instructions.

Only qualified personnel should be allowed to carry out the following interventions. Observe the safety instructions given in this and all other documentation.

These procedures cover only the most common problems. If the information given here does not solve the problem you are experiencing, please contact your local **SAMES KREMLIN** representative for assistance.

During prolonged shutdown, stop the pump when the piston is in the low position.



Guards (motor cover, coupling guard, housings, ...) are set up for safe use of the equipment.

The manufacturer can not be held responsible in case of bodily injury as well as breakdowns and / or damage of the material resulting from the destruction, the occultation or the total or partial removal of the protectors.

10.1 Preventive Maintenance Plan



ATTENTION

Before any pump maintenance or service work performed, it is imperative to follow the depressurization procedure and the safety instructions.

Routine maintenance after a certain number of operating hours is recommended.

This is defined by the service department of the user and depends on the product, the working cycle and the usual pressure.

Take note of the disassembly/reassembly of the pump and the spare parts.

Fluid section

Daily

- ✓ Detect leaks at connections.
- ✓ Check the condition of the hoses.
- ✓ Observe the piston rod of the pump. Do not let the product dry onto the piston rod.
- ✓ Check the lubricant level inside the cup (keep it at half level). Fill it if necessary. It is normal for this lubricant to stain.
- ✓ Tighten the packing cup moderately with the supplied wrench, if necessary.
- ✓ Check the tightness of the components.
- ✓ If the pump is equipped with a pusher plate:
 - check the condition of the plate seal,
 - clean the top and bottom of the follower plate.
- ✓ Operate all valves in the system.
- ✓ Clean the site and the environment.

Twice a month

- ✓ If the lubricant is strongly colored in the cup, renew it.
- ✓ Check that the cup remains clean and clean it regularly with solvent after draining the lubricant.

10.2 General preconsation maintenance



ATTENTION

Before any pump maintenance or service work performed, it is imperative to follow the depressurization procedure and the safety instructions.

Before each reassembly

- ✓ Clean the parts with the appropriate cleaning solvent.
 - ✓ Fit new seals if necessary, after greasing them.
 - ✓ Grease the piston and the inside of the cylinder to avoid damaging the seals.
 - ✓ Fit new parts if necessary.
-

11 Disassembly / Reassembly Operation



ATTENTION

Before any pump maintenance or service work performed, it is imperative to follow the depressurization procedure and the safety instructions.



ATTENTION

The equipment is subject to the ATEX directive and must not be modified under any circumstances.

Failure to comply with this recommendation does not engage our responsibility.

Before each reassembly

- Clean the parts with the appropriate cleaning solvent.
- Fit new seals if necessary, after greasing them.
- Grease the piston and the inside of the cylinder to avoid damaging the seals.
- Fit new parts if necessary.

Greases and threads lockers designations

Index	Instruction	Description	Part number
A 1	PTFE grease	'TECHNI LUB' grease (10 ml / 0.0026 US gal)	560.440.101
A 2	Anti-seize grease	Grease box (450 g / 0.99 lb)	560.420.005
C 1	Medium strength Aneorobic Pipe sealant	Loctite 5772 (50 ml / 0.013 US gal)	554.180.015
C 3	Medium strength Aneorobic Adhesive	Loctite 270 (50 ml / 0.013 US gal)	554.180.004
S 1	Screwing torque : 20 Nm / 14.75 ft/lbs		

Fluid Section Follower Plate & Plain cylinder

REXSH0910-□-□-FP-□
REXSH0910-□-□-PC-□

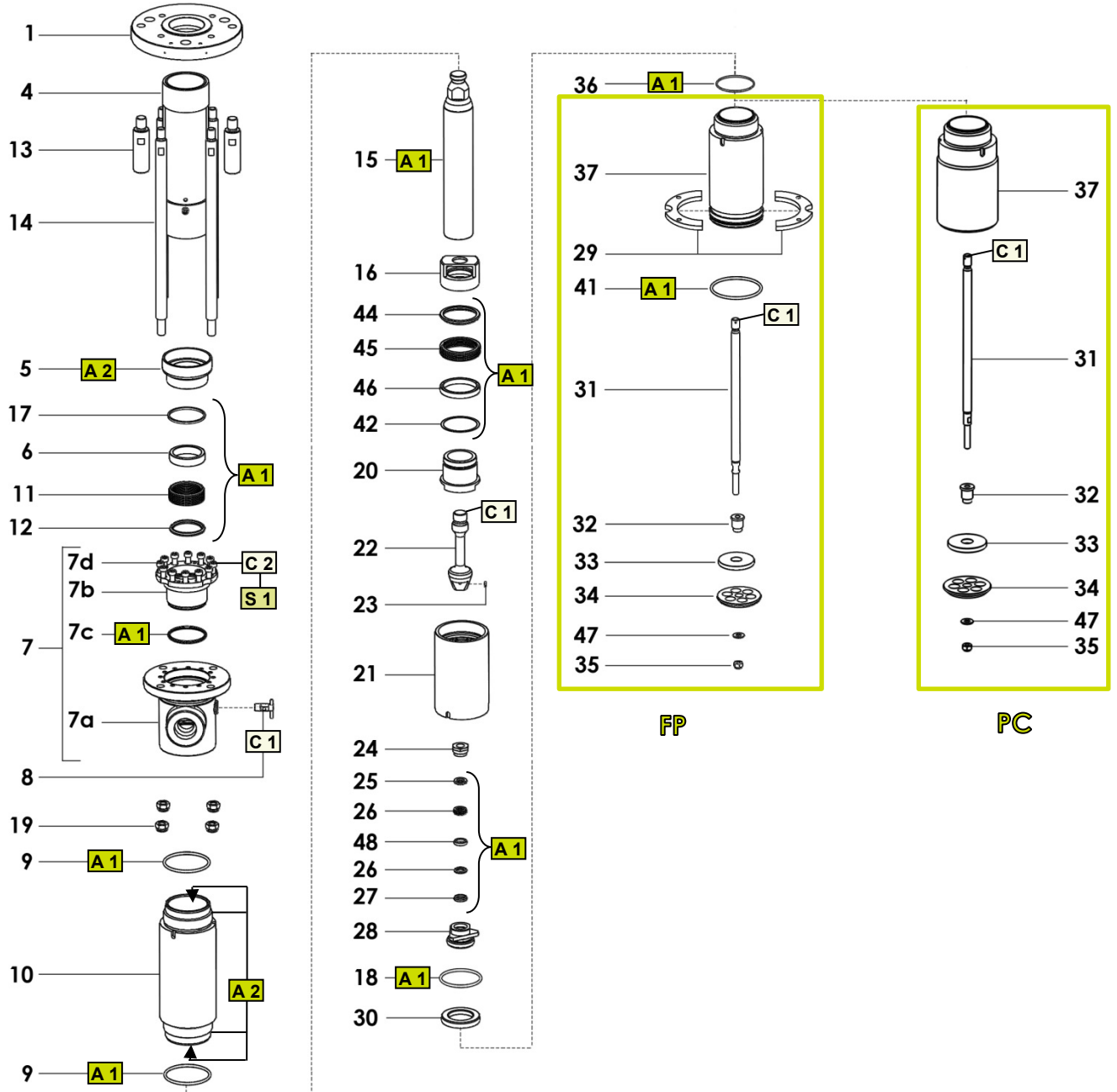

(For a full description of spare parts, see Part 12 - Spare Parts)

Disassembly of the pump

- ✓ Unscrew the nuts (19) and put aside the flange (1), the tie rods (14) and the protection (4),
 - ✓ Clamp the pump horizontally through the body (7) with a vice,
 - ✓ Unscrew the nut (35) and take off the shovel (34), the washer (33) and the spacer (32),
 - ✓ Unscrew the tube (37) and take off the seal (36),
 - ✓ Unscrew the valve body (21) and the outlet with the lower valve (28) and its seat (30),
 - ✓ Remove the piston / shovel rod assembly,
 - ✓ Unscrew the cylinder (10).
-

Cup seals

Nota: the pump body (7) consists of a cartridge (7b) to make easier the changing of the seals.

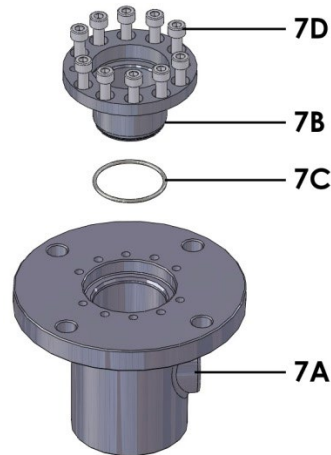

- ✓ Unscrew the cup (5),
- ✓ Take off the 12 screws (7d) that tighten the cartridge (7b) in the body (7a),
- ✓ Take off the cartridge (7b) screwing the extractors in the 3 M8 holes of the cartridge,
- ✓ Take off the washers (6 & 12) and the seals (11),
- ✓ Change the seals (11),
- ✓ Change the seal (7c).
- ✓ Clean and reinstall the parts in the reverse order of the disassembly sequence.

Lower valve

- ✓ Take off the seat (30) and the lower valve with the valve body (21),
- ✓ Unscrew the cup nut (24),
- ✓ Take off the male washer (25), the seals (26) and the female washer (27),
- ✓ Remove the seal (18),
- ✓ Clean and reinstall the parts in the reverse order of the disassembly sequence.

Upper valve

- ✓ Take off the pin (23) and unscrew the shovel rod (31),
 - ✓ Unscrew the piston valve (22),
 - ✓ Unscrew the piston bush (20) and take off the piston nut (16), the male washer (44), the piston seals (45) and the female washer (46).
 - ✓ Clean and reinstall the parts in the reverse order of the disassembly sequence.
-

Reassembly of the fluid section

- ✓ Lubricate the wetting cup seals and the piston head seals,
- ✓ Locate the seals (9) inside the pump body (7) of the valve body (21)
- ✓ Slide the piston rod assembly (15) inside the pump body (7), push it upwards;
- ✓ Screw the cylinder (10) to stop,
- ✓ Screw the shovel rod (31) change the pin (23),
- ✓ Screw the valve body (21) on the cylinder (10) to stop,
- ✓ Slide the lower valve (28) on the shovel rod (31) and screw slightly the cup nut (24),
- ✓ Install the seal (18) in the valve body (21),
- ✓ Install the seat (30) and push it in its housing,
- ✓ Locate the seal (36) inside the valve body (21),
- ✓ Screw the filling tube (37) to stop,
- ✓ Install the spacer (32), the washer (33) and the shovel (34) on the shovel rod (31),
- ✓ Screw the lock nut (35),
- ✓ Screw slightly the cup (5),
- ✓ Re assemble the pump to the pneumatic motor according to the instructions of the pump instruction manual.

Nota: The quantity of seals of the packings (11) & (45) depends upon the used package of seals.

Before each reassembly

- ✓ Clean the parts with the appropriate cleaning solvent.
 - ✓ Fit new seals if necessary, after greasing them.
 - ✓ Grease the piston and the inside of the cylinder to avoid damaging the seals.
 - ✓ Fit new parts if necessary.
-

12 Spare parts

Use only genuine **SAMES KREMLIN** accessories and spare parts designed to withstand the pump's operating pressures.

Fluid Section Follower Plate & Plain cylinder

REXSH0910-□-□-FP-□
REXSH0910-□-□-PC-□

WARNING: these parts are not supplied with the fluid section alone as they depend on the engine.

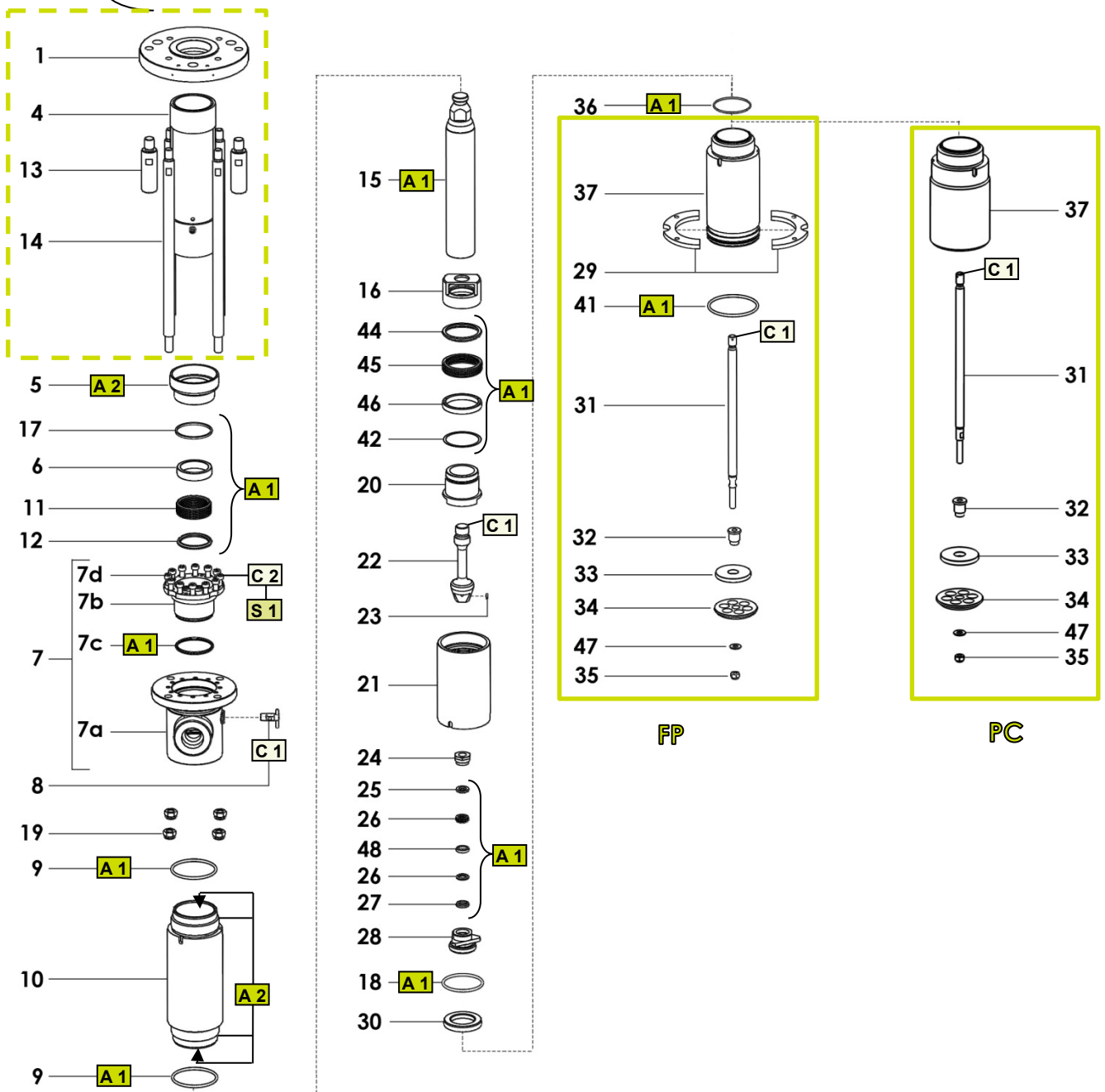

REXSH0910 - □ - □ - □ - □

FP	FP	PC
Follower Plate	Follower Plate	Plain Cylinder
CS	SS	CS
Mixed Steels	Stainless Steels	Mixed Steels

Ind.	Description	# Ref.			Qty	Spare part maintenance level**
**1	Connection flange	See motor coupling kit table			1	3
**4	Protection	See motor coupling kit table			1	3
5	Cup	210 700			1	3
7	Pump body	210 701			1	3
7a	Body	NS			1	3
7b	Cartridge	NS			1	3
7c	Seal	Refer to seals pack			1	1
7d	Screw, model CHc M 8x20	930 151 279			12	3
8	Drain valve	210 431			1	3
*10	Cylinder	210 718	210 901	210 718	1	2
13	Pin	See motor coupling kit table			2	3
**14	Tie-rod	See motor coupling kit table			4	3
*15	Piston rod	210 719	210 902	210 719	1	2
*16	Piston nut	210 716	210 899	210 716	1	3
*19	Lock nut	88 339			1	2
20	Piston bush	210 715	210 898	210 715	1	2
21	Valve body	210 717	210 900	210 717	1	3
23	Pin	88 429	88 575	88 429	1	3
24	Cup nut	60 120	60 219	60 120	1	3
28	Lower valve	210 679			1	2
29	Flange (2 parts)	210 686		-	1	3
*30	Seat	Refer to servicing kit			1	1
31	Shovel rod	210 692			1	3
32	Shovel spacer	210 682			1	3
33	Counter shovel	210 683	210 884	210 683	1	3
*34	Shovel	210 684	210 885	210 684	1	2
35	Lock nut	88 963			1	3
37	Filling tube	210 693	210 889	210 693	1	3

* Recommended maintenance parts.

**Level 1 : Preventive maintenance

N S: Denotes parts are not serviceable.

Level 2 : Corrective maintenance

Level 3 : Exceptional maintenance

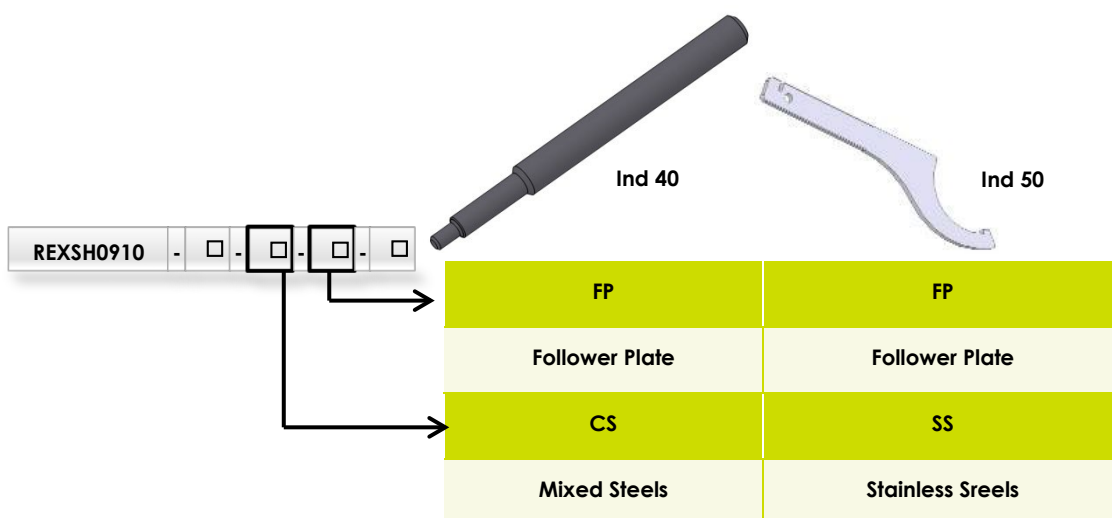

Ind.	Description	# Ref.	Qty	Spare part maintenance level**
40	Cup wrench	044 950 008	1	3
47	Washer	88 550	1	3
50	Wrench	210 946	1	3
*	Servicing kit Refer to table (Ind. 6, 9, 11, 17, 18, 26, 45, 48)	106 364 (Ind. 6, 12, 25, 27, 30, 44, 46, 48)	1	1

* Recommended maintenance parts.

**Level 1 : Preventive maintenance

N S: Denotes parts are not serviceable.

Level 2 : Corrective maintenance

Level 3 : Exceptional maintenance

Lower adapter flange

Ind.	Description	# Ref.	Qty	Spare part level**
-	Lower adapter flange for motors 7200 and 9200	144 245 497	1	3
-	▪Connecting flange assembly	N.S. (044 245 497)	1	
**1	▪ ▪ Connecting flange	N.S. (220 728 300)	1	
**2	▪ ▪ Screw CHc M18x55	N.S. (88 190)	3	
**13	▪ ▪ Pin	N.S. (209 582)	2	
**4	▪ Protective housing	N.S. (208 236)	1	
**14	▪Tie-rod	N.S. (203 169)	4	

* Recommended maintenance parts.

**Level 1 : Preventive maintenance

N S: Denotes parts are not serviceable.

Level 2 : Corrective maintenance

Level 3 : Exceptional maintenance

Servicing kit composition # 106 364

Ind.	Description	# Ref.	Qty	Spare part level**
6	'F' washer	210 730	1	1
12	'M' washer	210 731	1	1
25+27	'M' washer	211 333	2	1
30	Seat	210 680	1	1
44	'M' washer	210 712	1	1
46	'F' washer	210 713	1	1
48	'F' Spacer	60 220	1	1

**Level 1 : Preventive maintenance

Level 2 : Corrective maintenance

Level 3 : Exceptional maintenance

Seal kits recommended

Code	Composition	Use
01	PTFE (+ FKM)	Solvent - Ether - Ketone - Aromatic alcohol - some varnishes and paints
02	PTFE (+ FKM / FEP)	Solvent - Ether - Ketone - Aromatic alcohol - some varnishes and paints, PU paints - Pharmacy - Cosmetics - Some foodstuffs
03	PTFE + PE (+ FKM)	Epoxy glue - Butyl - Silicone - Some varnishes - Paint
04	PE + LEATHER (+ FKM)	Paint - Varnishes - Grease - Oil - Ink - Hydro soluble paint
05	GRAPHITED PTFE (+ FKM)	Paints - Varnishes - Inks - PVC compounds - Butyl
06	PU + GRAPHITED PTFE (+ FKM)	Mastics - PVC - Butyl
*07	PTFEV	Mastics - PVC - Butyl with a better temperature resistance
08	PEHD	UV ink

* Allows a better mechanical resistance

Accessory

Ind.	Description	# Ref.	Qty
-	Bottle of lubricant T (125 ml / 0,034 oz)	149 990 020	1

Seals packs composition: 04 to 06

Seals Pack: # :		04 106 334			05 106 335			06 106 336		
Ind.	Description	Qty	#	Material	Qty	#	Material	Qty	#	Material
9	O-Ring	2	84 456	FKM	2	84 456	FKM	2	84 456	FKM
11	Cup packing	4 3	210 722 210 723	PE LEATHER	9	210 603	PTFE G	5 1	84 395 210 722	PU PE
45	Piston packing	3 2	210 726 210 728	PE LEATHER	6	210 727	PTFE G	7	210 727	PTFE G
*36	O-Ring	1	84 448	PTFE	1	84 448	PTFE	1	84 391	PTFE
26	Shovel seal	4 2	211 334 211 335	PE PTFEV	4 2	211 334 211 335	PE PTFEV	4 2	209 726 209 725	PE PTFEV
41	O-Ring	1	84 457	FKM	1	84 457	FKM	1	84 457	FKM
42	Adjustment block	4*	210 729	ST STEEL	4*	210 729	ST STEEL	4*	210 729	ST STEEL
18	O-Ring	1	84 445	FKM	1	84 445	FKM	1	84 445	FKM
17	Ring	-			-			1	210 724	ST STEEL
7C	Cartridge seal	1	909 420 265	FKM	1	909 420 265	FKM	1	909 420 265	FKM

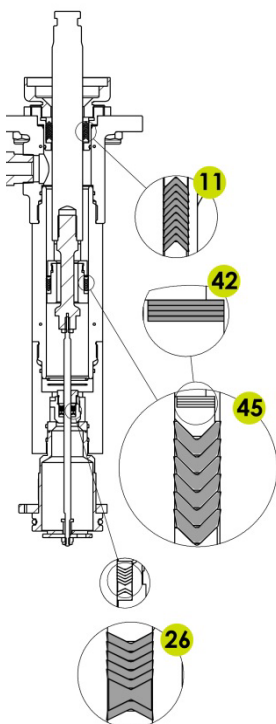

11	11	11
PE → ^	PTFE G → ^	Ring (l. 17) → □
LEATHER → ^	PTFE G → ^	PU → ^
PE → ^	PTFE G → ^	PU → ^
LEATHER → ^	PTFE G → ^	PU → ^
PE → ^	PTFE G → ^	PU → ^
LEATHER → ^	PTFE G → ^	PU → ^
PE → ^	PTFE G → ^	PE → ^
PE → ^	PTFE G → ^	PTFE G → ^
45	45	45
PE → v	PTFE G → v	PTFE G → v
LEATHER → v	PTFE G → v	PTFE G → v
PE → v	PTFE G → v	PTFE G → v
LEATHER → v	PTFE G → v	PTFE G → v
PE → v	PTFE G → v	PTFE G → v
PE → v	PTFE G → v	PTFE G → v
PE → v	PTFE G → v	PTFE G → v
26	26	26
PE → v	PE → v	PE → v
PTFE V → v	PTFE V → v	PTFE V → v
PE → v	PE → v	PE → v
PTFE V → v	PTFE V → v	PTFE V → v
PE → v	PE → v	PE → v
PE → ^	PE → ^	PE → ^

* Quantity to be assembled as required ** According to pump

PTFE G = Graphited PTFE

Seals packs composition: 07 and 08

Seals Pack: # :		07 107 301			08 106 575		
Ind.	Description	Qty	#	Material	Qty	#	Material
9	O-Ring	2	84 456	FKM	2	84 473	FKM
11	Cup packing	5	84 395	PU	1	211 278	PE
		1	210 722	PE	1	91 932	PTFE
45	Piston packing	3	210 726	PE	3	211 279	PE
		3	211 318	PTFE	3	91 931	PTFE
*36	O-Ring	1	84 448	PTFE	1	84 448	PTFE
26	Shovel seal	4	211 334	PE	1	211 280	PTFE
		2	211 335	PTFEV			
41	O-Ring	1	84 457	FKM	1	84 457	FKM
42	Adjustment block	4*	210 729	ST STEEL	-		
18	O-Ring	1	84 445	FKM	1	84 472	FKM
7C	Cartridge seal	1	909 420 265	FKM	1	909 420 265	FKM

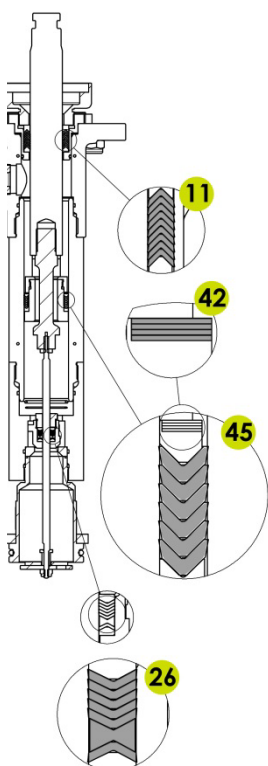

11			11		
PU			PE	→	□
PU	→	^	PTFE	→	□
PU	→	^			
PU	→	^			
PU	→	^			
PE	→	^			
45			45		
PTFE	→	v	PE	→	□
PE	→	v	PTFE	→	□
PTFE	→	v			
PE	→	v			
PTFE	→	v			
PE	→	v			
26			26		
PE	→	v	PE	→	□
PTFE V	→	v			
PE	→	v			
PTFE V	→	v			
PE	→	v			
PE	→	^			

* Quantity to be assembled as required ** According to pump