

AIRMIX® 15C25 & 30C25 PUMP SPARE PARTS BREAKDOWN

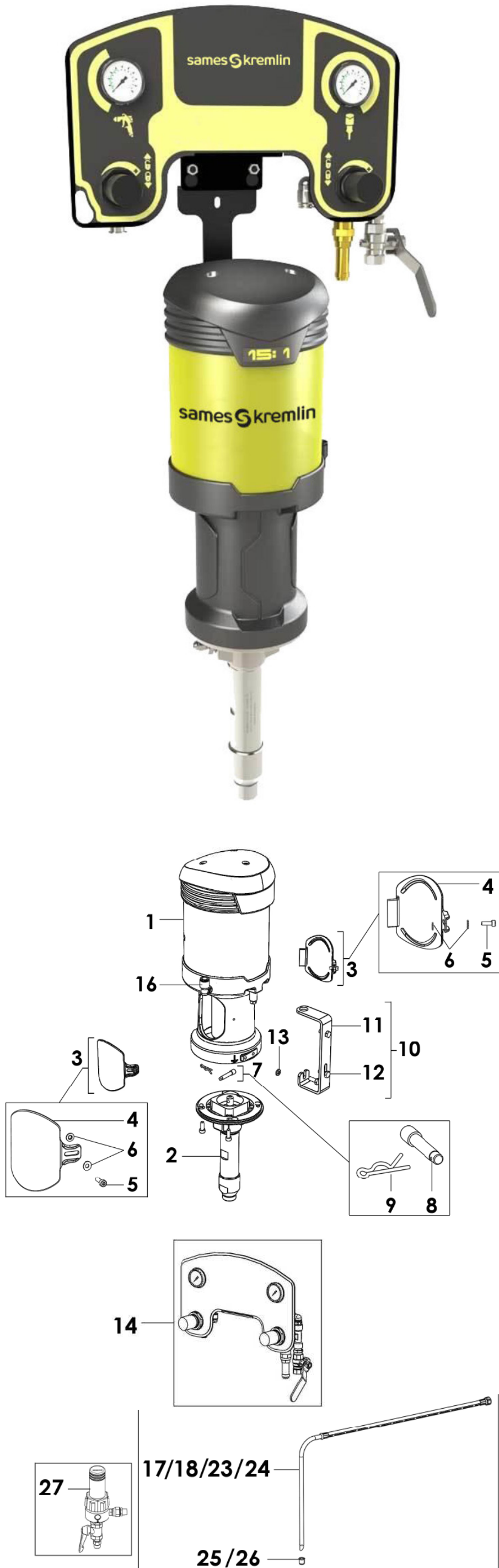

REF	DESCRIPTION	P/N	QTY
	Airmix® 15C25 Pump wall mounted without suction rod	151-140-000	1
	Airmix® 30C25 Pump wall mounted without suction rod	151-145-000	1
	Airmix® 15C25 Pump wall mounted with suction rod Ø 16	151-140-100	1
	Airmix® 30C25 Pump wall mounted with suction rod Ø 16	151-145-100	1
	Airmix® 15C25 Pump wall mounted with suction rod Ø 16 and fluid filter Ø 3/8"	151-140-150	1
	Airmix® 30C25 Pump wall mounted with suction rod Ø 16 and fluid filter Ø 3/8"	151-145-200	1
1	Air motor, model 245-4 (Airmix® 15C25)	NS	1
1	Air motor, model 420-4 (Airmix® 30C25)	NS	1
*2	Fluid section, model C25 (Material inlet M 26 x125)	144-130-200	1
*3	Coupling housing kit	144-130-013	1
4	Coupling housing kit	NS	2
5	Screw	NS	2
6	Washer	NS	4
*7	Coupling kit	144-130-019	1
8	Axe	NS	1
9	Pin	NS	2
*10	Pump bracket	144-130-022	1
11	Pump bracket	NS	1
12	Screw, model H 6x16	NS	3
13	Washer, model AZ6	NS	1
-	Nuts, screws & tie-rods kit	144-130-195	1
-	Nut	-	4
-	Screw	-	8
-	Tie-rod, connecting	-	4
*14	Air supply	151-140-050	1
16	Elbow connector 1/4G - T 8x10	905-120-913	1
17	Suction rod Ø 16 - (Airmix® 15C25)	149-596-050	1
18	Suction rod Ø 25 - (Airmix® 30C25)	149-596-150	1
23	Suction rod Ø 16 for drum, model 200 L	149-596-060	1
24	Suction rod Ø 25 for drum, model 200 L	149-596-160	1
25	Strainer Ø 16	149-596-052	1
26	Strainer Ø 25	149-596-152	1
27	Fluid filter, model Ø 3/8"	155-580-600	1
-	Air hose (Ø 7 x 13 mm - 25 ft / 7.5 m)	82-2725-00	1
-	Hose sleeve 25 ft (7.5m)	669-990-102	1
-	Xcite® Airmix™ gun 120 bar and swivel fitting	135-720-100	1
-	Xcite® Airmix™ gun 200 bar and swivel fitting	135-720-200	1
-	Airmix® hose Ø 4.8mm (25 ft / 7.5 m)	050-450-605	1
31	Gravity cup 1.6 gal (6 L)	151-140-230	1
-	Cup	NS	1
-	U adapter	NS	1
32	Screen, 18 mesh (pack of 2)	151-890-399	1
-	Lubricant T 4.4 oz (125 ml)	149-990-020	1

NS = Not Serviceable part / * = Suggested Spare part

BOND • PROTECT • BEAUTIFY

AIRMIX® 15C25 & 30C25 PUMP

SPARE PARTS BREAKDOWN

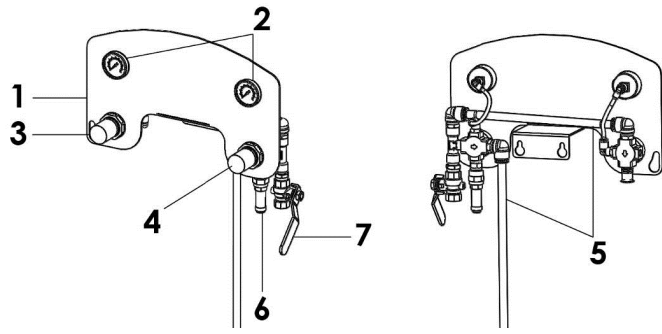

AIR SUPPLY

REF	DESCRIPTION	P/N	QTY
	Air supply for Airmix® Pump	151-140-050	1
1	Bracket, air supply	151-140-055	1
2	Gauge, model 0-87 psi (0-60 bar)	910-011-205	2
3	Air regulator, model 1/4 gun	151-140-051	1
4	Air regulator, model 1/4 pump	151-140-052	1
5	Hose, model 8 x 10 length 10" (0.25 m)	050-372-125	1
6	Discharge valve	903-080-401	1
7	Valve, model F 3/8	903-090-209	1

AIR MOTOR

REF	DESCRIPTION	P/N	QTY
*1	Cover assembly	144-130-016	1
2	Cover	NS	1
3	Screw, model CHc 6x25"	933-151-332	3
4	Muffler	144-130-011	1
*5	Cover	144-130-004	1
6	Screw, model CHc 6x45	933-151-523	3
7	Seal O-Ring, model Ø 50	909-420-220	1
8	Valve	144-130-010	1
9	Nut, model HM6	953-010-016	4
10	Exhaust grid	144-130-024	1
*11	Reversing body	144-130-003	1
12	Seal	909-210-501	1
13	Seal holder	144-130-008	1
16	Tie-rod	144-130-012	4
19	Control rod assembly	144-130-006	1
*20	Spring (pack of 2)	144-130-194	1
21	Seal O-Ring, model Ø 13	909-130-315	1
22	Coupling screw	144-130-020	1
23	Muffler	NS	1
24	NBR seal (black)	000-940-120	6

REF	DESCRIPTION	P/N	QTY
25	Pin	144-130-023	1
27	Tube, connecting	144-130-014	3
29	Plug (pack of 5)	144-130-192	1
30	Cable, ground (Length: 16.5ft (5m))	901-180-024	1
Specific parts to the air motor, model 245-4			
14a	Seal, cylinder	909-420-305	1
15a	Air cylinder	144-140-002	1
17a	Air piston	144-140-003	1
18a	Seal, model Ø 62 (air piston)	909-130-438	1
26a	U seal, model Ø 64	909-210-404	1
28a	Motor flange	144-140-001	1
Specific parts to the air motor, model 420-4			
14b	Seal, cylinder	909-420-304	1
15b	Air cylinder	144-130-009	1
17b	Air piston	144-130-002	1
18b	Seal, model Ø 45 (air piston)	909-130-447	1
26b	U seal, model Ø 75	909-210-403	1
28b	Motor flange	144-130-001	1
*	Servicing kit - Motor 245-4 (Ref. 7, 8, 12, 14a, 18a, 20, 21, 24, 26a)	144-140-190	1
*	Servicing kit - Motor 420-4 (Ref. 7, 8, 12, 14b, 18b, 20, 21, 24, 26b)	144-130-190	1
*	Reversing kit (Ref. 7, 8, 12, 13)	144-130-191	1

NS = Not Serviceable part / * = Suggested Spare part

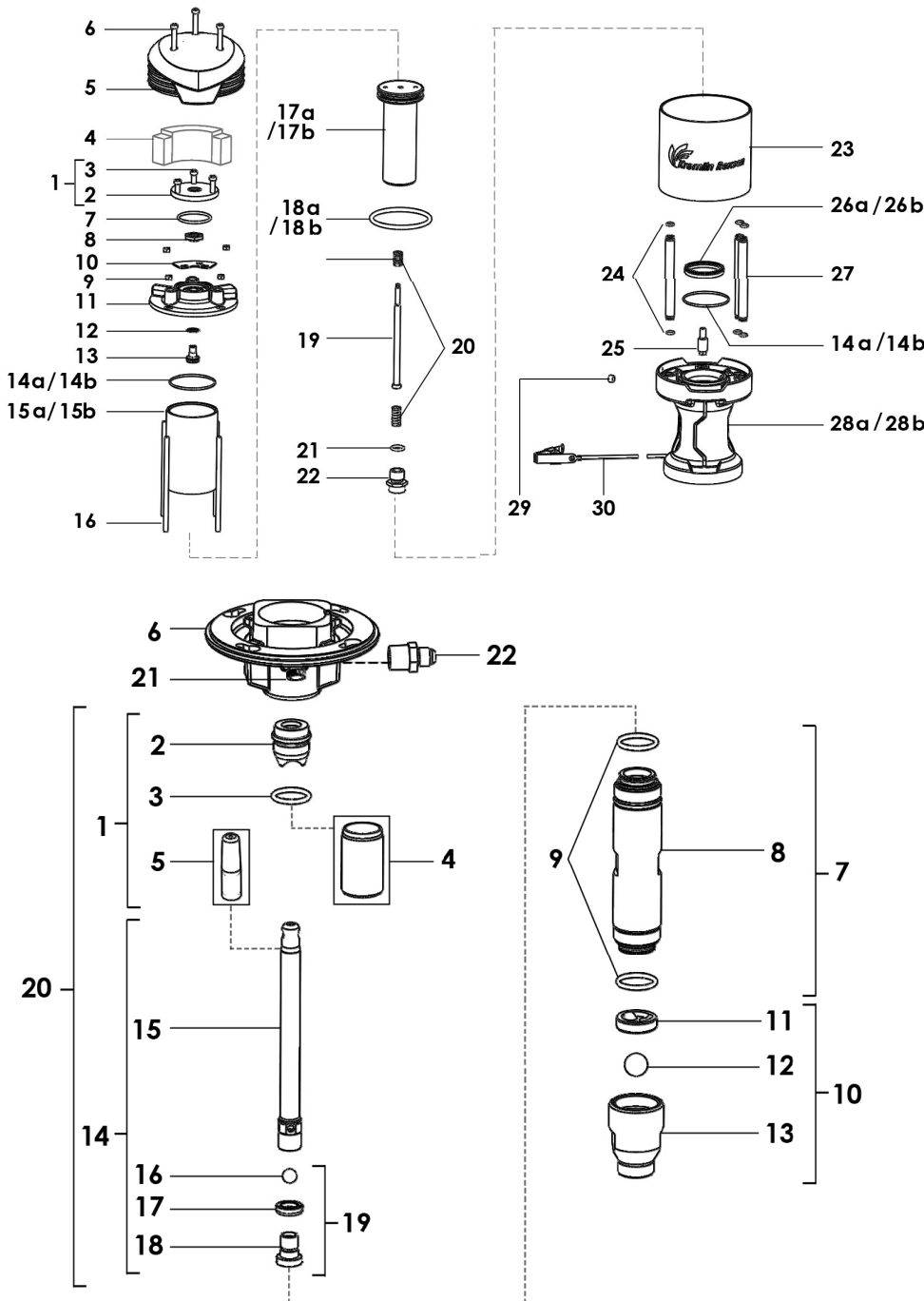

FLUID SECTION

REF	DESCRIPTION	P/N	QTY
*1	Cartridge kit	144-130-205	1
2	Cartridge(stainless steel)	NS	1
3	Seal (pack of 5)	150-040-339	1
4	Tool for cartridge assembly	NS	1
5	Tool for packing assembly	NS	1
6	Outlet flange	144-130-294	1
*7	Cylinder (Ref. 8) + seal (ind. 9)	144-130-202	1
8	Cylinder	144-130-296	1
9	O-Ring PTFE (x 10)	150-040-315	2
*10	Suction valve assembly M 26 x125 (Ref. 11, 12, 13)	144-130-208	1
11	Ball stop (x 4)	144-130-209	1
12	Ball Ø 16 (stainless steel)	907-414-242	1
13	Pump foot M 26x125	144-130-399	1
*14	Piston assembly (ind. 15, 16, 17, 18)	144-130-213	1
15	Piston	NS	1
16	Ball, model Ø 9.52 (440 C stainless steel)	907-414-223	1
17	GT seal	144-130-299	1
18	Seat	144-130-298	1
*19	"Exhaust valve kit (Ref. 16, 17, 18)"	144-130-204	1
*20	"Cartridge and piston kit (Ref. 1, 14)"	144-130-289	1
21	Drain plug (x 5)	144-130-193	1
22	Adapter, stainless steel, double male, 3/8 NPT - # 5 JIC (1/2 JIC)	905-210-503	1
*	Servicing kit (Ref. 9, 12, 16, 17)	144-130-291	1
*-	Tool kit (Ref. 4, 5)	144-130-297	

LT 999-600-173 ©2023 Sames reserves the right to change without notice characteristics and services offered as well as equipment and attachments of these.