

DOCUMENTATION

PUMP 65F260

AIRLESS

Manual : 582.010.110-UK - 2403

Date: 12/03/24

Supersede : 04/08/22

Modif.: Update

TRANSLATION FROM THE ORIGINAL MANUAL

IMPORTANT : Before assembly and start-up, please read and clearly understand all the documents relating to this equipment (professional use only).

THE PICTURES AND DRAWINGS ARE NON CONTRACTUAL. WE RESERVE THE RIGHT TO MAKE CHANGES WITHOUT PRIOR NOTICE.

SAMES KREMLIN SAS

13, chemin de Malacher
38 240 - MEYLAN - France

 : 33 (0)4 76 41 60 60

www.sames-kremlin.com



DECLARATION OF INCORPORATION
OF PARTLY COMPLETED MACHINERY
EU DECLARATION OF CONFORMITY

(1) The manufacturer herewith declares that the equipment is in conformity with the relevant Union harmonization legislation.

(2) Equipment type	FLOWMAX AIRLESS PUMP 65F260		
(3) Applicable Directives	2006/42/CE	(4) The relevant technical documentation was compiled as specified in annex VII, part B.	
		The essential health and safety requirements mentioned in the Directive 2006/42/CE on Machinery have been applied. Articles: 1.1 , 1.1.2 ,1.1.3, 1.1.5 , 1.2 , 1.2.2, 1.2.3, 1.2.4, 1.2.4.1 , 1.2.4.3 , 1.2.6, 1.3 ,1.3.1, 1.3.2, 1.3.3, 1.3.4, 1.3.6, 1.3.7, 1.3.9, 1.4,1.4.1,1.4.2, 1.4.2.1, 1.5, 1.5.2, 1.5.3, 1.5.4, 1.5.5, 1.5.6, 1.5.7, 1.5.8, 1.6, 1.6.1 , 1.6.2, 1.6.3, 1.6.4, 1.7, 1.7.1, 1.7.2	
	(5) That partly completed machinery is also in conformity with the provisions of		
	2014/34/UE	(6) Marking	FLOWMAX AIRLESS PUMP 65F260 ⊕ II 2G Ex h IIB T5 Gb X FLOWMAX AIRLESS PUMPS RANGE ⊕ II 2G Ex h IIB T1-T6 Gb X Ex h => Protection par sécurité deconstruction (c) / Protection by constructional safety (c) Conditions spéciales d'utilisation, le signe X indique de se référer aux prescriptions figurant dans le manuel d'instructions qui accompagnent le produit. - Specific conditions of use, X indicates to refer to the prescriptions specified in the instructions manual that accompanies the product.
	(7) Harmonised standards	EN ISO 80079-36 : 2016 EN ISO 80079-37 : 2016 EN 1127-1 : 2019	
	(8) Conformity assessment procedure	Module A Technical documentation (Annex VIII)	
(9) Notified body	INERIS 0080 – 60550 Verneuil-en-Halatte – France – INERIS-EQEN		
(10) This partly completed machinery must not be put into service until the final machinery in which it is to be incorporated has been declared in conformity with Directive 2006/42/CE on Machinery. Sames is allowed to compile the technical documentation. Sames undertakes to transmit, in response to a reasoned request by the national authorities, relevant information on the partly completed machinery in the most appropriate form. This declaration of incorporation of partly completed machinery and this declaration of conformity are issued under the sole responsibility of the manufacturer.			

Director of the STAINS site - Executive Management (EM)

Hervé WALTER

Established in Stains, on 05th March 2024

DocuSigned by:

Herve Walter

361F833E514C4D1...

SAMES

Siège Social / Headquarter: 13, chemin de Malacher - CS70086 - 38243 Meylan Cedex - France - Tél / Phone: +33 (0)4 76 41 60 60

SAS au capital de 12.720.000 euros | RCS Grenoble: 572 051 688 | Code APE: 2829B | TVA intracom: FR36 572051688



Table with 2 columns: Numbered items (1-10) and their corresponding descriptions in multiple languages (French, Greek, Italian, Spanish, Polish, Czech, etc.) regarding CE marking and technical documentation for machinery.



DECLARATION OF INCORPORATION
OF PARTLY COMPLETED MACHINERY
UK DECLARATION OF CONFORMITY

(1) The manufacturer herewith declares that the equipment is in conformity with the UK statutory requirements.

(2) Equipment type	FLOWMAX AIRLESS PUMP 65F260		
(3) Applicable Directives	2008 No. 1597	(4) The relevant technical documentation was compiled as specified in annex VII, part B.	
		The essential health and safety requirements mentioned in Supply of Machinery (Safety) Regulations 2008 have been applied. Articles: 1.1 , 1.1.2 ,1.1.3, 1.1.5 , 1.2 , 1.2.2, 1.2.3, 1.2.4, 1.2.4.1 , 1.2.4.3 , 1.2.6, 1.3 ,1.3.1, 1.3.2, 1.3.3, 1.3.4, 1.3.6, 1.3.7, 1.3.9, 1.4,1.4.1,1.4.2, 1.4.2.1, 1.5, 1.5.2, 1.5.3, 1.5.4, 1.5.5, 1.5.6, 1.5.7, 1.5.8, 1.6, 1.6.1 , 1.6.2, 1.6.3, 1.6.4, 1.7, 1.7.1, 1.7.2	
	(5) That partly completed machinery is also in conformity with the provisions of		
	2016 No. 1107	(6) Marking	FLOWMAX AIRLESS PUMP 65F260 ⊕ II 2G Ex h IIB T5 Gb X FLOWMAX AIRLESS PUMPS RANGE ⊕ II 2G Ex h IIB T1-T6 Gb X Ex h => Protection par sécurité deconstruction (c) / Protection by constructional safety (c) Conditions spéciales d'utilisation, le signe X indique de se référer aux prescriptions figurant dans le manuel d'instructions qui accompagnent le produit. - Specific conditions of use, X indicates to refer to the prescriptions specified in the instructions manual that accompanies the product.
		(7) Designated standards	EN ISO 80079-36 : 2016 EN ISO 80079-37 : 2016 EN 1127-1 : 2019
		(8) Conformity assessment procedure	Module A Technical documentation (Annex VIII)
(9) Approved body		CML 2503 - Ellesmere Port - United Kingdom	
(10) This partly completed machinery must not be put into service until the final machinery in which it is to be incorporated has been declared in conformity with Supply of Machinery (Safety) Regulations 2008. Sames is allowed to compile the technical documentation. Sames undertakes to transmit, in response to a reasoned request by the national authorities, relevant information on the partly completed machinery in the most appropriate form. This declaration of incorporation of partly completed machinery and this declaration of conformity are issued under the sole responsibility of the manufacturer.			

Director of the STAINS site - Executive Management (EM)

Hervé WALTER

Established in Stains, on 05th March 2024

DocuSigned by:

Herve Walter

361F833E514C4D1...



INSTALLATION AND SAFETY INSTRUCTIONS

TRANSLATION FROM THE ORIGINAL MANUAL

IMPORTANT : Before assembly and start-up, please read and clearly understand all the documents relating to this equipment (professional use only).

THE PICTURES AND DRAWINGS ARE NON CONTRACTUAL. WE RESERVE THE RIGHT TO MAKE CHANGES WITHOUT PRIOR NOTICE.

SAMES KREMLIN SAS
13, chemin de Malacher
38 240 - MEYLAN - France
☎ : 33 (0)4 76 41 60 60

www.sames-kremlin.com

1. SAFETY INSTRUCTIONS

GENERAL SAFETY INSTRUCTIONS



CAUTION : The equipment can be dangerous if you do not follow our instructions concerning installation and servicing described in this manual and in accordance with applicable European standards and local national safety regulations.

Please carefully read all the instruction literature before operating your equipment.

Only trained operators can use the equipment.

The foreman must ensure that the operator has understood the safety instructions for this equipment as well as the instructions in the manuals for the different parts and accessories.

Read carefully all instruction manuals, label markings before operating the equipment.

Incorrect use may result in injury. This equipment is for professional use only. It must be used only for what it has been designed for. Never modify the equipment. The parts and accessories supplied must be regularly inspected. Defective or worn parts must be replaced.

Guards (motor cover, coupling shields, connectors,...) have been designed for a safe use of the equipment.
The manufacturer will not be held responsible for bodily injury or failure and / or property damage due to destruction, the overshadowing or the partial or total removal of the guards.

Never exceed the equipment components' maximum working pressure.

Comply with regulations concerning safety, fire risks, electrical regulations in force in the country of final destination of the material. Use only products or solvent compatible with the parts in contact with the material (refer to data sheet of the material manufacturer).

PICTOGRAMS

A	D	F	E	C	G
NIP HAZARD	WARNING MOVING ELEVATOR	WARNING MOVING PARTS	WARNING MOVING SHOVEL	DO NOT EXCEED THIS PRESSURE	HIGH PRESSURE HAZARD
H	J	L	K	M	Q
RELIEF OR DRAIN VALVE	WARNING HOSE UNDER PRESSURE	WEAR GLASSES OBLIGATORY	WEAR OF GLOVES IS OBLIGATORY	PRODUCT VAPOR HAZARDS	WARNING HOT PARTS OR AREAS
N	P	R	S	T	U
ELECTRICAL HAZARD	WARNING FIRE HAZARDS	EXPLOSION HAZARDS	GROUNDING	WARNING (USER)	WARNING SERIOUS INJURIES

PRESSURE HAZARDS



Current legislation requires that an **air relief** valve be fitted in the air supply circuit to the air motor to prevent over pressurisation. This safety feature, ensures that it is not possible to supply the air motor with excessive air pressure that may cause injury.

Please ensure that a **material drain valve** is fitted in the fluid circuit to drain and depressurise the circuit. Once depressurised and drained, work /servicing may then commence on the equipment. Please remember to close these valves when restarting the system.

HIGH PRESSURE INJECTION HAZARDS



When working with high pressure equipment, special care is required. Fluid leaks can occur. There is a risk of material being injected to any exposed parts of body, this could cause severe injury :

- medical care must be sought immediately if paint is injected under the skin or in other parts of the body (eyes, fingers).
- never point the spray gun at any one. Never try to stop the spray with your hands or fingers nor with rags or similars.
- **follow the shut down procedure and always depressurize air and fluid circuits** before carrying out any servicing on the gun (cleaning, checking, maintenance of the material or cleaning of the gun nozzles).
- for the guns equipped with a safety device, always lock the trigger when not in use.

FIRE - EXPLOSION - SPARKS - STATIC ELECTRICITY HAZARDS



A poor earth connection, inadequate ventilation, sparks or static electricity can cause an explosion or fire. to avoid these risks when using or servicing SAMES KREMLIN equipment, the following safety procedures must be followed :

- ensure a good earth connection and ground the parts to be handled i.e. solvents, materials, components and equipment,
- ensure adequate ventilation,
- keep working area clean and free from waste solvents, chemicals, or solid waste i.e. rags, paper and empty chemicals drums,
- never use electrical switches / power if in an atmosphere of volatile solvent vapour,
- stop working immediately in case of electrical arcs,
- never store chemicals and solvents in the working area.
- use paint whose flash point is the highest possible to prevent from any formation of gas and inflammable vapours (refer to materials' safety instructions),
- install a cover on the drums to reduce the diffusion of gas and vapours in the spraybooth.

TOXIC PRODUCT HAZARDS



Toxic products or vapours can cause severe injury not only though contact with the body, but also if the products are ingested or inhaled. It is imperative :

- to know the material products and their risks,
- notified or hazardous materials must be stored in accordance with the regulations,
- the material must be stored in an appropriate container, never place materials in a container where there is a risk of spillage or leakage,
- a procedure must be applied for the safe disposal of waste material. It must comply with all prevailing regulations and legislations of the country where the equipment is to be used,
- protective clothing should always be worn in compliance with the material manufacturers' recommendations,
- depending on the application and chemical safety instructions, safety glasses, hearing protective earplug, gloves, foot wear, protective masks and possible breathing equipment should be worn to comply with the regulations (Refer to chapter "Safety equipment of SAMES KREMLIN selection guide).



CAUTION!

It is forbidden to use material containing high concentrations of halogenated hydrocarbon solvents with **aluminium** or **zinc fillers**. Non-compliance with the instructions may cause explosion risk causing serious or fatal injury.



EQUIPMENT REQUIREMENTS

Guards (motor cover, coupling shields, connectors,...) have been designed for a safe use of the equipment.

The manufacturer will not be held responsible for bodily injury or failure and / or property damage due to destruction, the overshadowing or the partial or total removal of the guards.



PUMP

Before carrying out any work, it is imperative to read and clearly understand the disassembly and reassembly instructions before servicing. The operator must understand the equipment and the safety instructions. These instructions are available in the equipment manuals.

The air motor is designed to be mounted with a pump. Never modify any components or couplings. When operating, please keep hands away from moving parts. Before starting up the equipment, please read the PRESSURE RELIEF instructions. Please ensure that any relief or drain valves fitted are in good working order.

HOSES

- Keep hoses out of circulation areas, moving parts or hot surfaces,
- Never expose product hoses to temperature higher than + 60°C / 140° F or lower than 0°C / 32° F,
- Never pull or use the hoses to move the equipment,
- Tighten all fittings as well as the hoses before operating the equipment,
- Check the hoses regularly; change them if they are damaged,
- Never exceed the maximum working pressure (MWP) indicated on the hose.

USED PRODUCTS

Considering the wide variety of products that are available and can be used in our equipment it is impossible to check and make recommendations for all chemical data, regarding the risks of possible chemical attack and their long term chemical reaction

SAMES KREMLIN can not be held liable for :

- compatibility of wetted parts,
- risks to staff and the surroundings,
- for worn or defective parts, for faulty equipment or units, or the quality of final product.

It is the responsibility of the user to know and prevent any possible risks such as toxic vapours, fires or explosions. He shall determine the risks of immediate reactions or pursuant to repeated exposures of the staff,

SAMES KREMLIN shall not be liable for physical injuries, direct or indirect material damages caused by the use of chemicals.

2. HANDLING

 **Check the weight and the dimensions of the equipment**
(☞ refer to 'Technical features' section of the instruction manual)

If weight and dimensions are too important, the unloading must be carried out by means of a forklift or any other appropriate means with a qualified personnel and in a clear horizontal area to prevent from risks of damage injury or an accident.

The centre of gravity is not in the centre of the machine : carry out by hand a stability-test after having lifted the whole at 10 cm / 3.937" maximum.

After the unloading, the handling of the whole (eg: elevator pump) is carried out by means of a pallet truck taking the bottom part of the frame.

Remark : Each pump motor is fitted with a ring. The ring is designed for the hoisting of one pump and can not be used for the handling of the complete assembly.

3. STORING

Storing before installation :

- Storing ambient temperature : 0 / +50 °C / 0 / +122°F
- Protect the whole against dust, water trickling, dampness and shocks.

Storing after installation :

- Operating temperature : +15 / +35 °C / +59 / +138.2° F
- Protect the whole against dust, water tricking, dampness and shocks.

4. INSTALLATION OF THE EQUIPMENT

The machine is installed on a stable horizontal floor (for eg a concrete flag).

The machine shall be made stable by the use of holding down bolts or by the use of other anchoring methods, strong enough to prevent unintended bodily movement of the equipment.



To avoid risks caused by static electricity, the equipment as well as its components must be grounded.

- **For the pumping equipments** (pumps, pneumatic rams, frame...), a section wire of 2.5 mm² is fixed on the material. Use this wire to connect the material to "the general ground". In case of severe environments (mechanical protection of the wire of earthing insufficient, vibrations, mobile material...) where function damages at the ground are probable, the user have to replace the provided wire of 2.5 mm² by a device more adapted to its environment (wire with a more important section, bonding strip, fixing by thimble with eyelet...).

The continuity of the ground must be controlled by a qualified electrician. If the continuity of the ground is not ensured, check the terminal, the wire and the earthing point. **Never** use the material without have solved this problem.

- In the severe cases of environments (mechanical protection of the wire of earthing insufficient, vibrations, mobile material...) where damages of the function put at the ground are probable, the user will have to replace the wire of 2.5 mm² provided, by a device more adapted to its environment (wire of more important section, bonding strip, fixing by thimble with eyelet...),
- **The gun** must be 'grounded' via a material hose or an air hose. In case of spraying by means of a gun with cup, the air hose must be conductive,
- **The materials to be painted** must also be grounded.

All the materials situated in the working area shall be grounded.



- **Never store** more than necessary inflammable materials inside the working area,
- The materials must be stored into **approved drums** and grounded,
- Use only grounded **metals containers** for the use of cleaning solvents,
- **Cardboard and paper are prohibited.**

5. MARKING OF THE EQUIPMENT

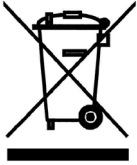

Each equipment has a label plate with the name of the manufacturer, the equipment part number, the interesting informations to use correctly the equipment (pressure, voltage,...) and sometimes the above pictogram.

The equipment is designed with and consists of high quality materials and components which can be re-used.

The 2012/19/UE European Directive covers all equipments with a crossed-out bin pictogram. Please inform yourself about the collection systems for electric and electronic equipments.

Please act in accordance with local rules and **do not dispose of old equipment with household wastes**. A correct disposal of old equipment will help prevent negative consequences for the environment and health.

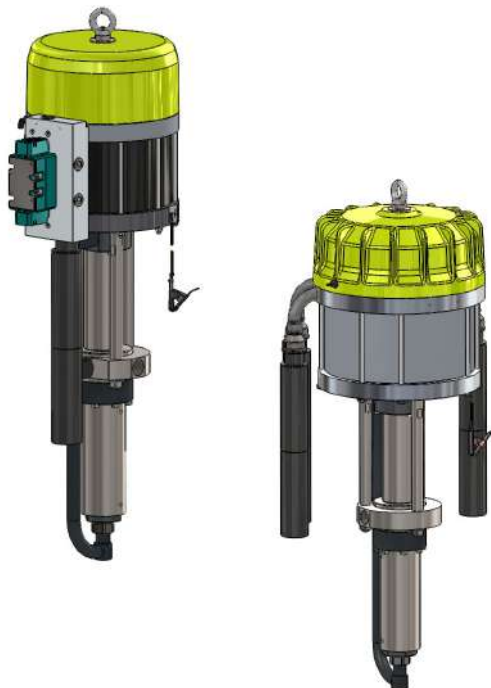

AIRLESS FLOWMAX® PUMPS

40F260

65F260

Disassembly / Reassembly

TRANSLATION FROM THE ORIGINAL MANUAL

IMPORTANT : Before assembly and start-up, please read and clearly understand all the documents relating to the equipment (professional use only).

THE PICTURES AND DRAWINGS ARE NOT CONTRACTUAL. WE RESERVE THE RIGHT TO MAKE CHANGES WITHOUT PRIOR NOTICE.

SAMES KREMLIN SAS
13, chemin de Malacher
38 240 - MEYLAN - France
☎ : 33 (0)4 76 41 60 60

www.sames-kremlin.com



CAUTION :

Before any action on the pump, shut off the compressed air supply and depressurize the system.

The pump is manufactured under the ATEX agreement and can not be modified. SAMES KREMLIN will not be held responsible for any failure to comply with that instruction.

- **FLUID MOTOR OR AIR MOTOR REPLACEMENT (REFER TO DOC. 573.407.050 & 573.410.050)**

**Guards (air motor cover, coupling shields, housings ...) have been designed for safe use of the equipment.
The manufacturer will not be held responsible for bodily injury or failure and / or damage to property due to removal or partial removal of the guards**

To remove a component of the pump :

- Disassemble all the accessories of the pump (rods, filter), if it necessary.
- Put aside the pump, if it is necessary (the pump is fitted with an hoisting ring).

Before removing the B sub-assembly or the A sub-assembly, you must remove the connecting rod (41). For that :

- Unscrew the nut fitting (38) and the screws (43 & 45),
- Remove the connecting rod (41).

The fluid section of the pump consists of 2 sub-assemblies :

- the upper part (bellows suction sub-assembly : A)



- the lower part (fluid sub-assembly : B)



This sub-assembly is more frequently service than the A sub-assembly.

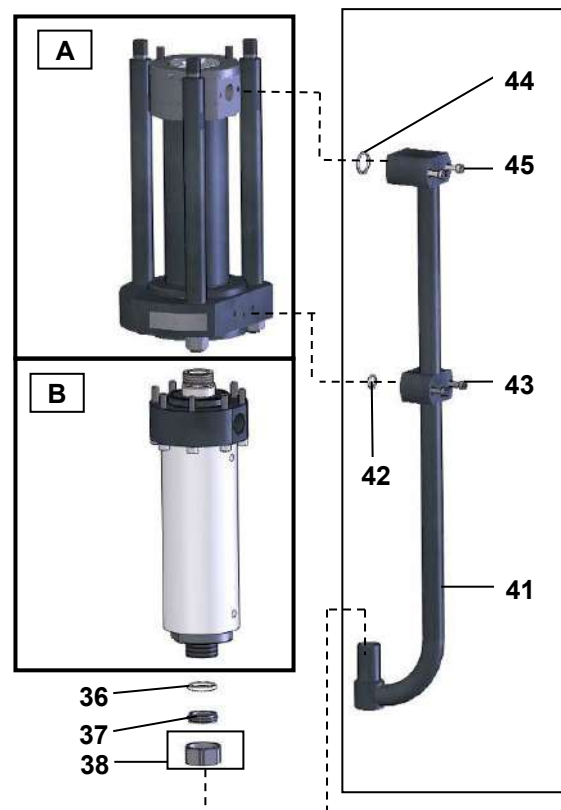

DISASSEMBLY / REASSEMBLY OF THE FLUID SECTION

Guards (air motor cover, coupling shields, housings ...) have been designed for safe use of the equipment.

The manufacturer will not be held responsible for bodily injury or failure and / or damage to property due to removal or partial removal of the guards

DISASSEMBLY / ASSEMBLY OF THE FLUID SUB-ASSEMBLY (B)

Nota : The suction valve, the cylinder, the exhaust valve and the upper GT-seal are dismantled and change without needing to separate the fluid sub-assembly (B) from the suction sub-assembly (A).

■ SUCTION VALVE (30)

Disassembly

Unscrew the suction valve (30).

Nota : If the cylinder (21) remains attached to the suction valve, unscrew both parts, then hold cylinder (21) by inserting a rod into the cylinder holes designed for this purpose.

The ball (32) is secured on the valve (31) by means of a circlips (33).

Clean the parts with the appropriate cleaning solvent.

Assembly

Reinstall the ball (32) and the circlips (33) on the suction valve body (31).

Change the seal (13). Lubricate it.

⚠ Lubricate the threading of the valve body.

Reinstall valve assembly (30) on the cylinder (21).

■ CYLINDER (21)

In order to make easier the disassembly, a hole is drilled in the cylinder (21) at each end.

Depending on the part that it is unscrewed first, insert a rod into one of these holes to unscrew the other part.

When reassembling, make sure the two seals (13) are installed. Lubricate them.

⚠ Lubricate the inside of the cylinder (grease, type A1) and the tappings to prevent from damaging the mobile packing (grease, type A2) (refer to assembly instructions §).

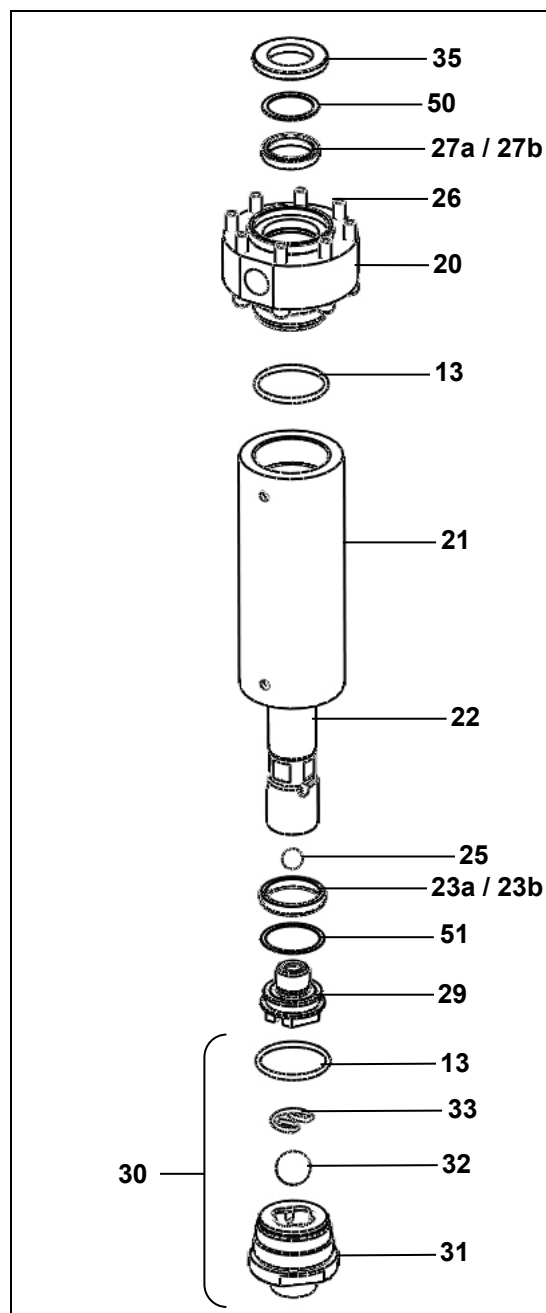

▪ **EXHAUST VALVE (29) AND MOBILE PACKING (23A/23B)**

Disassembly

Unscrew the cylinder (21) and pull it downwards.

Unscrew the exhaust valve (29) with a flat wrench n° 46 by holding the piston (22).

Remove the ball (28), the washer (6c) and the mobile packing (seal - 23a/23b).

Clean the parts.

Assembly

Install a new seal (23a/23b). Lubricate it.

➤ **Comply with the seal (23a/23b) installation order.**

Install the ball (25) on the exhaust valve (29).

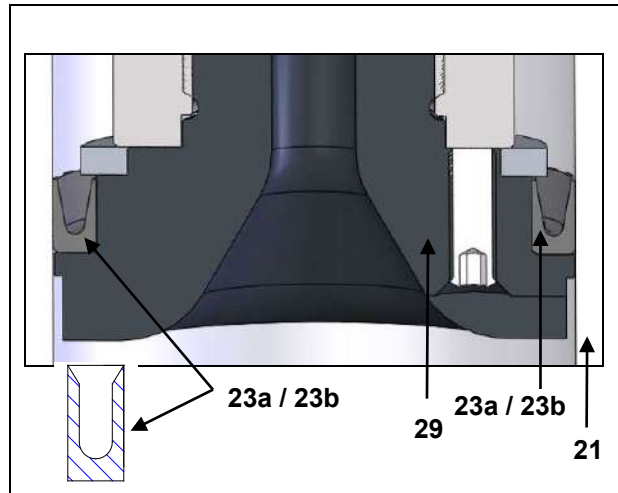

⚠ Lubricate the threading of the exhaust valve (grease, type A2).

Screw the whole on the piston lower part (22).

DISASSEMBLY / ASSEMBLY OF THE BELLOWS SUCTION SUB-ASSEMBLY (A)

The disassembling of the upper tightness seal and of the bellows requires to separate the the fluid sub-assembly (B) from the suction sub-assembly (A).

SEPARATION PROCEDURE

Disassemble the cylinder (21). You can see the fluid section piston (22).

➤ You must place the piston downwards.

⚠ install an air pressure (from 0.2 to 0.5 bar / from 2.9 to 7.2 psi) on the air motor to make the piston (22) get down. When the piston is at its lower point, close the air inlet valve to prevent the piston from getting up.

Remove the 3 nuts (11), the washers (12).

Pull the suction flange (1) downwards, you can see the skirt (6).

Nota: The cylinder (2) must keep assemble with the suction bearing (3).

Unscrew slightly the 3 screws (9) to give play on the bellows (5).

Unscrew the skirt (6) (tools : 41 mm / 1.6" wrench).

Nota :To make easier the disassembly of the skirt, you can remove one of the 3 pump tie-rods (7).

⚠ **Caution : the skirt must be visible.**

By means of the 2 wrenches, to separate the piston (22) from the motor rod (40M) by using the flats on the motor rod and those on the base of the piston.

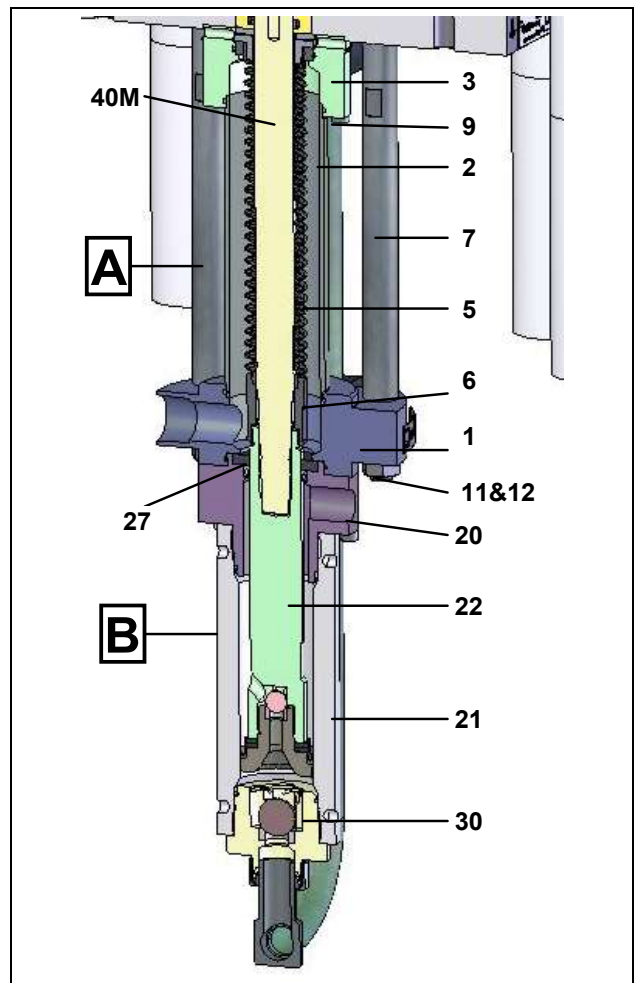

COUPLING PROCEDURE

 Change the seals (8 & 24) and lubricate them.

Clean the threading of the motor rod (40M) and the tapping of the pump piston (22).
Make the air motor rod get down (see the previous paragraph).

 **Apply a light coating glue to the threading of the motor rod (Loctite 222).**

Place the exhaust flange-fluid section piston assembly.

Screw the motor rod into the fluid section.

 **Apply a light coating of glue to the pump piston threading (Loctite 5772).**

➤ **Pull the skirt (6) downwards, then screw it on the fluid section piston (22).**
(tool : 41 mm / 1.6" wrench).

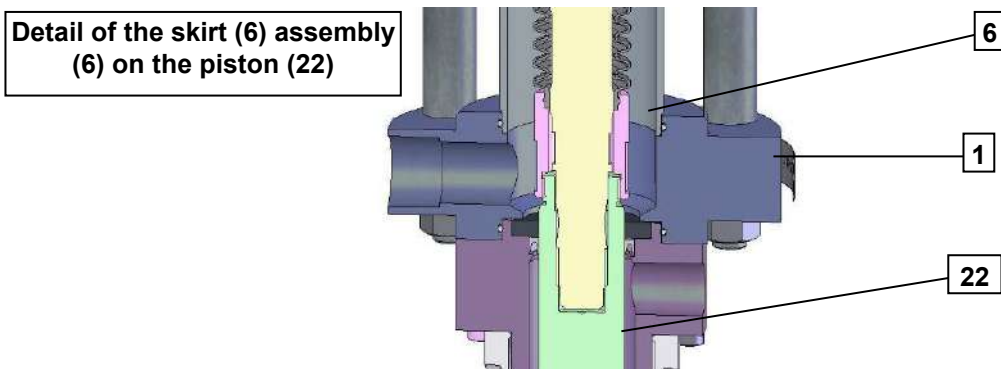

Reinstall the tie-rod (7) if you removed it.

Reinstall the suction flange (1).

Tighten the 3 screws (9).

Place the 3 washers and tighten the nuts (11).

Reinstall the lower part of the pump (cylinder, suction valve, suction rod,...) in the reverse order of the disassembly sequence, as explained previously.

■ **UPPER TIGHTNESS SEAL (27A/27B)**

Disassembly

Unscrew the 8 screws (26)

Separate the fluid sub-assembly (A) from the suction sub-assembly (B)

Remove the upper ring (35).

Remove the GT seal (27a/27b) by pulling the exhaust flange (20) downwards.

Remove the o-ring seals (8 & 24) which are on the suction flange.

Assembly

 Place the seal (27a/27b) in the exhaust flange (20) after having lubricated it.

➤ **Comply with the seal (27a/27b) installation order.**

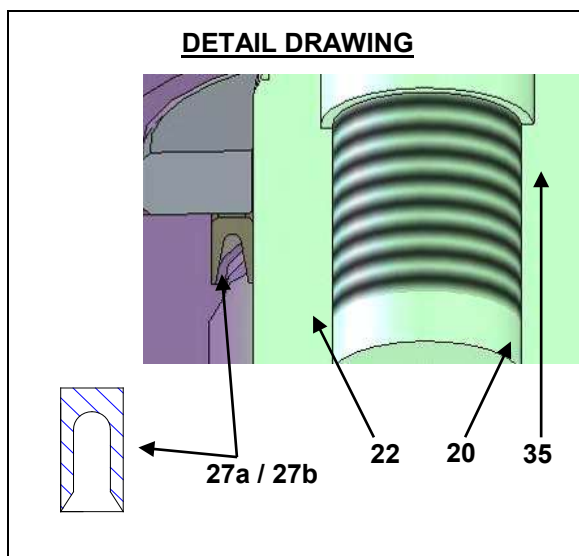

Place the upper part of the piston (22) on the cone shaped tool (refer to above drawing).

 Grease the cone shaped tool.

Slide the piston-cone shaped tool into the exhaust flange (20), from downwards to upwards.

Slide the GT seal on the whole (the tool prevents from damaging the seal when assembling the piston).

Remove the tool when it is above the flange (20).

Install the upper ring (35).

Change the seal (8) and tighten the 8 screws (26).

Couple the fluid sub-assembly (B) with the suction sub-assembly (A).



■ BELLOWS

This operation must be done after the separation of the lower part from the upper part of the fluid section and after the dismantling of the upper tightness seal.

In the work table, prepare assembly, which consists of fluid section piston-exhaust flange while following the procedure of the upper tightness seal (27a/27b).

Disassembly

Remove the bearing (3) from the cylinder (2).

Separate the suction bearing (3) from the motor by removing the screws (9).

Slide, then put aside the bellows-skirt-flange assembly.

Remove the bellows flange (4) to take off the upper part of the bellows.

Dismount the skirt (6).

Assembly

To prepare an assembly, which consists of bellows-skirt-flange, you must :

- Install a new bellows (5) into the bellows flange (4).
- Change the seal (13).

 Lubricate the seal (13) and the flange (4) (grease, type A1).

- Insert the assembly in the bearing (3).
- When installing the bellows, push it into skirt (6) firmly.
- Install the upper bellows flange (14).

Slide the bellows-skirt-flange assembly along the air motor rod.

Orientate it and tighten it on the air motor base by means of the 3 screws (9).

Nota :To make easier the assembly, you can remove one of the 3 pump tie-rods (7).

Couple the fluid sub-assembly (B) with the suction sub-assembly (A).

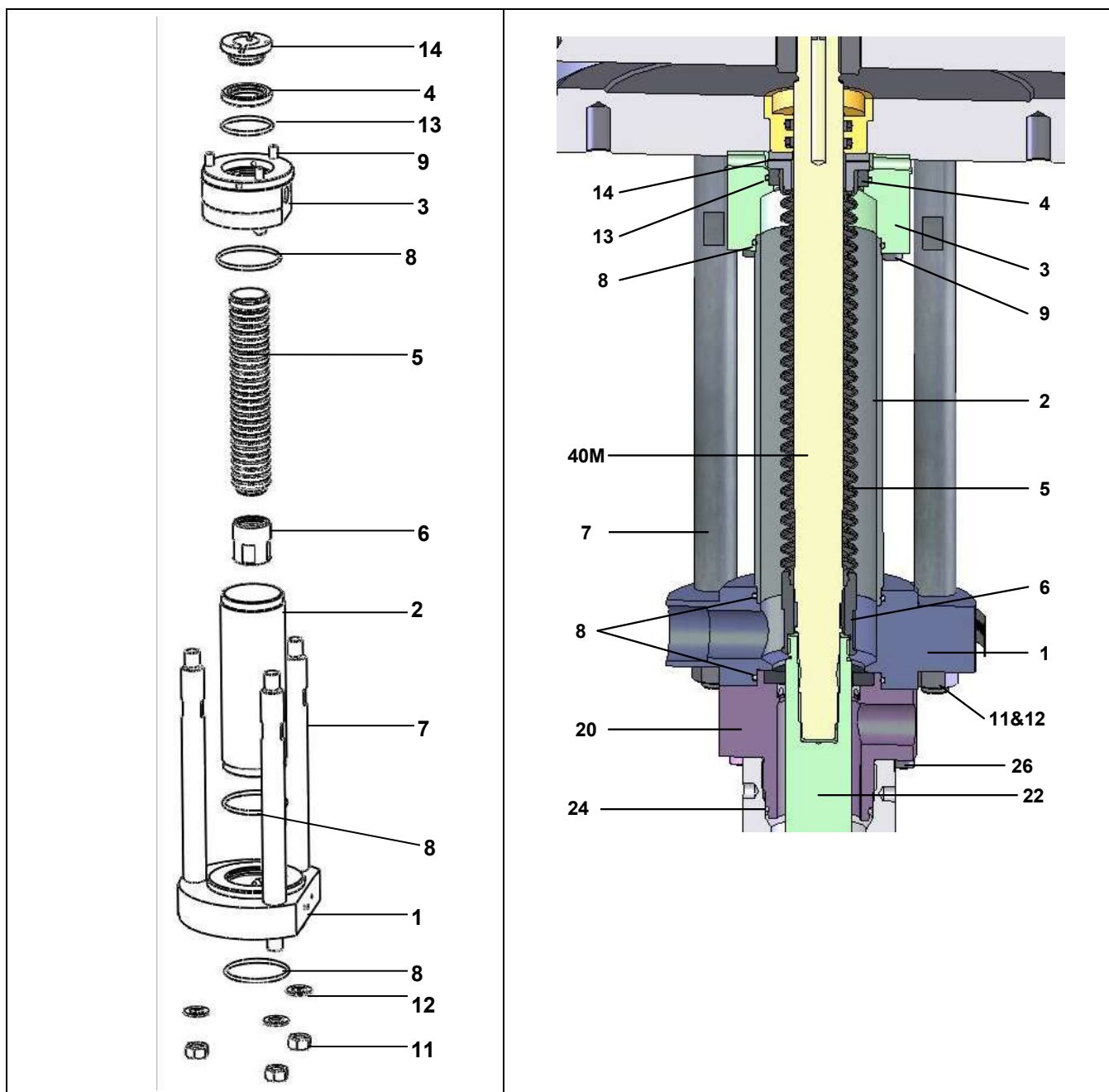

AIR MOTOR

▪ MOTOR REVERSING BLOCK (REFER TO DOC. 573.087.040)

**Guards (air motor cover, coupling shields, housings ...) have been designed for safe use of the equipment.
The manufacturer will not be held responsible for bodily injury or failure and / or damage to property due to removal or partial removal of the guards**

Disassemble the air motor cover (6 or 31) by removing the nut (4 or 33).

Dissociate the female yoke (14 or 27) from the reversing block lever (9 or 10).

Dismount the reversing -block by removing the screws (11 or 28).

Reinstall the new reversing-block in the reverse order of the disassembly sequence.

- ⇒ **CAUTION** : the number of spirals must equally be distributed on each fastening parts in order to get the above dimension.

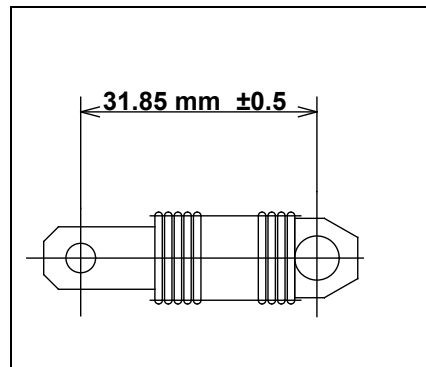

Before reassembling the different components :

- Clean the parts with the appropriate cleaning solvent.
- Install new seals if it is necessary, after having lubricated them with PTFE grease.
- Lubricate the piston and the inside of the cylinder to prevent from damaging the seals.
- Install new parts if it is necessary.

▪ DEGREES OF WEAR

The wetted parts in contact with the material are subject to wear with time. It depends, of course, on the rates and duration of pump operating; also on the material handled.

Under normal operating and servicing conditions, with standard filled material not including foreign matters or chemically aggressive, the average working life can be estimated as :

- **1 million strokes for the tightness seals.**
- **10 millions strokes for the bellows.**

ASSEMBLY INSTRUCTIONS

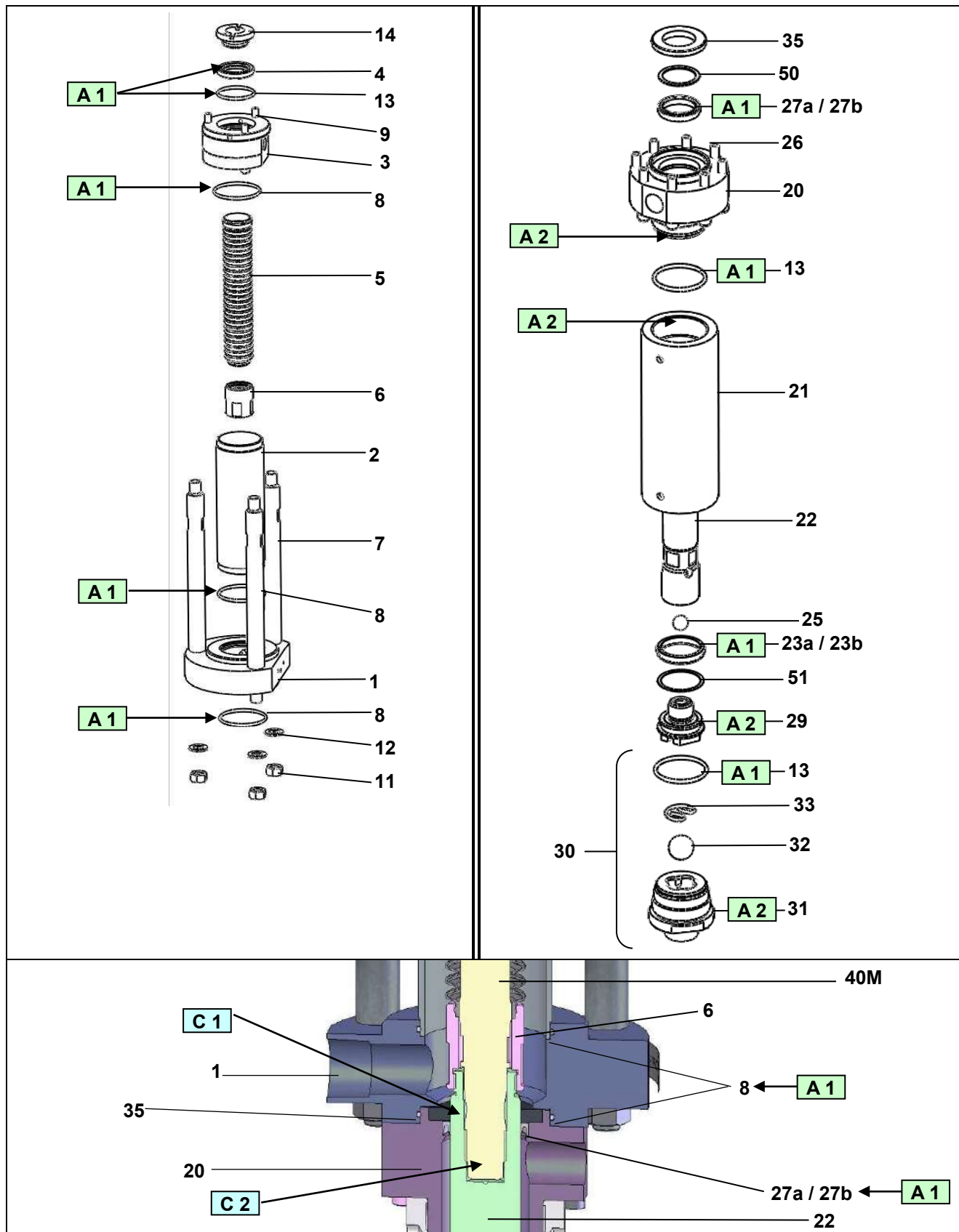

Index	Instruction	Description	Part number
A 1	PTFE grease	'TECHNILUB' grease (10 ml / 0.0026 US gal)	560.440.101
A 2	Anti-seize grease	Grease box (450 g / 0.99 lb)	560.420.005
C 1	Medium strength Aneorobic Pipe sealant	Loctite 5772 (50 ml / 0.013 US gal)	554.180.015
C 2	Low strength - Aneorobic Adhesive	Loctite 222 (50 ml / 0.013 US gal)	554.180.010

Doc. 573.407.050 Date/Datum/Fecha : 05/08/22 Annule/Cancela/ Ersetzt/Anula : 30/11/18	Modif. / Änderung : Ind. / Pos. 16	Pièces de rechange Spare parts list Ersatzteilliste Piezas de repuesto
---	--	---

POMPE FLOWMAX® AIRLESS®, modèle 65F260	FLOWMAX® AIRLESS PUMP, model 65F260
FLOWMAX® AIRLESS PUMPE, Modell 65F260	BOMBA FLOWMAX® AIRLESS, tipo 65F260

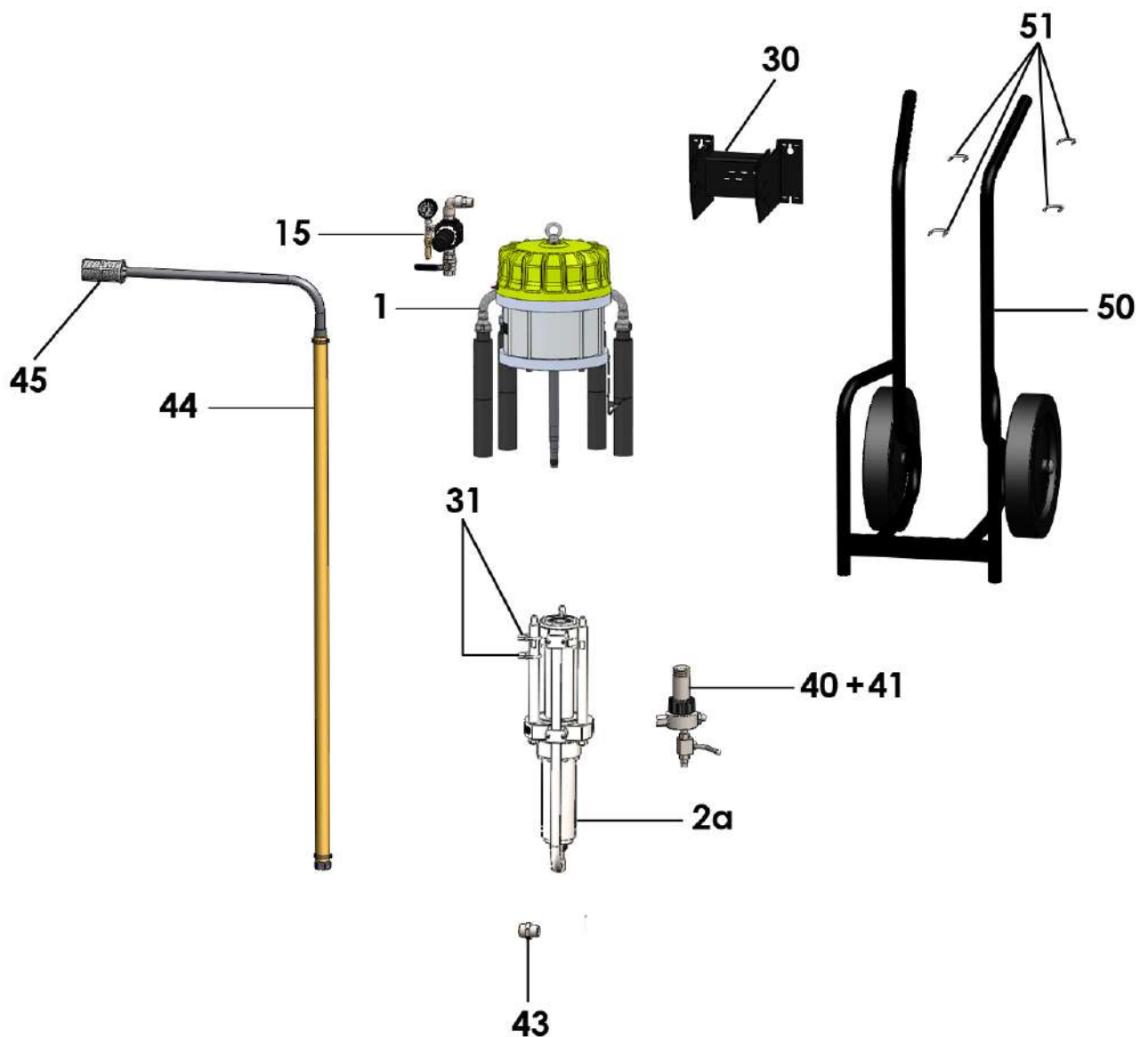

POMPE MURALE, modèle 65F260 avec canne d'aspiration et filtre	WALL MOUNTED PUMP, model 65F260 with suction rod and filter	#
WANDANLAGE, Modell 65F260 mit Saugschlauch und Filter	BOMBA MURAL, tipo 65F260 con caña de aspiración y filtro	151.881.600

Ind	#	Désignation	Description	Bezeichnung	Denominación	Qté
-	NC / NS	Pompe murale	Wall mounted pump	Wandanlage	Bomba mural	1
*1	146 254 000	▪ Moteur 8000.4_2 (voir Doc. 573.408.050)	▪ Air motor, model 8000.4_2 (refer to Doc. 573.408.050)	▪ Luftmotor, 8000.4_2 (siehe Dok. 573.408.050)	▪ Motor, tipo 8000.4_2 (consultar Doc. 573.408.050)	1
*2a	NC / NS	▪ Hydraulique F260 inox (voir Doc. 573.409.050)	▪ Fluid section, model F260 (stainless steel) (refer to Doc. 573.409.050)	▪ Hydraulikteil, F260 Edelstahl (siehe Dok. 573.409.050)	▪ Hidráulica, tipo F260 de inox (consultar Doc. 573.409.050)	1
15	-	Equipement d'air (voir page 5)	Air supply equipment (refer to page 5)	Luftausrüstung (siehe Seite 5)	Equipo de aire (consultar página 5)	1
30	051 341 206	Support de pompe	Pump bracket	Wandhalterung	Soporte de bomba	1
31	NC / NS	Etrier avec rondelles et écrous	U-bolt with washers and nuts	Schelle mit Scheiben und Muttern	Tirante con arandelas y tuercas	3
40	155 581 400	Filtre 3/4 équipé (voir Doc. 573.327.050)	Filter, model 3/4 equipped (refer to Doc. 573.327.050)	Ausgerüsteter Filter, Modell 3/4 (siehe Dok. 573.327.050)	Filtro, tipo 3/4 equipado (consultar Doc. 573.327.050)	1
*41	000 161 112	▪ Tamis n° 12 (280 µ)	▪ Screen n° 12 (280 µ)	▪ Sieb Nr 12 (280 µ)	▪ Tamiz n° 12 (280 µ)	1
43	050 102 449	Raccord inox MM 1" - 38 x 150	Fitting, model double male, 1" - 38 x 150 (stainless steel)	Doppelnippel, Edelstahl AG 1" - M 38 x 1,50 AG	Racor de inox, tipo MM 1" - 38 x 150	1
44	049 597 100	Canne d'aspiration inox (Ø 25) avec crépine	Suction rod (stainless steel) with strainer	Saugschlauch mit Siebkorb (Rohr in ES)	Caña de aspiración (inox) con piña	1
*45	149 591 400	▪ Crépine avec manchon	▪ Strainer with sleeve	▪ Siebkorb mit Buchse	▪ Piña con manguito	1

POMPE SUR CHARIOT, modèle 65F260	CART MOUNTED PUMP, model 65F260	#
PUMPE 65F260 FAHRBAR	BOMBA 65F260 SOBRE CARRETILLA	151.881.700

Ind	#	Désignation	Description	Bezeichnung	Denominación	Qté
-	151 881 600	Pompe murale avec canne d'aspiration et filtre	Wall mounted pump with suction rod and filter	Wandanlage mit Saugschlauch und Filter	Bomba mural con caña de aspiración y filtro	1
50	051 231 000	Chariot	Cart	Fahrgestell	Carretilla	1
*51	151 730 114	Pochette 2 étriers, 4 rondelles, 4 écrous	Pack of 2 u-bolts, 4 washers, 4 nuts	Satz mit 2 Schellen, 4 Scheiben, 4 Muttern	Bolsa de 2 tirantes, 4 arandelas, 4 tuercas	2

EQUIPEMENT D'AIR (ind. 15)	AIR SUPPLY EQUIPMENT (ind. 15)
LUFTAUSRÜSTUNG (Pos. 15)	EQUIPO DE AIRE (ind. 15)

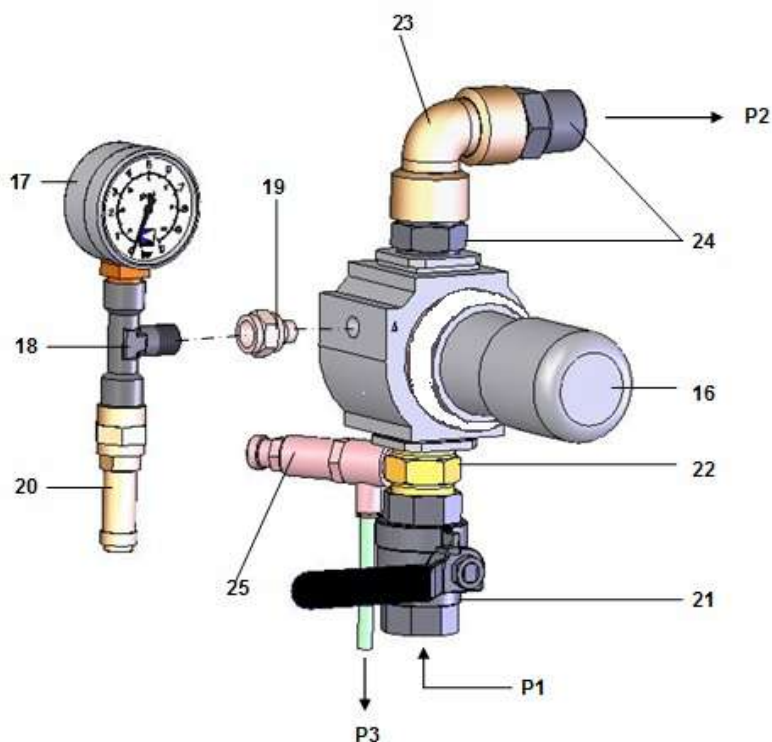

Ind	#	Désignation	Description	Bezeichnung	Denominación	Qté
*16	016 480 000	Détendeur d'air 3/4 0 - 10 bar (volant phosphore)	Air regulator, model 3/4 0 - 10 bar / 0 - 145 psi (phosphorous knob)	Druckminderer, 3/4 0 - 10 bar (phosphor Stellglocke)	Manorreductor, tipo 3/4 0 - 10 bar (pomo fósforo)	1
*17	910 011 402	Manomètre 0 - 10 bar	Gauge, model 0 - 10 bar / 0 - 145 psi	Manometer 0 - 10 bar	Manómetro, tipo 0 - 10 bar	1
18	552 441	Té 1/4"	Tee, model 1/4"	T-Stück, 1/4"	Té, tipo 1/4"	1
19	552 491	Raccord F 1/4" - M 1/8"	Fitting, model F 1/4" - M 1/8"	Nippel, IG 1/4" - AG 1/8"	Racor, tipo H 1/4" - M 1/8"	1
20	903 080 401	Soupape de décharge	Discharge-valve	Sicherheitsventil	Válvula de seguridad	1
21	903 090 208	Robinet F 3/4	Valve, F 3/4	Absperrhahn, IG 3/4	Grifo, tipo H 3/4	1
22	051 870 151	Raccord MM 3/4 BSP avec piquage	Fitting, model double male, 3/4 BSP	Doppelnippel AG 3/4 BSP	Racor, tipo MM 3/4 BSP	1
23	552 429	Coude FF 3/4"	Elbow, model FF 3/4"	Winkelnippel IG 3/4"	Codo, tipo HH 3/4"	1
24	050 102 215	Raccord MM 3/4 BSP	Fitting, model double male, 3/4 BSP	Doppelnippel AG 3/4 BSP	Racor, tipo MM 3/4 BSP	2
25	903 130 508	Régulateur de pression	Pressure air regulator	Druckreduzierventil	Regulador de presión	1

* Pièces de maintenance préconisées.

* Preceding the index number denotes a suggested spare part.

* Bezeichnete Teile sind empfohlene Ersatzteile.

* Piezas de mantenimiento preventivas.

N C : Non commercialisé.

N S : Denotes parts are not serviceable.

N S : Bezeichnete Teile gibt es nicht einzeln, sondern nur komplett .

N S : no suministrado.

Réglage / Adjustment / Einstellung / Ajuste

P1 = 6 bar max. / 87 psi max.

(arrivée air général / main air inlet / Hauptluft Eingang / llegada aire general)

P2 = 1 → 5,5 bar / 14.5 → 80 psi

(air de puissance / power air / Arbeitsluft / aire de potencia)

P3 = 4 bar max. / 58 psi max.

(air de pilotage / pilot air / Steuerluft / aire de pilotaje)

Le régulateur (25) est préréglé en usine pour délivrer une pression de 4 bar max.

The regulator (25) is preset in the factory to give a maximum pressure of 4 bar / 58 psi.

Der Druckregler (25) ist werksseitig auf einen maximalen Steuerluftdruck von 4 bar eingestellt.

El regulador (25) se regula en la fábrica para suministrar una presión máxima de 4 bar.

ACCESSOIRES - ACCESSORIES - ZUBEHÖR - ACCESORIOS



Ind	#	Désignation	Description	Bezeichnung	Denominación	Qté
53	051 881 459	Flamme : outillage pour montage garniture	Piston rod starter tool	Konus zur Montage der Packung	Herramienta para montar guarnición	1

Doc. 573.408.050 Date/Datum/Fecha : 19/12/18 Annule/Cancela/ Ersetzt/Anula : 18/08/16	Modif. / Änderung : # 044 630 400 → NC (ind. 9a / Pos. 9a) + # 144 630 720 (ind. 9b / Pos. 9b)	Pièces de rechange Spare parts list Ersatzteilliste Piezas de repuesto
---	---	---

MOTEUR A AIR, modèle 8000-4_2	AIR MOTOR, model 8000-4_2	#
LUFTMOTOR, Modell 8000-4_2	MOTOR DE AIRE, tipo 8000-4_2	146.254.000

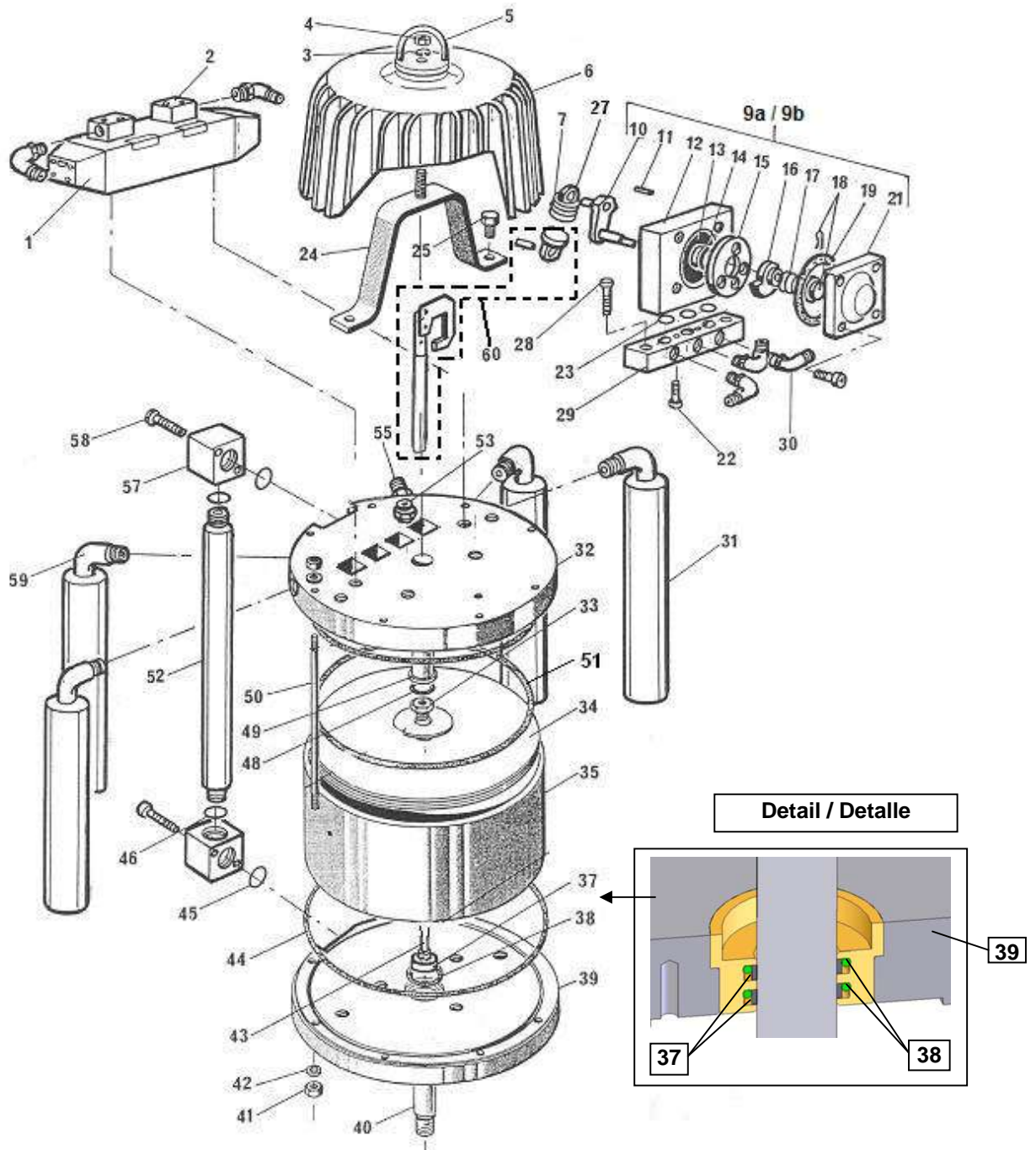

Ind	#	Désignation	Description	Bezeichnung	Denominación	Qté
1	903 050 483	Distributeur	Distributor	Luftverteiler	Distributor	1
2	046 250 009	Embase pilote	Base, distributor	Steuerblock	Base piloto	2
3	NC / NS	Rondelle d'appui	Support washer	Scheibe	Arandela de soporte	1
4	953 010 023	Ecrou HM 12	Nut, model HM 12	Mutter, M 12	Tuerca, tipo HM 12	1
5	91 422	Anneau de levage	Ring, cover	Ringschraube	Anillo de sujeción	1
6	NC / NS	Cloche	Cover	Haube	Campana	1
7	146 199 902	Ressort (x 10)	Spring (x 10)	Feder (10 St.)	Muelle (x 10)	1
9a	NC / NS	Bloc inverseur (voir Doc. 573.087.040)	Reversing block (refer to Doc. 573.087.040)	Umsteuerblock (siehe Dok. 573.087.040)	Bloque inversor (consultar Doc. 573.087.040)	1
*9b	144 630 720	Bloc inverseur droit avec deux roulements (voir Doc. 573.087.040)	Right reversing-block with two bearings (refer to Doc. 573.087.040)	Rechter Umsteuerblock mit zwei Lagerbuchsen (siehe Dok. 573.087.040)	Bloque inversor derecho con dos rodamientos (consultar Doc. 573.087.040)	1
22	933 151 277	Vis CHc M 6 x 20	Screw, model CHc M 6 x20	Schraube, M 6x20	Tornillo, tipo CHc M 6 x 20	2
24	046 250 011	Pont de fixation	Bracket	Befestigungsbügel	Puente de fijación	1
25	NC / NS	Vis HM 12 x 30	Screw, model HM 12 x 30	Schraube, HM 12 X 30	Tornillo, tipo HM 12 x 30	2
27	044 570 131	Chape femelle	Linkage, female	Federhalterung, weiblich	Chapa hembra	1
28	88 044	Vis HM 8 x 30	Screw, model HM 8 x 30	Schraube, HM 8 x 30	Tornillo, tipo HM 8 x 30	2
29	046 250 008	Embase inverseur	Base, reversing-block	Grundplatte, Umsteuerblock	Base inversor	1
30	905 120 902	Coude M 1/8 BSP - T 4x6	Elbow, model M 1/8 BSP - T 4x6	Winkel-Steckanschluss, AG 1/8 BSP - T 4x6	Codo, tipo M 1/8 BSP - T 4x6	5
31	046 250 015	Silencieux	Muffler	Schalldämpfer	Silenciador	4
32	NC / NS	Fond supérieur	Upper support	Oberer Zylinderflansch	Fondo superior	1
33	046 144 907	Ecrou piston	Nut, piston	Kolbenmutter	Tuerca pistón	1
34	046 258 010	Piston avec bague	Piston with ring	Kolben mit Buchse	Pistón con anillo	1
35	046 258 002	Cylindre	Cylinder	Zylinder	Cilindro	1
37	046 280 106	Bague de frottement (x 2)	Seal ring (x 2)	Dichtring (2 St.)	Anillo de deslizamiento (x 2)	2
38	909 420 114	Joint torique	O-Ring	O Ring	Junta tórica	2
39	NC / NS	Fond inférieur avec bague de guidage	Lower support with bushing guide	Unterer Zylinderflansch mit Führungsbuchse	Fondo inferior con anillo de dirección	1
40	NC / NS	Tige d'accouplement	Coupling rod	Kupplungsstange	Eje de acoplamiento	1
41	953 010 021	Ecrou HM 10	Nut, model HM 10	Mutter, HM 10	Tuerca, tipo HM 10	16
42	963 040 021	Rondelle MN 10	Washer, model MN 10	Scheibe, MN 10	Arandela, tipo MN 10	8
43	046 258 007	Tige de pilotage	Rod driving	Steuerstange	Eje de pilotaje	1
44	NC / NS	Joint de cylindre	Seal, cylinder	Zylinderdichtung	Junta de cilindro	2
45	909 130 521	Bague R 19	Ring, model R 19	O Ring, R 19	Junta, tipo R 19	2
46	909 420 225	Joint	Seal	Dichtung	Junta	2
48	144 579 923	Bague R 8 bis (x 10)	Ring, model R 8 bis (x 10)	O Ring, R 8 bis (10 St.)	Junta, tipo R 8 bis (x 10)	1
49	046 258 006	Bague de guidage (fond supérieur)	Bushing guide (upper support)	Führungsbuchse (oberer Zylinderflansch)	Anillo de dirección (fondo superior)	1

Ind	#	Désignation	Description	Bezeichnung	Denominación	Qté
50	NC / NS	Tirant moteur	Rod, air motor	Stehbolzen	Tirante motor	8
51	NC / NS	Bague R 81	Ring, model R 81	O Ring, R 81	Junta, tipo R 81	1
52	NC / NS	Tube de liaison	Rod, connecting	Verbindungsrohr	Tubo de unión	1
53	903 130 508	Raccord régulateur de pression	Fitting, pressure regulator	Druckreduzierventil	Racor regulador de presión	1
55	905 120 905	Raccord coudé M 1/4 BSP - T 4x6	Elbow, model M 1/4 BSP - hose 4x6	Winkel-Steckanschluss, AG 1/4 BSP - T 4x6	Codo, tipo M 1/4 BSP - T 4x6	1
57	NC / NS	Bride	Flange	Flansch	Brida	2
58	933 151 497	Vis CHc M 6 x 40	Screw, model CHc M 6 x 40	Schraube, M 6 x 40	Tornillo, tipo CHc M 6 x 40	4
59	NC / NS	Coude GF 1 - MF 3/4"	Elbow, model GF 1 - MF 3/4"	Winkelnippel GF 1 - AG/IG 3/4"	Codo, tipo GH 1 - MH 3/4"	4
-	NC / NS	Manchon	Nipple	Muffe	Manguito	4
60	044 570 900	Fourchette de commande assemblée	Fork assembly control	Umsteuerstange	Horquilla de mando equipada	1
-	901 180 024	Câble de mise à la terre (Lg. 5m)	Cable ground (5m / 196.85" length)	Erdungskabel (5 m)	Cable de puesta a tierra (5m de largo)	1
-	NC / NS	Traversée de cloison	Air connection	Schottverschraubung	Pasa muros	1
-	NC / NS	Tuyau 4x6	Hose 4x6 / 5/32" x 1/4"	Schlauch 4 x 6	Tubería 4x6	1m
-	905 120 903	Té	Tee	T-Stück	Te	1
-	NC / NS	Bouchon	Plug	Blindstopfen	Tapón	1
-	NC / NS	Vis HM 4x20	Screw, model HM 4x20	Schraube, HM 4x20	Tornillo, tipo HM 4x20	4
-	NC / NS	Rondelle AZ 6	Washer, model AZ 6	Scheibe, AZ 6	Arandela, tipo AZ 6	1
-	934 011 196	Vis HM 6x16	Screw, model HM 6x16	Schraube, HM 6x16	Tornillo, tipo HM 6x16	1

Ind	#	Désignation	Description	Bezeichnung	Denominación	Qté
*	146 258 991	Pochette de joints moteur (ind. 7, 37(x2), 38(x2), 44(x2), 45(x2), 46(x2), 48, 51 + pochette de joints inverseur)	Seal kit (air motor) (ind. 7, 37(x2), 38(x2), 44(x2), 45(x2), 46(x2), 48, 51 + seal kit (reversing-block))	Dichtungssatz für Luftmotor Pos. 7, 37(x2), 38(x2), 44(x2), 45(x2), 46(x2), 48, 51 + Dichtungssatz für Umsteuerblock)	Bolsa de juntas motor (ind. 7, 37(x2), 38(x2), 44(x2), 45(x2), 46(x2), 48, 51 + bolsa de juntas del bloque inversor)	1
*	146 258 996	Pochette de maintenance (Pochette # 146.258.991 + ind. 2, 4, 7, 8, 13 de l'inverseur)	Servicing kit (Seal kit # 146.258.991 + ind. 2, 4, 7, 8, 13 of the reversing-block)	Reparatursatz (Dichtungssatz Nr. 146.258.991 + Pos. 2, 4, 7, 8, 13 für Umsteuerblock)	Bolsa de reparación (Bolsa # 146.258.991 + ind. 2, 4, 7, 8, 13 del bloque inversor)	1

* Pièces de maintenance préconisées.

* Preceding the index number denotes a suggested spare part.

* Bezeichnete Teile sind empfohlene Ersatzteile.

* Piezas de mantenimiento preventivas.

N C : Non commercialisé.

N S : Denotes parts are not serviceable.

N S : Bezeichnete Teile gibt es nicht einzeln, sondern nur komplett .

N S : no suministrado.

Nota : Les pompes dont le numéro de série est > à 17 K 1146 sont équipées du bloc inverseur # 144.630.720. Ne monter l'ind. 2 (bague de guidage du bloc inverseur) que si votre bloc comporte un R.

Nota : The pumps with serial number is > to 17 K 1146 are fitted with the reversing-block # 144.630.720. Install ind. 2 (guide ring of the reversing-block) only if your reversing-block has R.

Hinweis: Die Pumpen mit der Fertigungsnummer > bis 17 K 1146 sind mit dem Umsteuerblock # 144.630.720 bestückt. Die Pos. 2 (Führungsbuchse des Umsteuerblocks) nur am Umsteuerblock mit R Markierung montieren.

Nota : Las bombas cuyo número de serie es > a 17 K 1146 tienen el bloque inversor # 144.630.720. Montar el ind. 2 (anillo guía del bloque inversor) sólo si su bloque tiene un R.

<p>Doc. 573.087.040 Date/Datum/Fecha : 11/05/17 Annule/Cancel/ Ersetzt/Anula : 03/06/14</p>	<p>Modif. / Änderung : Mise à jour / Update / Aktualisierung / Actualización + 144.630.720</p>	<p>Pièces de rechange Spare parts list Ersatzteilliste Piezas de repuesto</p>
---	--	--

BLOC INVERSEUR	REVERSING-BLOCK	#
UMSTUERBLOCK	BLOQUE INVERSOR	NC / NS

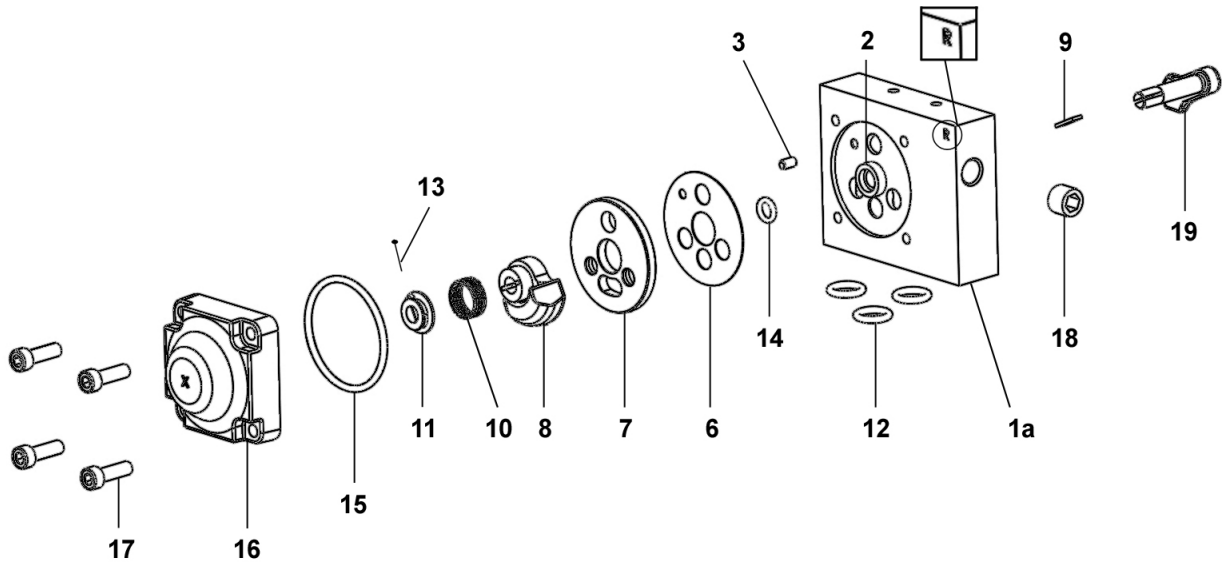

BLOC INVERSEUR DROIT AVEC DEUX ROULEMENTS	RIGHT REVERSING-BLOCK WITH TWO BEARINGS	#
RECHTER UMSTUERBLOCK MIT ZWEI LAGERBUCHSEN	BLOQUE INVERSOR DERECHO CON DOS RODAMIENTOS	144.630.720

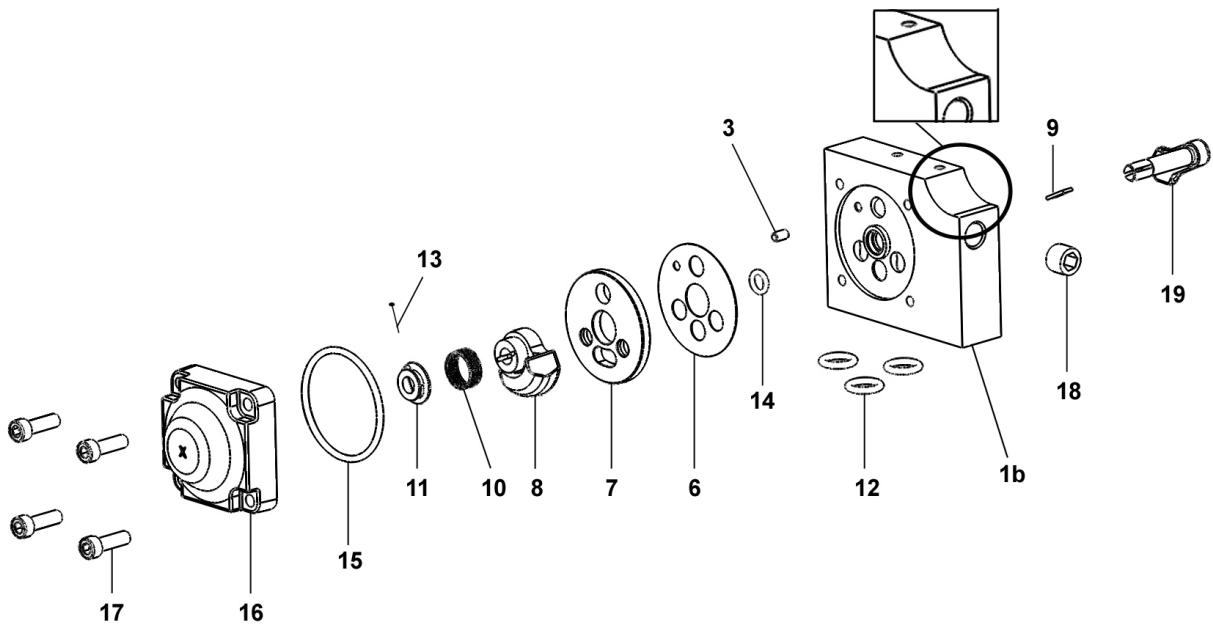

BLOC INVERSEUR	REVERSING-BLOCK	#
UMSTEUERBLOCK	BLOQUE INVERSOR	NC / NS

BLOC INVERSEUR DROIT AVEC DEUX ROULEMENTS	RIGHT REVERSING-BLOCK WITH TWO BEARINGS	#
RECHTER UMSTEUERBLOCK MIT ZWEI LAGERBUCHSEN	BLOQUE INVERSOR DERECHO CON DOS RODAMIENTOS	144.630.720

Pièces communes - Common parts - Gleiche Teile - Partes comunes

Ind	#	Désignation	Description	Bezeichnung	Denominación	Qté
*6	144 579 912	Joint de glace fixe (x 10)	Gasket seal (x 10)	Flachdichtung (10 x)	Junta de espejo fijo (x 10)	1
*7	046 170 508	Glace fixe	Base, fixed	Ventilplatte	Espejo fijo	1
*8	044 570 324	Glace mobile	Base, mobile	Ventilschieber	Espejo móvil	1
9	044 570 325	Clavette	Pin	Paßfeder (Keil)	Pasador	1
10	921 140 102	Ressort	Spring	Feder	Muelle	1
11	044 571 006	Butée de ressort	Stop, spring	Federführung	Tope de muelle	1
*12	144 579 922	Bague R 10 (x 10)	Ring, model R 10 (x 10)	O Ring R 10 (x 10)	Anillo, tipo R 10 (x 10)	3
*13	144 579 911	Goupille fendue (pochette de 10 goupilles + 1 butée ind. 11)	Pin (package of 10 pins + 1 stop ind. 11)	Splint (Satz à 10 Stück + 1 Führung Pos. 11)	Pasador (bolsa de 10 pasadores + 1 tope ind. 11)	1
*14	144 579 910	Bague R 6a (x 10)	Ring, model R 6a (x 10)	O Ring, R 6a (10 x)	Anillo, tipo R 6a (x 10)	1
*15	NC / NS	Joint de couvercle	Seal, cover	Deckeldichtung	Junta de tapa	1
16	144 630 415	Couvercle	Cover	Deckel	Tapa	1
17	933 151 277	Vis CHc M 6x20	Screw, model CHc M 6x20	Schraube, CHc M 6x20	Tornillo, tipo CHc M 6x20	4
18	906 333 102	Bouchon 1/4 BSP	Plug, model 1/4 BSP	Blindstopfen, 1/4 BSP	Tapón, tipo 1/4 BSP	1
19	046 170 510	Levier	Lever, control	Umsteuerhebel	Leva	1

Ind	#	Désignation	Description	Bezeichnung	Denominación	Qté
*	146 270 950	Pochette de joints (ind. 6, 12(x3), 14, 15)	Package of seals (ind. 6, 12(x3), 14, 15)	Dichtungssatz (bestehend aus Pos. 6, 12(x3), 14, 15)	Bolsa de juntas (ind. 6, 12(x3), 14, 15)	1
*	144 630 425	Pochette de maintenance glaces (ind. 7, 8)	Servicing kit - bases (ind. 7, 8)	Servicekit - Ventil (Pos. 7, 8)	Bolsa de mantenimiento - espejos (ind. 7, 8)	1

Pièces spécifiques - Specific parts - Spezifische Teile - Partes específicas

Pour / for / für / para # NC / NS

Ind	#	Désignation	Description	Bezeichnung	Denominación	Qté
*	144 630 410	Corps équipé	Block assembly, reversing	Umsteuerblock komplett	Cuerpo equipado	1
1a	NC / NS	▪ Corps	▪ Body	▪ Körper	▪ Cuerpo	1
2	NC / NS	▪ Bague de guidage	▪ Guide ring	▪ Führungsbuchse	▪ Anillo guía	1
3	NC / NS	▪ Goupille Ø 4 x 8	▪ Pin Ø 4 x 8	▪ Splint Ø4 x 8	▪ Pasador Ø 4 x 8	1
-	NC / NS	▪ Butée (collée sur corps ind.1a)	▪ Stop (glued on part ind. 1a)	▪ Anschlag (auf Körper geklebt ind.1a)	▪ Tope (pegado en cuerpo ind. 1a)	2
-	NC / NS	▪ Roulement à bille	▪ Ball bearing	▪ Kugellager	▪ Rodamiento de bolas	1

Pour / for / für / para # 144.630.720

Ind	#	Désignation	Description	Bezeichnung	Denominación	Qté
*	144 630 715	Corps équipé	Block assembly, reversing	Umsteuerblock komplett	Cuerpo equipado	1
1b	NC / NS	▪ Corps	▪ Body	▪ Körper	▪ Cuerpo	1
3	NC / NS	▪ Goupille Ø 4 x 8	▪ Pin Ø 4 x 8	▪ Splint Ø4 x 8	▪ Pasador Ø 4 x 8	1
-	NC / NS	▪ Butée (collée sur corps ind.1b)	▪ Stop (glued on part ind. 1b)	▪ Anschlag (auf Körper geklebt ind.1b)	▪ Tope (pegado en cuerpo ind. 1b)	2
-	NC / NS	▪ Roulement à bille	▪ Ball bearing	▪ Kugellager	▪ Rodamiento de bolas	2

* Pièces de maintenance préconisées.

* Preceding the index number denotes a suggested spare part.

* Bezeichnete Teile sind empfohlene Ersatzteile.

* Piezas de mantenimiento preventivas.

NC : Non commercialisé.

NS : Denotes parts are not serviceable.

NS : Bezeichnete Teile gibt es nicht einzeln, sondern nur komplett .

NS : no suministrado.

Nota : Ne monter l'ind. 2 (bague de guidage du bloc inverseur) que si votre bloc inverseur comporte un R.

Nota : Install ind. 2 (guide ring of the reversing-block) only if your reversing-block has R.

Hinweis: Die Pos. 2 (Führungsbuchse des Umsteuerblocks) nur am Umsteuerblock mit R Markierung montieren.

Nota : Montar el ind. 2 (anillo guía del bloque inversor) sólo si su bloque inversor tiene un R.

Doc. 573.409.050 Date/Datum/Fecha : 09/02/21 Annule/Cancel/ Ersetzt/Anula : 26/11/18	Modif. / Änderung : + # 144 020 691, # 144 020 692	Pièces de rechange Spare parts list Ersatzteilliste Piezas de repuesto
--	--	---

HYDRAULIQUE FLOWMAX®, modèle F260	FLOWMAX® FLUID SECTION, model F260
FLOWMAX® HYDRAULIKTEIL, model F260	HIDRÁULICA FLOWMAX®, model F260

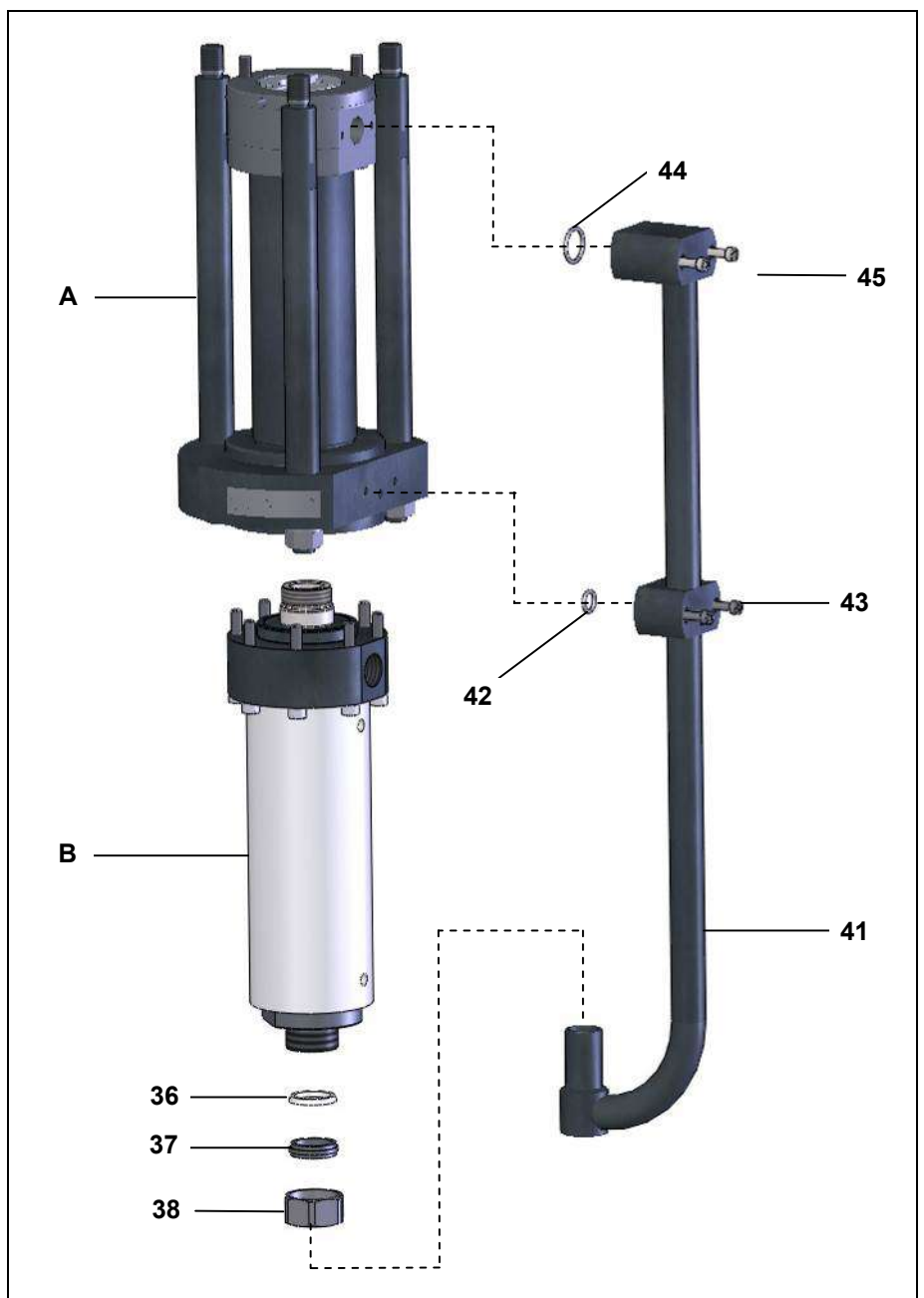
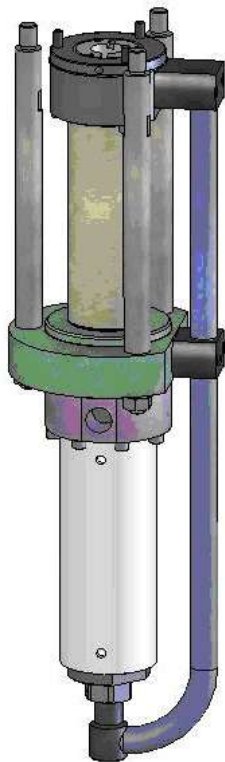

Ind. A

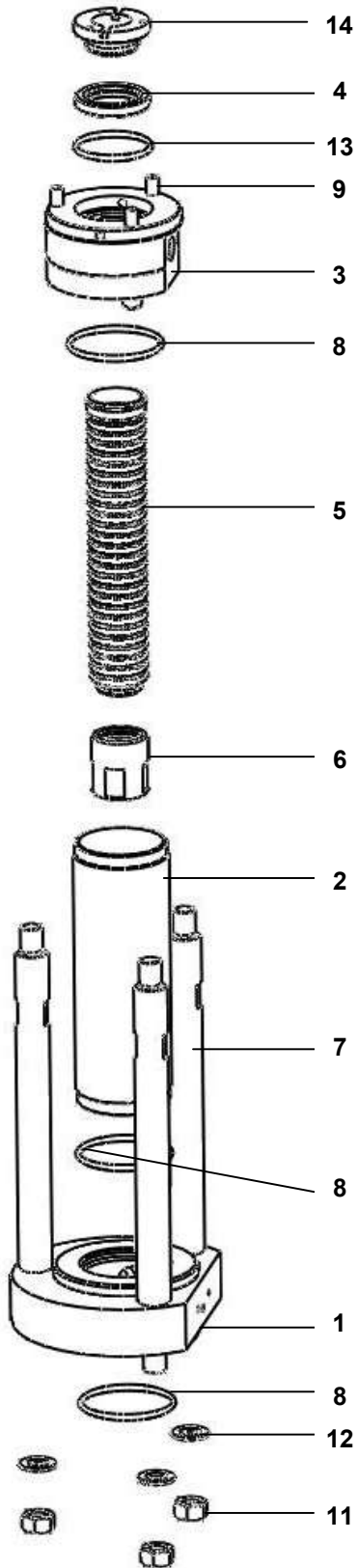

Ind. B

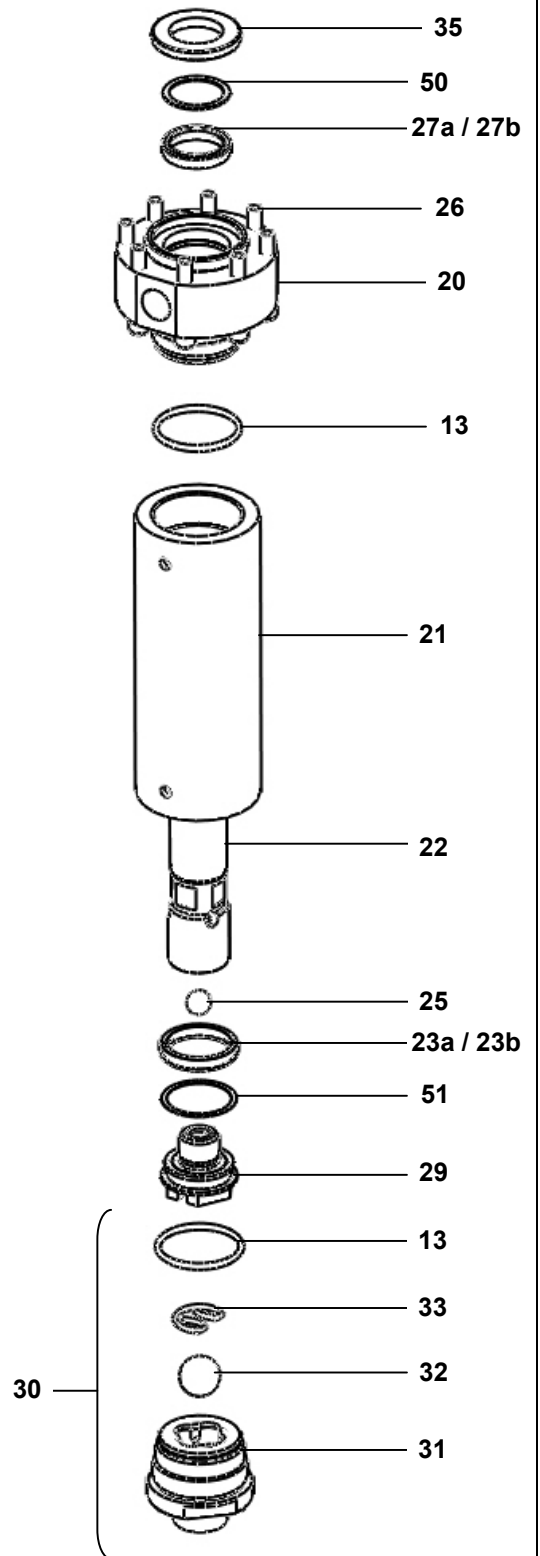

HYDRAULIQUE FLOWMAX®, modèle F260 AVEC CARTOUCHE GT	FLOWMAX® FLUID SECTION, model F260 WITH GT CARTRIDGE	#
FLOWMAX® HYDRAULIKTEIL, Modell F260 MIT GT PACKUNG	HIDRÁULICA FLOWMAX®, tipo F260 CON CARTUCHO GT	NC / NS

HYDRAULIQUE FLOWMAX®, modèle F260 AVEC CARTOUCHE PU	FLOWMAX® FLUID SECTION, model F260 WITH PU CARTRIDGE	#
FLOWMAX® HYDRAULIKTEIL, Modell F260 MIT PU PACKUNG	HIDRÁULICA FLOWMAX®, tipo F260 CON CARTUCHO PU	NC / NS

Pièces communes - Common parts - Gleiche Teile - Partes comunes

Ind	#	Désignation	Description	Bezeichnung	Denominación	Qté
1	044 990 011	Bride d'aspiration	Suction flange	Unterer Flansch	Brida de aspiración	1
2	044 990 012	Cylindre	Cylinder	Saugzylinder	Cilindro	1
3	044 990 311	Palier d'aspiration	Suction bearing	Oberer Flansch	Palier de aspiración	1
4	044 970 253	Bride soufflet inférieure	Bellows flange, lower	Faltenbalg-Flansch	Brida fuelle inferior	1
*5	044 970 055	Soufflet	Bellows	Faltenbalg	Fuelle	1
6	044 990 313	Jupe	Skirt	Klemmstück	Faldón	1
7	044 990 016	Tirant d'accouplement	Coupling rod	Kupplungsstange	Tirante de acoplamiento	3
*8	NC / NS	Joint PTFE	Seal, PTFE	Dichtung PTFE	Junta PTFE	3
9	933 151 671	Vis CHc M 8x75	Screw, model CHc M 8x75	Schraube M 8x75	Tornillo, tipo CHc M 8x75	3
11	953 010 025	Ecrou HM 16	Nut, model HM 16	Mutter M 16	Tuerca, tipo HM 16	3
12	963 020 025	Rondelle Z 16	Washer, model Z 16	Scheibe 16	Arandela, tipo Z 16	3
*13	NC / NS	Joint PTFE	Seal, PTFE	Dichtung aus PTFE	Junta PTFE	3
14	044 970 252	Bride soufflet supérieure	Bellows flange, upper	Oberer Faltenbalg- Flansch	Brida fuelle superior	1
20	044 020 001	Bride de refoulement	Discharge flange	Druckflansch	Brida de expulsión	1
*21	044 020 006	Cylindre	Cylinder	Materialzylinder	Cilindro	1
*22	044 020 602	Piston	Piston	Kolben	Pistón	1
25	907 414 242	Bille Ø 16, inox 440 C	Ball Ø 16, stainless steel, 440 C	Kugel Ø 16 Edelstahl 440C	Bola Ø 16, inox 440 C	1
26	933 151 601	Vis CHc M 8x60	Screw, model CHc M 8x60	Schraube M 8x60	Tornillo, tipo CHc M 8x60	8
*29	144 020 620	Clapet de refoulement	Exhaust valve	Druckventil	Válvula de expulsión	1

Ind	#	Désignation	Description	Bezeichnung	Denominación	Qté
30	144 020 200	Clapet d'aspiration	Suction valve assembly	Saugventil komplett	Válvula de aspiración	1
31	NC / NS	▪ Corps de clapet	▪ Suction valve body	▪ Saugventilkörper	▪ Cuerpo de válvula	1
32	907 414 269	▪ Bille Ø 27,7, inox 440C	▪ Ball Ø 27,7, stainless steel 440C	▪ Kugel Ø 27,7, Edelstahl	▪ Bola Ø 27,7, inox 440C	1
33	044 695 010	▪ Jonc	▪ Rush	▪ Sicherungsring	▪ Anillo de retención bola	1
13	NC / NS	▪ Joint PTFE	▪ Seal, PTFE	▪ Dichtung aus PTFE	▪ Junta PTFE	-
35	044 020 007	Bague supérieure	Ring, upper	Obere Scheibe	Anillo superior	1
*36	144 970 106	Joint (x 10)	Seal (x 10)	O-Ring (10x)	Junta (x 10)	1
37	044 970 107	Bague de serrage	Tightening ring	Klemmring	Anillo de apriete	1
38	049 595 306	Ecrou raccord M 38x150	Fitting nut, model M 38x150	Überwurfmutter M 38x1,5	Tuerca racor, tipo M 38x150	1
41	044 990 051	Tube de liaison	Fluid tube, attachment	Verbindungsrohr	Tubo de unión	1
*42	129 489 902	Joint PTFE (x 10)	Seal, PTFE (x 10)	Dichtung PTFE (10x)	Junta PTFE (x 10)	1
43	NC / NS	Vis CHc M 6x45	Screw, model CHc M 6x45	Schraube M 6x45	Tornillo, tipo CHc M 6x45	2
*44	150 040 321	Joint PTFE (x 10)	Seal, PTFE (x 10)	Dichtung PTFE (10x)	Junta PTFE (x 10)	1
45	930 151 598	Vis CHc M 6x60	Screw, model CHc M 6x60	Schraube M 6x60	Tornillo, tipo CHc M 6x60	2

Pièces spécifiques - Specific parts - Spezifische Teile - Partes específicas

Mod. F260 avec joints GT / with GT seals / mit GT Dichtung / con juntas GT

Ind	#	Désignation	Description	Bezeichnung	Denominación	Qté
23a	909 150 226	Joint GT inférieur	GT seal, lower	Untere GT- Dichtung	Junta GT inferior	1
27a	909 150 228	Joint GT supérieur	GT seal, upper	Obere GT-Dichtung	Junta GT superior	1

Mod. F260 avec joints PU / with PU seals / mit PU Dichtung / con juntas PU

Ind	#	Désignation	Description	Bezeichnung	Denominación	Qté
23b	909 060 303	Joint de piston (PU)	Piston seal (Polyurethane)	Kolbendichtung (PU)	Junta de pistón (Poliuretano)	1
27b	909 060 304	Joint de tige (PU)	Rod seal (Polyurethane)	Kolbendichtung (PU)	Junta de eje (Poliuretano)	1
50	044 990 046	Rondelle de calage	Adjustment block	Höenpassung	Cuña de ajuste	1
51	044 990 047	Rondelle de calage	Adjustment block	Höenpassung	Cuña de ajuste	1

**MONTAGE DES JOINTS - ASSEMBLY OF THE SEALS
MONTAGE DER DICHTUNGEN - MONTAJE DE LAS JUNTAS**

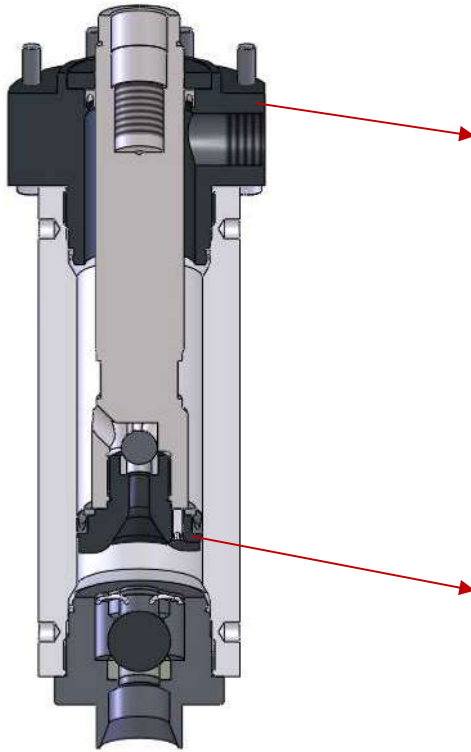

Mod. F260
avec joints GT / with GT seals / mit GT Dichtung
/ con juntas GT

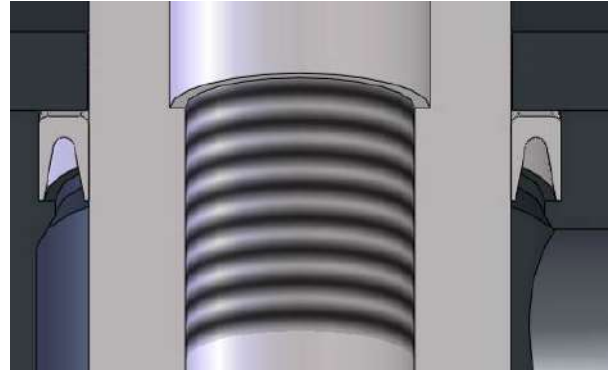

Ind. 27a

Ind. 23a

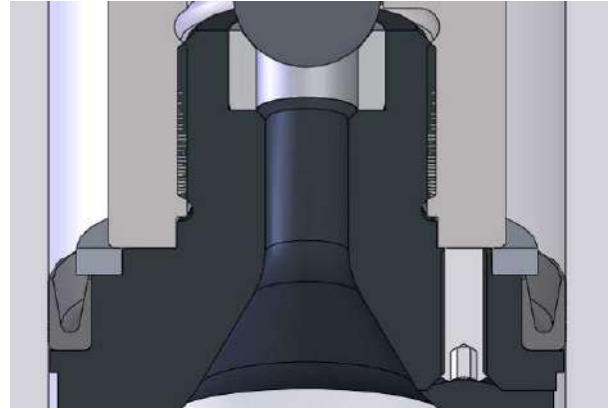

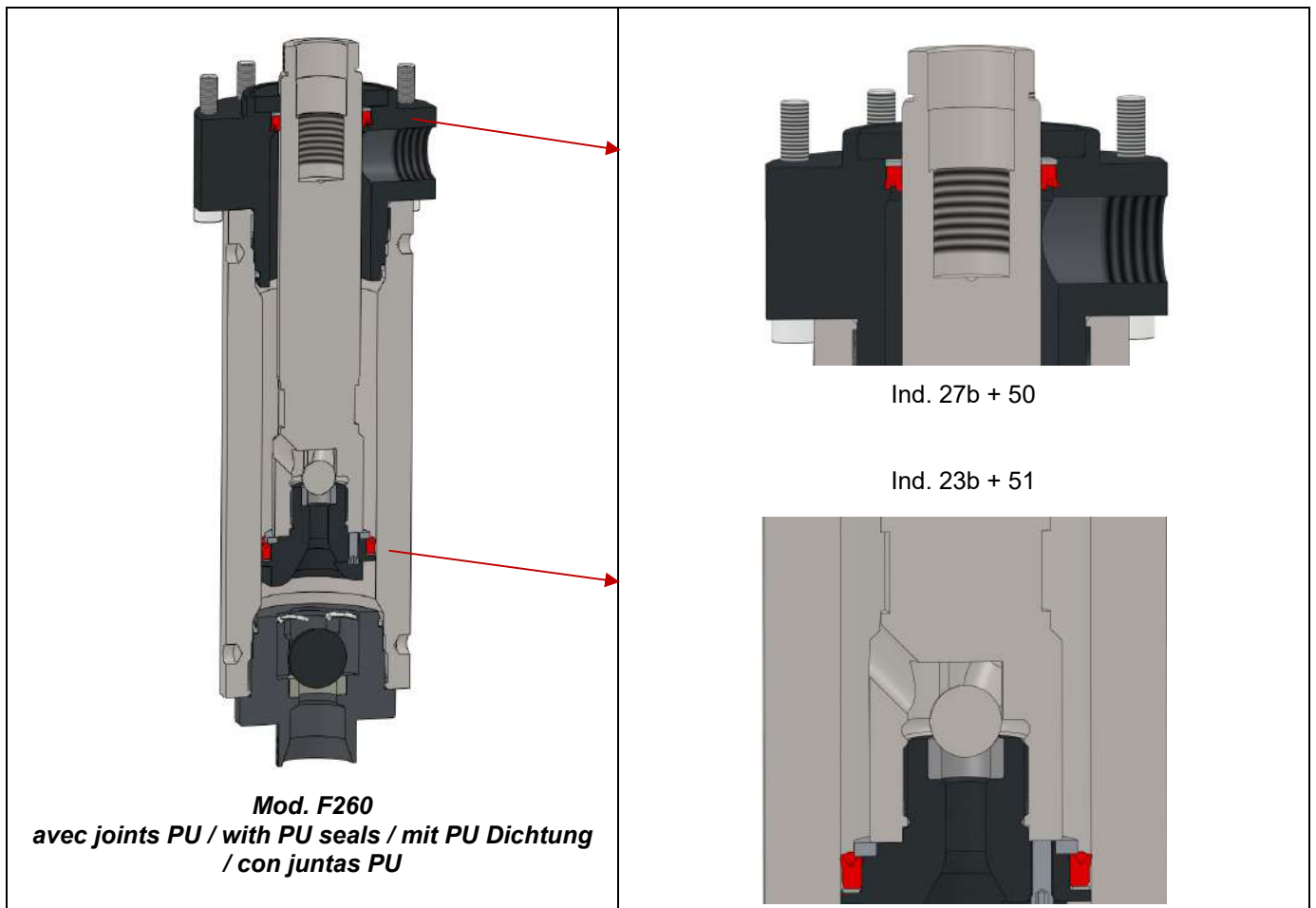

ACCESSOIRES - ACCESSORIES - ZUBEHÖR - ACCESORIOS



Ind	#	Désignation	Description	Bezeichnung	Denominación	Qté
53	051 881 459	Flamme : outillage pour montage garniture	Piston rod starter tool	Konus zur Montage der Packung	Herramienta para montar guarnición	1

Ind	#	Désignation	Description	Bezeichnung	Denominación	Qté
*	144 020 690	Pochette de joints (ind. 8 (x3), 13 (x3), 23, 25, 27, 32, 33, 36, 42, 44)	Seal kit (ind. 8 (x3), 13 (x3), 23, 25, 27, 32, 33, 36, 42, 44)	Dichtungssatz (Pos. 8 (3x), 13 (3x), 23, 25, 27, 32, 33, 36, 42, 44)	Bolsa de juntas (ind. 8 (x3), 13 (x3), 23, 25, 27, 32, 33, 36, 42, 44)	1
*	144 020 695	Pochette de maintenance (ind. 29 + 30 + pochette de joints # 144 020 690)	Servicing kit (ind. 29 + 30 + Seal kit # 144 020 690)	Reparatursatz (Pos. 29 + 30 + Dichtungssatz # 144 020 690)	Bolsa de mantenimiento (ind. 29 + 30 + bolsa de juntas # 144 020 690)	1
*	144 020 691	Pochette de joints - PU (ind. 8 (x3), 13 (x3), 23b, 25, 27b, 32, 33, 36, 42, 44, 50, 51)	Seal kit - PU (ind. 8 (x3), 13 (x3), 23b, 25, 27b, 32, 33, 36, 42, 44, 50, 51)	Dichtungssatz - PU (Pos. 8 (x3), 13 (x3), 23b, 25, 27b, 32, 33, 36, 42, 44, 50, 51)	Bolsa de juntas - PU (ind. 8 (x3), 13 (x3), 23b, 25, 27b, 32, 33, 36, 42, 44, 50, 51)	1
*	144 020 692	Pochette de maintenance - PU (ind. 29 + 30 + pochette de joints # 144 020 691)	Servicing kit - PU (ind. 29 + 30 + Seal kit # 144 020 691)	Reparatursatz - PU (Pos. 29 + 30 + Dichtungssatz # 144 020 691)	Bolsa de mantenimiento - PU (ind. 29 + 30 + bolsa de juntas # 144 020 691)	1

* Pièces de maintenance préconisées.

* Preceding the index number denotes a suggested spare part.

* Bezeichnete Teile sind empfohlene Ersatzteile.

* Piezas de mantenimiento preventivas.

N C : Non commercialisé.

N S : Denotes parts are not serviceable.

N S : Bezeichnete Teile gibt nicht einzeln, sondern nur komplett .

N S : no suministrado.

Doc. 573.327.050 Date/Datum/Fecha : 15/11/18 Annule/Cancel/ Ersetzt/Anula : 10/10/11	Modif. / Änderung : Mise à jour / Update / Aktualisierung / Actualización	Pièces de rechange Spare parts list Ersatzteilliste Piezas de repuesto
--	--	---

FILTRE PRODUIT HP, modèle 3/4 inox	HP FLUID FILTER, model 3/4 stainless steel
HP MATERIALFILTER, Modell 3/4 Edelstahl	FILTRO PRODUCTO AP, tipo 3/4 inox

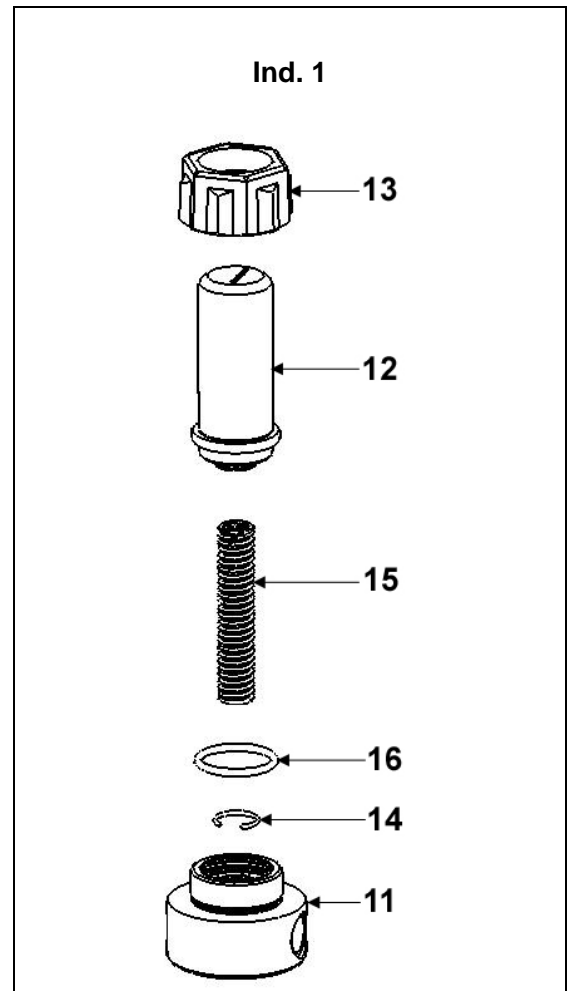
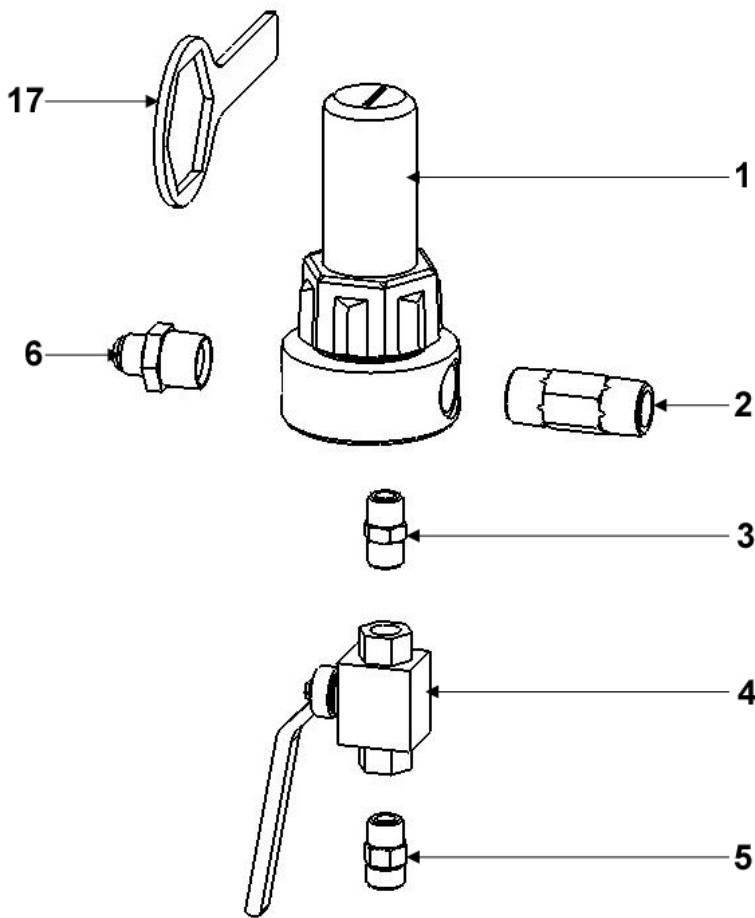

FILTRE EQUIPÉ pour pompes AIRLESS®	EQUIPPED FILTER for AIRLESS pumps	# 155.581.400
AUSGERÜSTETER FILTER für AIRLESS-Pumpen	FILTRO EQUIPADO para bombas AIRLESS	

Ind	#	Désignation	Description	Bezeichnung	Denominación	Qté
*1	155 581 450	Filtre nu inox (voir détail)	Bare filter, stainless steel (see detail)	Nackter Filter - Edelstahl (Siehe Detail)	Filtro solo, inox (consultar detalle)	1
2	055 581 401	Mamelon inox 3/4 NPS	Nippel 3/4 NPS, stainless steel	Rohnippel 3/4 NPS, Edelstahl	Pivote de centrado inox 3/4 NPS	1
3	905 240 002	Raccord inox MM 3/8 NPT	Fitting, double male, 3/8 NPT	Doppelnippel AG 3/8 NPT	Racor inox, MM 3/8 NPT	1
*4	903 090 220	Vanne HP FF 3/8 BSP	HP valve FF 3/8 BSP	Kugelhahn, IG 3/8 BSP	Válvula AP, HH 3/8 BSP	1
5	050 102 436	Raccord inox M 18 x 125 - M 3/8 BSP	Adaptor, stainless steel, double male 18x125 - 3/8BSP	Doppelnippel - Edelstahl AG 3/8 BSP - M 18x1,25	Racor inox, M 18 x 125 - M 3/8 BSP	1
6	905 210 515	Raccord inox M 3/4 NPT - M 3/4 JIC	Adaptor, stainless steel, double male, 3/4 NPT - # 8 JIC (3/4 JIC)	Doppelnippel Edelstahl 3/4 NPT - 3/4 JIC	Racor, inox M 3/4 NPT - M 3/4 JIC	1
*7	000 161 112	Tamis n° 12 (280 µ)	Screen n° 12 (280 µ - 55 Mesh)	Filterelement Sieb Nr. 12 (280 µ)	Tamiz n° 12 (280 µ)	1

FILTRE NU (sans tamis)	BARE FILTER (without screen)	# 155.581.450
NACKTER FILTER (ohne Sieb)	FILTRO SOLO (sin tamiz)	

Ind	#	Désignation	Description	Bezeichnung	Denominación	Qté
11	055 581 451	Embase 3/4	Base, model 3/4	Grundblock, Modell 3/4	Base, tipo 3/4	1
12	055 580 202	Cuve	Bowl	Filterglocke	Cubeta	1
13	055 280 002	Ecrou	Nut	Überwurfmutter	Tuerca	1
14	055 190 007	Jonc	Stop ring	Sicherungsring	Clips	1
15	055 190 005	Ressort	Spring	Feder	Muelle	1
*16	150 040 327	Joint (les 5)	Seal (pack of 5)	Dichtung (5 St.)	Junta (bolsa de 5)	1
17	049 030 018	Clé de démontage	Wrench	Schlüssel	Llave de desmontaje	1

* Pièces de maintenance préconisées.

* Preceding the index number denotes a suggested spare part.

* Bezeichnete Teile sind empfohlene Ersatzteile.

* Piezas de mantenimiento preventivas.

Ind. 7



Ind	#	Désignation	Description	Bezeichnung	Denominación	Qté
-	000 161 101	Tamis n° 1 (37 µ)	Screen n° 1 (37 µ)	Sieb Nr. 1 (37 µ)	Tamiz n° 1 (37µ)	1
-	000 161 102	Tamis n° 2 (77 µ)	Screen n° 2 (77 µ)	Sieb Nr. 2 (77 µ)	Tamiz n° 2 (77 µ)	1
-	000 161 104	Tamis n° 4 (99 µ)	Screen n° 4 (99 µ)	Sieb Nr. 4 (99 µ)	Tamiz n° 4 (99 µ)	1
-	000 161 106	Tamis n° 6 (168 µ)	Screen n° 6 (168 µ)	Sieb Nr. 6 (168 µ)	Tamiz n° 6 (168 µ)	1
-	000 161 108	Tamis n° 8 (210 µ)	Screen n° 8 (210 µ)	Sieb Nr. 8 (210 µ)	Tamiz n° 8 (210 µ)	1
7	000 161 112	Tamis n° 12 (280 µ)	Screen n° 12 (280 µ)	Sieb Nr. 12 (280 µ)	Tamiz n° 12 (280 µ)	1
-	000 161 115	Tamis n° 15 (360 µ)	Screen n° 15 (360 µ)	Sieb Nr. 15 (360 µ)	Tamiz n° 15 (360 µ)	1
-	000 161 020	Tamis n° 20 (510 µ)	Screen n° 20 (510 µ)	Sieb Nr. 20 (510 µ)	Tamiz n° 20 (510 µ)	1
-	000 161 030	Tamis n° 30 (750 µ)	Screen n° 30 (750 µ)	Sieb Nr. 30 (750 µ)	Tamiz n° 30 (750 µ)	1

OPTION - ON REQUEST - OPTIONEN - OPCIÓN

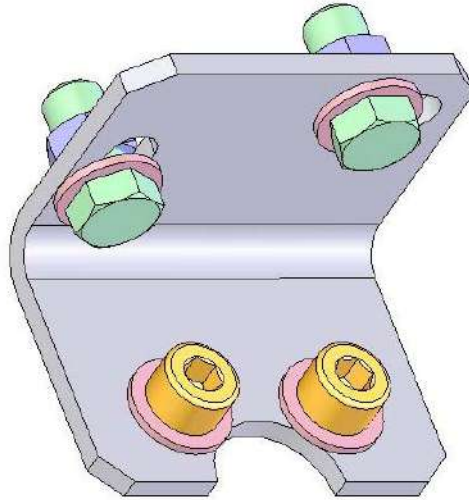

Ind	#	Désignation	Description	Bezeichnung	Denominación	Qté
-	155 190 105	Support filtre avec vis, rondelles et écrous	Mounting bracket with screws, washers and nuts	Filterhalterung mit Schrauben, Scheiben und Muttern	Soporte filtro con tornillos, arandelas y tuercas	1



AIRLESS PUMP

PREVENTIVE MAINTENANCE

TRANSLATION FROM THE ORIGINAL MANUAL

IMPORTANT : Before assembly and start-up, please read and clearly understand all the documents relating to this equipment (professional use only).

THE PICTURES AND DRAWINGS ARE NON CONTRACTUAL. WE RESERVE THE RIGHT TO MAKE CHANGES WITHOUT PRIOR NOTICE.

SAMES KREMLIN SAS
13, chemin de Malacher
38 240 - MEYLAN - France
☎ : 33 (0)4 76 41 60 60

www.sames-kremlin.com

▪ PUMP

Make sure that the pump is clean and in good condition to increase equipment working life.

If the pump is a intensive™ one :

- Make sure the pump fluid outlet flange is always filled up with T lubricant (this T lubricant will normally be coloured by the paint).

- Regularly clean the wetting-cup with solvent after having drained the lubricant (Unscrew the plug placed at the upper flange).

Guards (motor cover, coupling shields, connectors,...) have been designed for a safe use of the equipment.

The manufacturer will not be held responsible for bodily injury or failure and / or property damage due to destruction, the overshadowing or the partial or total removal of the guards.

Make sure that the suction strainer is clean and in good condition. Clean it regularly and replace it if it is necessary.

Flush the pump as often as necessary, specially when spraying pigment filled-material.

Whatever the case, when stopping the pump, always leave it filled with material :
For a short duration shutdown, if the flushing has not been carried out, leave the pump filled with material.
For a long duration shutdown, after flushing, leave it filled with solvent.

▪ SPRAY GUN

Comply with the usual instructions of spray gun servicing (refer to spray gun manual).

▪ FILTER

If the pump is equipped with a filter at the fluid outlet, comply with the usual instructions of filter servicing (refer to filter manual).



HIGH PRESSURE PUMP FOR AIRMIX® AND AIRLESS SPRAYING TROUBLESHOOTING

TRANSLATION FROM THE ORIGINAL MANUAL

IMPORTANT : Before assembly and start-up, please read and clearly understand all the documents relating to this equipment (professional use only).

THE PICTURES AND DRAWINGS ARE NON CONTRACTUAL. WE RESERVE THE RIGHT TO MAKE CHANGES WITHOUT PRIOR NOTICE.

SAMES KREMLIN SAS
13, chemin de Malacher
38 240 - MEYLAN - France
☎ : 33 (0)4 76 41 60 60

www.sames-kremlin.com

CAUSE	SOLUTION
The pump does not start.	Check the pump air supply.
Priming trouble : → Air is always coming out from the spray gun. → Air (or material) does not come out from the spray gun.	Be sure that the spray gun is fully opened and air evacuated through this one. Air intake at the fitting or at the suction rod. Check the pump valves. If a valve is stucked by dry paint, it can be unsticked without disassembling it. Blow air pressure directly by suction fitting.
The pump does not stop at once when shutting off the spray gun : → The pump stops only on down stroke. → The pump stops only on up stroke.	Check exhaust valve or valve seal. Check suction valve or upper cartridge.
The pump does not reverse.	Check spring of the air motor reversing-block. Lubricate reversing-block with HP 150 oil. Check if there is pilot air (depending on air motor model).
On intensive™ pump, the lubricant into the cup is fastly coloured.	Check the upper packing (tighten the cup or change seals if it is necessary).
On FLOWMAX® pump, leakage of fluid at the bottom of the air motor.	Check bellow.
Spraying trouble.	Refer to spray gun manual.
Decrease of material flow.	Refer to filter instruction manual.



**HIGH PRESSURE PUMP
FOR AIRMIX® AND AIRLESS SPRAYING**

***OPERATING PRINCIPLE
AND START-UP***

TRANSLATION FROM THE ORIGINAL MANUAL

IMPORTANT : Before assembly and start-up, please read and clearly understand all the documents relating to this equipment (professional use only).

THE PICTURES AND DRAWINGS ARE NON CONTRACTUAL. WE RESERVE THE RIGHT TO MAKE CHANGES WITHOUT PRIOR NOTICE.

SAMES KREMLIN SAS
13, chemin de Malacher
38 240 - MEYLAN - France
☎ : 33 (0)4 76 41 60 60

www.sames-kremlin.com

1. OPERATING PRINCIPLE

The pump (A) consists of :

- an alternating air motor (B).
- an hydraulic section(C) mechanically coupled to the air motor (B).

The air motor is supplied with compressed air by means of the regulator knob (D) (pantone 382 colour knob). The pressure is read on the gauge (E).

During its alternating movement, the air motor drives the piston of the hydraulic section (C). The fluid is drawn in (L) and forced under pressure in (N). Due to its design, the pressure is always the one read on the gauge (E) x the pump ratio.

⇒ To adjust the fluid flow rate, turn the regulator knob (D) (pantone 382 colour knob) (Gauge E).

The pumps are intensive™ ones or FLOWMAX ® ones (with bellow).

2. START UP

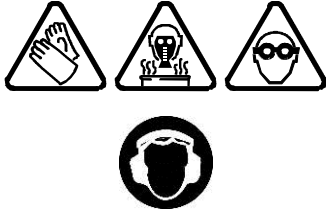

Protective clothing (gloves, protective masks, glasses, hearing protective earplug, protective clothing) should be worn to comply with the recommendations.

The working area must be correctly ventilated.

2-1 PUMP SUPPLIED IN SUCTION

STANDARD INTENSIVE™
PUMP

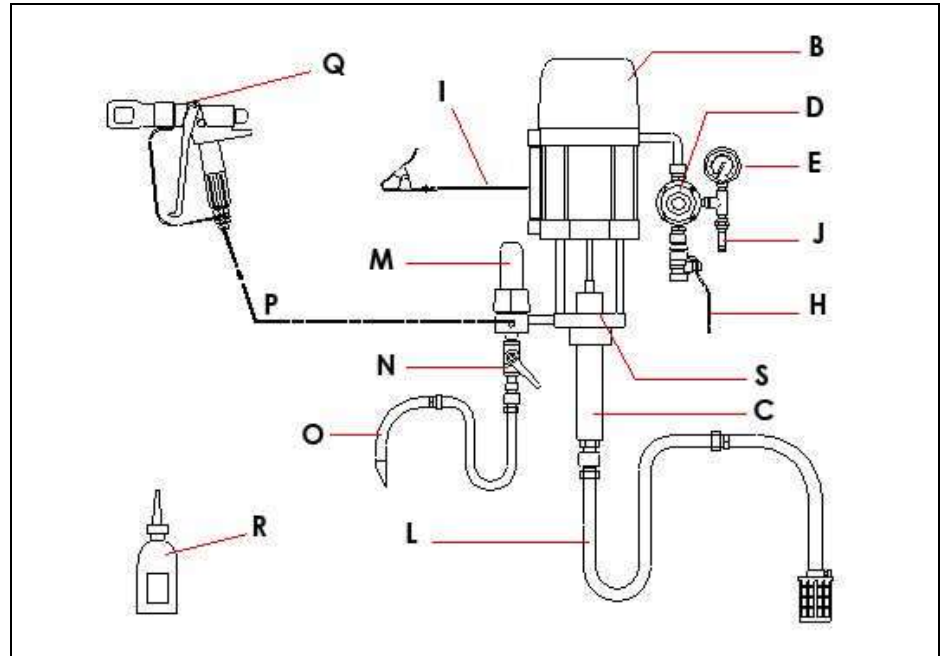

FLOWMAX® AIRLESS
PUMP

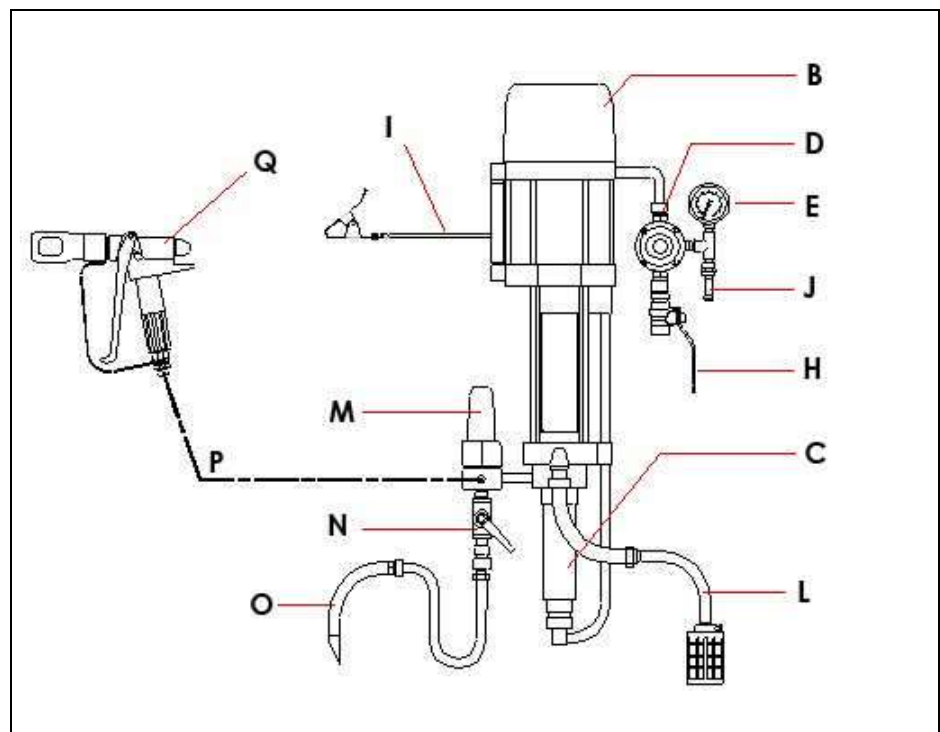

Captions :

A	Intensive™ or FLOWMAX ® pump (B + C)	L	Suction rod (depending on version)
B	Air motor	M	Accumulator filter (depending on version)
C	Fluid section	N	Air shut off valve (depending on version)
D	'MOTOR AIR' air regulator	O	Air shut off rod (depending on version)
E	Gauge	P	HP Fluid hose
H	Air inlet valve	Q	Gun
I	Ground	R	T lubricant (125 ml / 4.4 oz) (only for intensive™ pump)
J	Relief valve	S	Wetting-cup (only for intensive™ pump)

(For specific installation, please contact your SAMES KREMLIN representative).

Nota : If the pump is equipped with an accumulator filter (M), the filter is supplied with a screen n° 12 (filtration size : 280 µ or 55 mesh). The screen is recommended for the use of an AIRLESS gun fitted with a nozzle model 20. If the fluid spraying is carried out by means of an other nozzle, please choose an other screen (refer to filter instruction manual). Adjust the screen to the application.

Guards (air motor cover, coupling shields, housings ...) have been designed for safe use of the equipment.

The manufacturer will not be held responsible for bodily injury or failure and / or damage to property due to removal or partial removal of the guards

Start up procedure :

- 1 - Ground the pump.
- 2 - **If the pump is a intensive™ one, fill up the wetting-cup (S) with "T" lubricant (R) or with an appropriate solvent.**
- 3 - Unscrew the air regulator (D).
- 4 - Interconnect the equipment with the air pressure network (clean air - P < 6 bar / 87 psi). Install a water drop, model 3/4" if it is necessary.
- 5 - Connect all the hoses , compressed air general supply hose and fluid hose (P), as well as the gun (Q).
Nota : Comply with the diameters of hoses recommended in the specifications of the pump.
- 6 - Remove the nozzle from the gun.

■ **FLUSHING WITH SOLVENT**

- 7 - Immerse suction rod (L) and air shut off rod (O) into the material container.
- 8 - Open air shut off valve (N).
- 9 - Open the valve (H) of the pump air equipment to supply the air motor.
Nota : If the air motor is a 5000 or a 8000 version, it needs pilot air to operate. The pump air equipment supplies pilot air to the air motor. The air supply pressure is adjusted previously in the factory to 4 bar / 58 psi maximum.
- 10 - Increase the air regulator (D) so that the pump runs slowly (Pressure between 0.5 and 1 bar / 7.25 to 14.503 psi).
- 11 - Observe the drain (O); air bubbles come out from it. When bubbles no longer come out from it, shut off the drain valve (N).

▪ **PRIMING WITH MATERIAL**

- 12 - Remove suction rod (L) and drain rod (O) from material container and immerse them in a solvent filled container.
- 13 - Open drain valve (N), wait until the material flows out regularly, then shut off the drain valve (N).
- 14 - Point the spray gun towards the material container and trigger the gun until the material flows out regularly.

▪ **WORK**

- 12 - Remove suction rod (L) and drain rod (O) from material container and immerse them in a solvent filled container.
- 13 - Open drain valve (N), wait until the material flows out regularly, then shut off the drain valve (N).
- 14 - Point the spray gun towards the material container and trigger the gun until the material flows out regularly.

Nota : Some of these pumps are designed for AIRMIX ® spraying when using long hoses and medium or high viscosity fluids.

For this use, a spraying air kit shall be mounted on the pump air supply in order to feed compressed air to the spray gun.

2-2 PUMP SUPPLIED IN FILLING (CIRCULATING)

Interconnect the fluid inlet of the pump with the circulating supply hose and start up the pump as it is specified previously.

If the pump is a FLOWMAX ® one :

WARNING:

- **Fluid section filling pressure :** 2 bar maximum / 29 psi maximum
- **WARNING : Do not create overpressure.**
- **Never use** the pump when **an isolating gate on the supply circuit** (upstream from the FLOWMAX ® fluid section) is shut : **it would damage the bellows.**
- **Do not install** a material regulator on the supply circuit or any arrangement that could perform as **a non-return valve.**

3. SHUTDOWN AT THE END OF THE WORK

▪ SHORT DURATION SHUTDOWN

- 1 - Decrease the material pressure of air regulator (D) until reading **0 bar / 0 psi** on gauge (E).
- 2 - Trigger the gun to depressurize the system.
- 3 - Remove the nozzle of the spray gun and soak it into solvent.

▪ LONG DURATION SHUTDOWN

- 1 - Decrease the material pressure of air regulator (D) until reading **1 bar / 14.503 psi** on gauge (E).
- 2 - Remove the nozzle from the spray gun and soak it into solvent.
- 3 - Open the drain valve. The pump must operate at low speed. If the speed is too high, decrease the pump air pressure (D).
- 4 - Remove the suction rod and the drain rod from the material container and immerse it in a solvent-filled container. Take all the appropriate precautions in the presence of flammable solvents.
- 5 - When the solvent flows out clear and clean, close the drain valve.
- 6 - Point the spray gun towards the material container and press the gun trigger. When the solvent flows out, point the gun towards the recovery container.
- 7 - When the solvent flows out regularly, release the spray gun trigger.
Nota : If the pump is a intensive™ one, release the spray gun trigger when the pump piston is in a low position. To prevent from damaging the seals when starting once again the pump, the piston must be immersed into solvent.
- 8 - Fully unscrew the air regulator (D) and shut off the main compressed air valve (valve H).
- 9 - Trigger the spray gun trigger to decompress the hoses. Therefore, the pump and the hose remain filled with solvent at the atmospheric pressure.

4. SAFETY DEVICE

Guards (air motor cover, coupling shields, housings ...) have been designed for safe use of the equipment.

The manufacturer will not be held responsible for bodily injury or failure and / or damage to property due to removal or partial removal of the guards

A relief-valve (setting : 6.5 bar / 94 psi) is fitted on the pump air motor - thus protecting this one from an overpressure which could damage it.



FLOWMAX® AIRLESS PUMPS

40F260

65F260

TECHNICAL FEATURES

TRANSLATION FROM THE ORIGINAL MANUAL

IMPORTANT : Before assembly and start-up, please read and clearly understand all the documents relating to this equipment (professional use only).

THE PICTURES AND DRAWINGS ARE NON CONTRACTUAL. WE RESERVE THE RIGHT TO MAKE CHANGES WITHOUT PRIOR NOTICE.

SAMES KREMLIN SAS

13, chemin de Malacher
38 240 - MEYLAN - France

☎ : 33 (0)4 76 41 60 60

www.sames-kremlin.com

1. DESCRIPTION

- Air operated piston pump with a bellows seal fluid packing
- Low maintenance and ease of use. Use without lubrication

Designed for :

- Supplying one or several guns, model AIRLESS
- Spraying semi-fluids materials (anticorrosion material, glue)
- Circulating

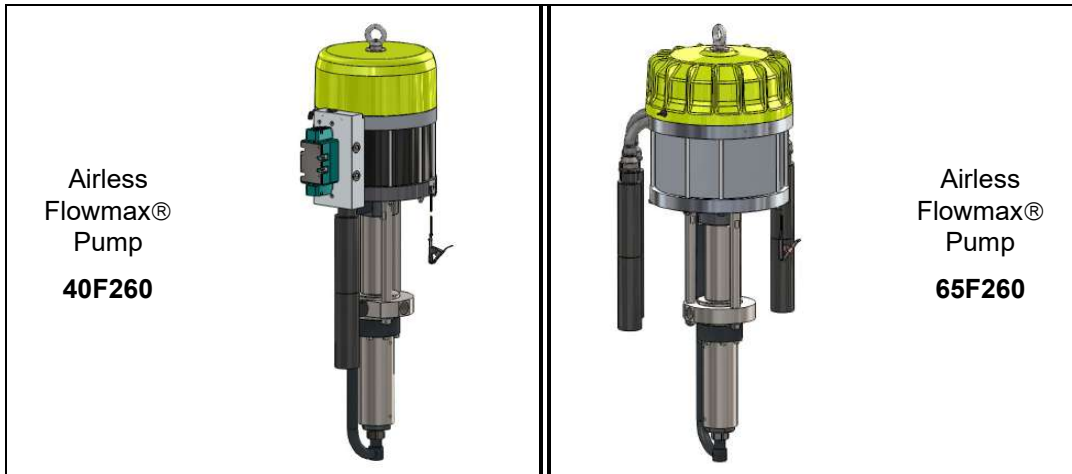

2. TECHNICAL FEATURES

▪ **FEATURES - PUMP, MODEL 40F260**

Motor model5000-4_2
 Body pump modelF260
 Theoretical pressure ratio40/1

Wetted parts :

Hard chrome stainless steel
 Stainless steel, Carbide

Tightness packings :

Bellows : polyethylene
 Upper fixed : GT seal (polyethylene) or PU
 Lower, mobile : GT seal (polyethylene) or PU

Air motor stroke	100 mm	4"
Air motor section	490 cm ²	75.95 sq.in
Fluid section	12 cm ²	1.9 sq.in
Delivery per cycle	240 cm ³	8.5 oz
Number of cycle per liter of material	4	15 per US gal
Flow (20 cycles)	4,8 l	1.27 US gal
Air pressure operating pressure	6 bar	88 psi
Maximum discharge pressure	240 bar	3480 psi
Weighted sound pressure (LAeq)	81.7 dBa*	81.7 dBa*
Maximum operating temperature	50° C	122° F

Weight : Wall mounted pump with suction rod110 kg / 242 lb
 Cart mounted pump140 kg / 309 lb

*** Test conditions - Noise level :**

- Test duration : 30 s,
- Motor air pressure : 6 bar,
- Material used : water,
- Flow rate : Pump adjusted at 20 cycles/minute

▪ **FEATURES - PUMP, MODEL 65F260**

Motor model8000-4_2	Air motor stroke	100 mm	4"
Body pump modelF260	Air motor section	804 cm ²	125 sq.in
Theoretical pressure ratio65/1	Fluid section	12 cm ²	1.9 sq.in
Wetted parts :	Delivery per cycle	240 cm ³	8.5 oz
Hard chrome stainless steel, Stainless steel, Carbide	Number of cycle per liter of material	4	15 USgal
Tightness packings :	Flow (20 cycles).	4,8 l	1.27 USgal
Bellows : polyethylene	Maximum air operating pressure	6 bar	88 psi
Upper fixed : GT seal (polyethylene)	Maximum discharge pressure	390 bar	5656 psi
Lower, mobile : GT seal(polyethylene)	Weighted sound pressure (LAeq)	80.2 dBa*	80.2 dBa*
	Maximum operating temperature	50° C	122° F

Weight : Wall mounted pump with suction rod 120 kg / 265 lb
 Cart mounted pump 150 kg / 330 lb

* **Test conditions - Noise level :**

- Test duration : 30 s,
- Motor air pressure : 6 bar,
- Material used : water,
- Flow rate : Pump adjusted at 20 cycles/minute

▪ **FITTINGS**

		Bare pump	Pump assembly
Air	Inlet	F 3/4 BSP (valve)	F 3/4 BSP (valve)
Fluid	Inlet	F 1" BSP	Fitting MM 1" - 38x150 + suction rod (fitting F 38x150)
	Outlet	F 3/4 NPS	# 8 JIC (Male 3/4 JIC) (filter outlet)

▪ **HOSES WITH FITTINGS**

Pump air supply hose (minimum Ø for a 5 m / 16.5 ft length) : Ø 20 mm / 3/4 dia.
 AIRLESS fluid hose (between pump fluid outlet and gun) : Ø 9.52 mm int. / Ø 3/8 ID.

▪ **DIMENSIONS OF THE PUMP, MODEL 40F260**

Ind.	mm	"	Ind.	mm	"	Ind.	mm	"
A	1460	57.5	B	1165	45.86	C	725	28.54
D	390	15.35	E	1120	44.1	F	510	20.07
G	∅ 300	∅ 11.8 -13/16	H	530	20.86	I	414	16.30
J	180	7.1						

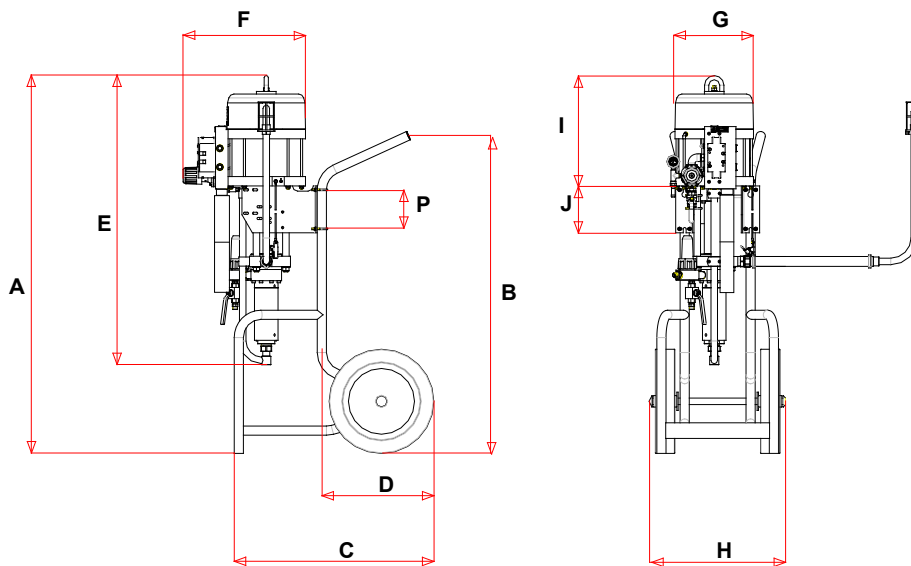

▪ **DIMENSIONS OF THE PUMP, MODEL 65F260**

Ind.	mm	"	Ind.	mm	"	Ind.	mm	"
A	1480	58.27	B	1165	45.86	C	725	28.54
D	390	15.35	E	1160	45.67	F	575	22.64
G	∅ 380	∅	H	530	20.86	I	470	18.50
J	180	7.08	K	485	19.10			

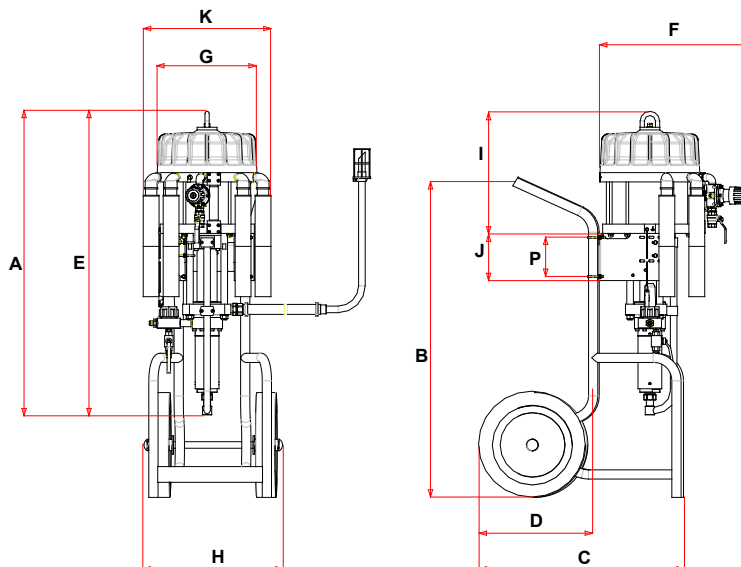

▪ WALL MOUNTED BRACKET OF THE PUMPS

Ind.	mm	"	Ind.	mm	"	Ind.	mm	"
L	288	11.34	M	107.5	4.23	N	251	9.9
O	321	12.64	P	150	5.90	Q	70	2.75
R	35	1.38	S	17	0.67	T	15	0.59
U	7 x 15	0.27 x 0.59	V	∅ 11	∅ 0.43 - 7/16	W	∅ 22	∅ 0.87 - 7/8
X	∅ 11	∅ 0.43 - 7/16	Y	18	0.71			

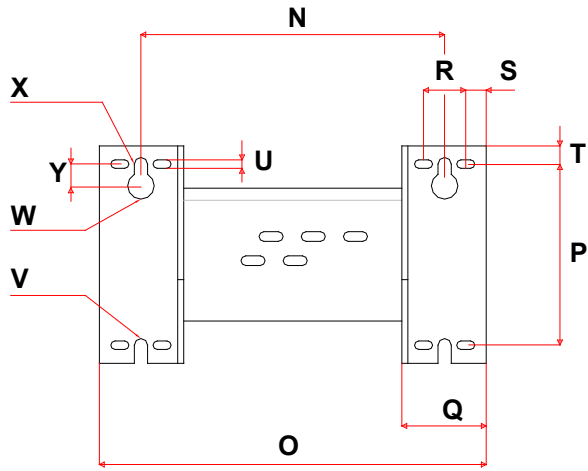

Front view

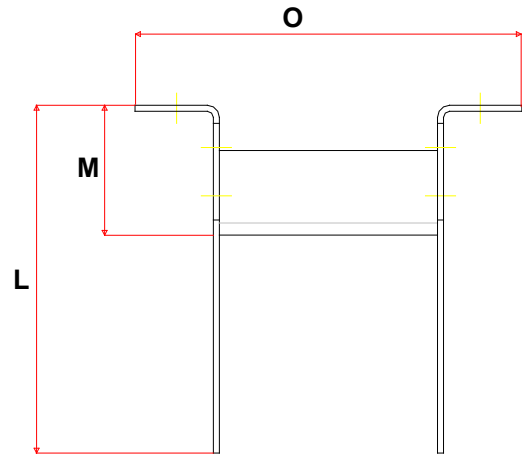

Above view

3. INSTALLATION

The pumps are designed to be installed in a spray booth.

- DESCRIPTION OF THE LABEL MARKING

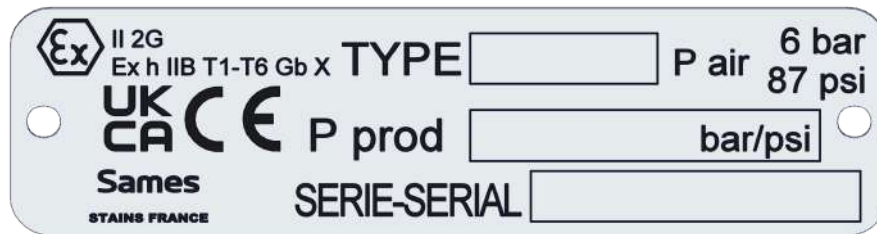

Description	
Sames	Manufacturer's brand
STAINS FRANCE	Manufacturer's address
Ex II 2 G	<p>Ex : Use in explosive area</p> <p>II: Group II 2: Category 2</p> <p>Surface equipment intended for use in environment where explosive atmospheres due to gases, vapors, mists are likely to occur occasionally during normal operation.</p> <p>G: Gas</p>
Ex h IIB T1-T6	<p>Ex: Marking of conformity to European standards</p> <p>h: Protection mode for non-electrical devices</p> <p>IIB: Reference gas for equipment qualification</p> <p>T1-T6: Temperature class range</p>
Gb	Gb : Equipment protection level (gas Zone 1)
X	X : Special conditions apply to the use of the safe operation. Refer to the instructions in the instruction manuals that accompany this product.
UKCA	UK CA : UK Conformity Assessment Marking required for certain products placed on the market in Great Britain (England, Wales, Scotland) on January 2021
CE	CE : European conformity
TYPE	Pump model
P prod : xx bar / xx psi	Maximum fluid pressure at the pump outlet
P air : 6 bar / 87 psi	Maximum air supply pressure of the pump motor
SERIE / SERIAL	Number given by Sames . The two first numbers indicate the manufacturing year.

- TEMPERATURE CLASS - PUMPS, MODEL 40F260 & 65F260

Temperature class	Maximum surface temperature
T5	100° C / 212°F

■ INSTALLATION DIAGRAM

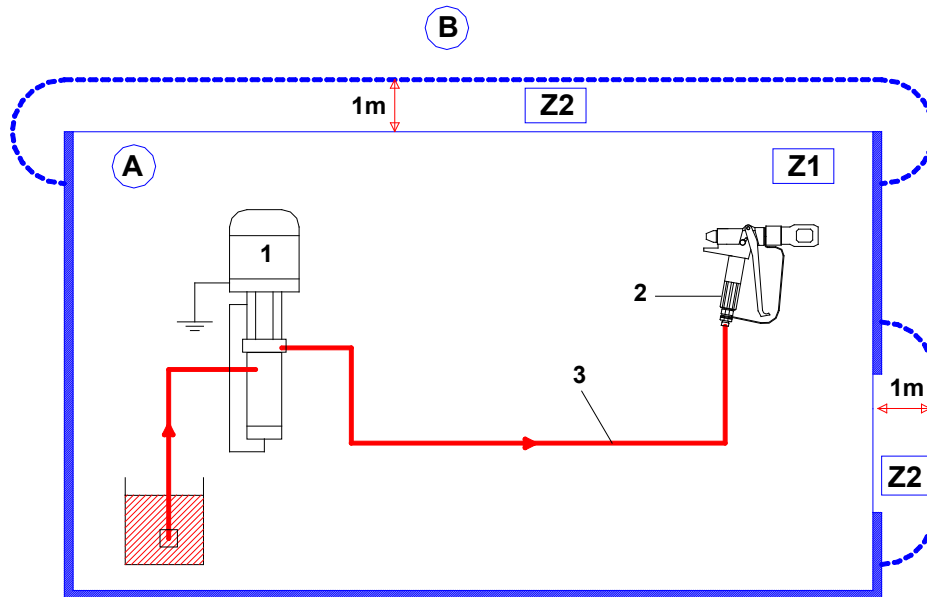

Ind.	Description
A	Explosive area : Area 1 (Z1) or Area 2 (Z2) : spray booth
B	Non explosive area

Ind.	Description
1	Pump
2	Gun
3	Conductive Airless hose



The 1 m / 39.37" distance indicated in this diagram is given for information purposes only and hold harmless to Sames.

The exact delimitation of the zones is the express responsibility of the user, depending on the materials used, the environment and the conditions of use.

The 1 m / 39.37" distance can be modified if the analysis conducted by the user requires it.



NB: Choose the appropriate pump to ensure that the working pressure supplied is suitable for the selected gun.