



PaintCare ePCS-20

Maintenance Installation



II2G Ex h IIB T6 Gb X

Equipment references 151700520-151700620

User manual 582187110

2021-05-03

Index A

SAMES KREMLIN SAS



13 Chemin de Malacher
38240 Meylan



www.sames-kremlin.com



33 (0)4 76 41 60 60

Any communication or reproduction of this document, in any form whatsoever, and any exploitation or communication of its contents are prohibited, unless expressly authorized in writing by **manufacturer**.

The descriptions and characteristics contained in this document are subject to change without prior notice. **Manufacturer** 2021

Manufacture Doc No. 99988152EN-SAM Rev.:1.0

Table of Contents

1	General description	7
1.1	About this Installation and Operating Manual	7
1.2	Use of the Installation and Service Manual	7
1.3	Structure of the Installation and Service Manual	8
1.4	Requirements imposed on personnel.....	9
1.5	Directional and position indications	10
2	Safety notices.....	11
2.1	Safety symbols in this Installation and Service Manual.....	11
2.2	General safety notices.....	12
2.3	Safety instructions concerning installation and service tasks.....	14
3	Prerequisite for working on the pump	19
4	Cover of the Piston pump	20
4.1	Dismounting the side Cover.....	20
4.2	Mounting the side Cover.....	21
4.3	Dismounting the top Cover.....	22
4.4	Mounting the top Cover.....	23
5	Replacing the piston seal.....	24
5.1	Dismounting the cylinder cover	24
5.2	Mounting the cylinder cover	25
5.3	Replacing the piston seals	26
6	Replacing the media valves.....	27
6.1	Dismounting the media valves in the cylinder block.....	27
6.2	Assembly of the media valves in the cylinder block.....	28
6.3	Removing the media valves in the cylinder cover	29
6.4	Assembly of the media valves in the pump head	30
7	Spare parts ePCS-20 with and without motor	32
8	Appendix	33
8.1	Assembly drawing – pump unit	33
8.2	Exploded-view drawing – pump unit.....	34

Evolution table

Subject	Revision	Date
PaintCare ePCS-20	A	09 09 2021

Dear customer, you have just acquired your new equipment and we thank you for it.

We have taken the greatest care, from design to manufacturing, to ensure that this equipment gives you complete satisfaction.

For a good use and an optimal availability, we invite you to read this instruction manual carefully before putting your equipment into service.

Manufacture:

Timmer GmbH

Dieselstraße 37

48485 Neuenkirchen

Germany

Warranty

SAMES KREMLIN grants a contractual warranty for a period of twelve (12) months from the date of availability to the Customer provided that the conditions of use indicated in this technical manual are complied with.

In order to be implemented, the warranty claim must define precisely, in writing the malfunction in question, must be accompanied by the defective Material and/or component, and must be informed of the conditions of acquisition by the Customer of the Material from **SAMES KREMLIN**.

SAMES KREMLIN will only accept or refuse the implementation of the warranty after analysis of the "defective" Material. The warranty granted by **SAMES KREMLIN** is limited to the replacement of the Material in its entirety or to the partial replacement of the defective component.

SAMES KREMLIN will only bear the cost of the parts necessary to replace the defective Material.

No guarantee will be granted by **SAMES KREMLIN**:

- For defects and deteriorations resulting from abnormal conditions of storage and/or conservation at the Customer's premises or for maintenance or use of the Equipment not conforming to the rules of art or not respecting the prescriptions of the present technical manual given to the Customer by **SAMES KREMLIN**,

- For defects and damage resulting from replacement parts not approved by **SAMES KREMLIN** or which the Customer, has modified,

























- For all damages resulting from negligence or lack of supervision

On behalf of the Customer,

- In the event of normal wear and tear of the Equipment and/or its components or in the event of

Deterioration or accident resulting from faulty and/or abnormal use thereof.

Meanings of pictograms

			
Danger : general signal (user)	Danger: high pressure	Explosive materials	Danger: Electricity
			
Toxic materials	Corrosive materials	Harmful or irritating materials	Danger : pinching, crushing
			
Risk of media emanation	Danger: hot rooms or surfaces	Danger: automatic start, moving parts	Danger: risk of flammability
			
General Obligation	Grounding	Refer to manual/instruction leaflet	Gloves must be worn
			
Protective helmet	Hearing protection	Mandatory respiratory protection	Safety footwear
			
Protective clothing	Protective visor	Wearing of glasses is mandatory	Material recycling

1 General description

This section provides information about the Installation and Service Manual as well as general safety notices for handling the Piston pump.

1.1 About this Installation and Operating Manual

This Installation and Service Manual is a central part of the user documentation for the Piston pump.

The notices, data and instructions contained in the Installation and Service Manual must be complied with.

This Installation and Service Manual applies only to the media specified on the cover sheet.

1.2 Use of the Installation and Service Manual

This Operator Installation and Service Manual is only valid in conjunction with the operating manual for the Piston pump. The notes, data and instructions contained in the operating manual for the Piston pump must be complied with.

Work not described in these instructions can only be carried out by the manufacturer or by personnel trained by the manufacturer.

The Installation and Service Manual must be supplemented with instructions on the basis of existing national regulations on accident prevention and environmental protection.

The Installation and Service Manual must be read and applied by any person instructed to carry out one of the tasks described in this Installation and Service Manual.

In addition to the Installation and Service Manual and the binding regulations on accident prevention that are in force in the country of use and at the implementation site, the accepted technical rules for safe and proper work must also be complied with.

1.3 Structure of the Installation and Service Manual

Safety-relevant notices are indicated by appropriate symbols and **bold typeface**.

Listings

Listings of characteristics in arbitrary, not necessarily mandatory sequence are indicated by a dot. For example:

- Characteristic A
 - Characteristic B
 - o Secondary characteristics to characteristic B
-

Sequences

Work steps that must be completed in the specified sequence are numbered and the result of each step is shown in italics.

For example:

1. Step 1

Result of Step 1

2. Step 2

2.1 Sub-step of Step 2 to be carried out

Note: Mounting is usually carried out in the reverse order of dismounting. If this is not possible (e.g. screws are tightened in a special order with a special torque), the sequence of the assembly process will be described.

1.4 Requirements imposed on personnel

All personnel assigned to work on the Piston pump described in this Installation and Service Manual are obligated before starting work:

- To comply with the general regulations regarding occupational health and safety and accident prevention.
- To read the safety instructions and warnings in this Installation and Service Manual and to confirm with their signature that they have understood them.
- To wear personal / workstation-related protective clothing and equipment that ensures occupational health and safety, or to use these items, to the extent required for safety.
- To comply with the defined competencies.
- To have been trained or instructed and their responsibilities for operation, set-up, maintenance and repair must have been clearly defined.

For example, only a qualified specialist or instructed persons under the supervision of such a qualified specialist are allowed to perform tasks on the electrical equipment of the Piston pump and only in accordance with the applicable technical rules.

Unauthorized access is prohibited.

All persons working on the piston pump must at least meet the following points:

- Physically, sensory and mentally capable of carrying out the work,
 - instructed in the residual risks
 - of full age (at least 18 years),
 - qualified and authorized specialists in the fields mechanics, hydraulics electrical engineering, explosion proof and pumps technologies.
-

1.5 Directional and position indications

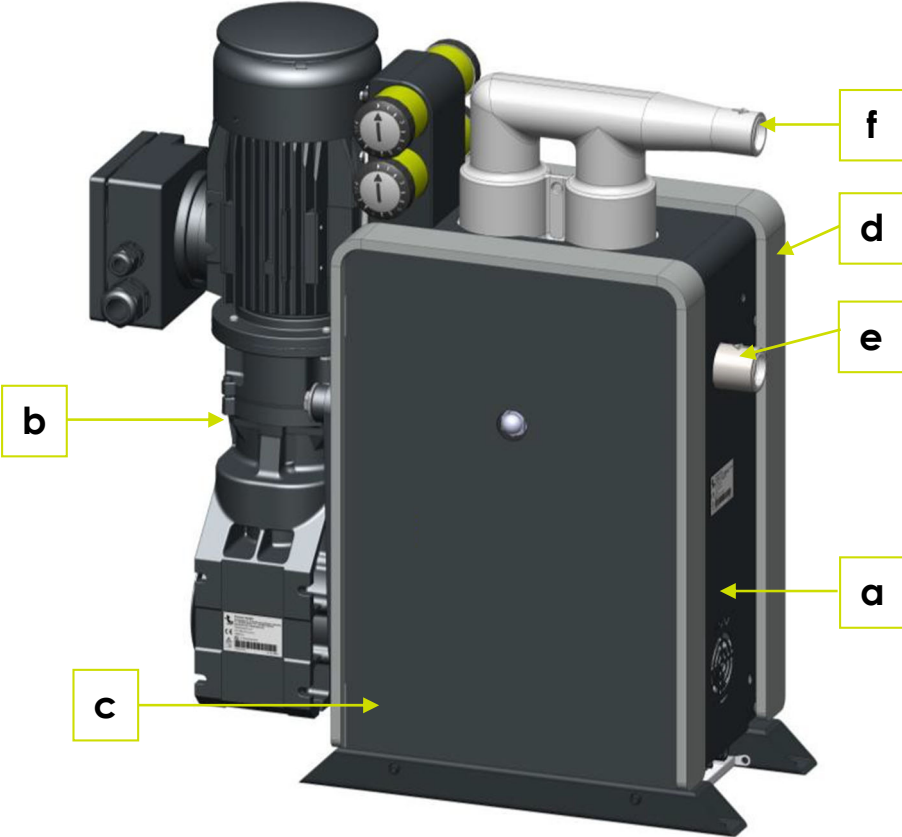

Figure 1 Directional and positional indications

Item	Description	Item	Description
a	Front	b	Rear
c	Right side	d	Left side
e	Inlet opening/supply connection	f	Outlet opening/consumer connection

2 Safety notices

2.1 Safety symbols in this Installation and Service Manual

**Danger**

indicates an imminent danger that will result in severe or fatal bodily injury.

**Warning**

indicates a potentially dangerous situation that can result in severe or fatal bodily injury.

**Caution**

Indicates a potentially dangerous situation that can result in minor injuries.

**Note**

indicates a potentially dangerous situation that can result in material damage or environmental damage.

This signal word is also used for application instructions and other useful information.

2.2 General safety notices

Danger for personnel and the machine



- Comply with all safety and hazard notices on the Piston pump and keep safety and hazard notices in a complete and legible condition.
 - Note the intended use and the possible types of misuse cited in the operating manual for the piston pump.
 - Comply with all general and specific safety notices in this Installation and Service Manual, the operating manual for the Piston pump and the manuals of the third-party manufacturers.
 - Refrain from any unsafe working method.
 - Keep the Installation and Service Manual on hand at all times.
 - Comply with the applicable occupational health and safety regulations (DGUV regulations).
 - Comply with the technical rules for hazardous substances (TRGS), in particular technical rules of the 700 and 800 series (protection against fire and explosion).
 - Comply with the technical rules for operational safety (TRBS).
 - Comply with the relevant occupational health regulations.
 - Comply with country-specific regulations.
 - Comply with the manufacturer's information (safety data sheets) for operating materials and auxiliary materials.
-

Risk of explosion in potentially explosive atmospheres



- Comply with the safety data sheets for the pumped media.
- Careful handling of highly flammable media.
- Comply with the operating instructions issued by the owner.



- Fire, naked light and smoking are prohibited in potentially explosive atmospheres.
- Keep ignition sources away.



- In the entire potentially explosive atmosphere, activities are prohibited that can result in heating, electrostatic charging, electrical or mechanical sparks or development of fire.

Risk of injury due to unavailability of protective equipment



- Wear the protective equipment specified by the company for all tasks on the Piston pump.



- Wear personal protective clothing.

- Comply with the information in the safety data sheets concerning the pumped media.



- Wear ESD-compliant clothing.

- Wear ESD-compliant safety shoes.
-

2.3 Safety instructions concerning installation and service tasks

Danger to personnel and the machine



- Only qualified personnel are allowed to perform the tasks described in this Installation and Service Manual.
 - Comply with the safety instructions in this Installation and Service Manual, in the operating manual for the Piston pump and in the operating manuals of third-party manufacturers before carrying out maintenance and repair tasks.
 - Cordon off the area, ensuring ample space that may be required for the tasks.
 - Before starting the tasks, switch off the Piston pump and prevent it from being switched on unexpectedly.
 - Execute tasks only when the equipment is de-pressurised and de-energised.
 - Execute tasks, for which safety devices must be rendered inoperable and/or Cover elements must be removed, with the utmost caution. Clearly define responsibilities and work areas.
 - Reattach all removed safety devices and / or Cover elements immediately after concluding the tasks.
 - Be careful and alert in the entire work area of the Piston pump.
 - Comply with and implement the maintenance intervals and maintenance tasks that must be executed as described in the operating manual for the Piston pump.
 - The instructions in the operating manual for initial commissioning must be observed and complied with.
-

Risk of explosion due to improperly performed tasks

- Only qualified personnel are allowed to perform the tasks described in this Installation and Service Manual.
- Only qualified personnel are allowed to perform repair tasks.
- A qualified electrician must carry out all tasks on the electrical equipment of the Piston pump, as well as its installation, commissioning, maintenance and repair in accordance with the circuit diagram and with particular consideration of the applicable regulations for potentially explosive atmospheres.
- Before starting the tasks, switch off the Piston pump and prevent it from being switched on unexpectedly.
- Execute tasks only when the equipment is de-pressurised and de-energised.
- Comply with the operating instructions and processes of the owner, for example, procedures such as permits for working with sources of ignition in areas with a potentially explosive atmosphere.
- Carry out the tasks described in this Installation and Service Manual outside of the potentially explosive atmosphere.
- Use only original spare parts.
- Do not modify the Piston pump without authorisation.
- Before reinstalling the Piston pump in the potentially explosive area, ensure that an explosive atmosphere is not present in the area.
- Only have a specialist with explosion protection expertise perform electrical installations; electrical installations must be executed in accordance with the circuit diagram.
- After the tasks, remove tools and other objects from the Piston pump.
- Ensure that the system components are properly supported to avoid weight load of the pump parts.
- Do not use the Piston pump as a support for the piping system.
- Use suitable hose clamps to attach intake hose and delivery hose.
- The direction of flow is indicated by arrows on the pump housing. Pay strict attention to these arrows; do not remove them, keep them in faultless, recognisable condition.
- Carry out a function test (leak tightness, running behaviour, etc.) before recommissioning with non-hazardous media and under exclusion of explosive atmospheres.

Risk of explosion due to static discharge

- Remove the connection for potential equalisation only when the bottom fastening screws for fixing the Piston pump are removed and the Piston pump must be transported out of the explosive atmosphere for the tasks.
- Before re-commissioning, properly integrate the Piston pump in the local equipotential bonding via a protective conductor on the connection provided for this purpose.
- If the conductive Cover is removed from the pump, the pump loses its contact with earth. To prevent electrostatic charges, ESD safety footwear must be worn in the potentially explosive atmosphere and the Cover must be placed only on the conductive floor.
- Floors in potentially explosive atmospheres where people are present must be designed in such a manner that people do not become dangerously charged when wearing conductive footwear.
- Do not wear metallic objects, such as watches or jewellery that may pose a hazard of electrostatic discharge.
- Wear ESD safety footwear.

Danger for personnel due to electric shock

- Only qualified personnel are allowed maintain and repair the Piston pump; maintenance and repair must be executed in accordance with the circuit diagram.
 - Only have a specialist perform electrical installations; electrical installations must be executed in accordance with the circuit diagram.
 - After tasks, close the control cabinet and all terminal boxes and connection boxes.
 - Do not touch live parts.
 - Before any intervention in the electric wiring or opening the control cabinet, switch off the Piston pump and prevent the main switch from being switched on without authorisation.
 - Execute tasks in de-energised status.
 - De-energise the affected electrical component.
 - Use only voltage-insulated tools.
 - Regularly inspect and test the electrical equipment of the Piston pump. Eliminate loose connections, cables with damaged insulation or other defects immediately.
-

Damage to the Piston Pump and flammable liquids escaping due to incorrect torque applied to the cylinder cover screws



The prescribed tightening torque for the screws of the cylinder cover is 40 Nm. To prevent damage to and leaks of the Piston pump, do not exceed this value.

- Tighten the cylinder screws of the cylinder cover to 40 Nm.
- Use a calibrated torque spanner.

Risk of injury when working on fluid-conveying parts of the Piston pump



Media escaping under high pressure develop unexpectedly high forces and can cause severe injuries.

- Only an authorised specialist is allowed to perform tasks on fluid-conveying parts of the Piston pump.
- Switch off the Piston pump for set-up and service tasks, for maintenance and fault rectification and prevent it from being switched on unexpectedly.
- Depressurise fluid-conveying parts before performing tasks.
- Lay out and mount fluid-conveying parts properly.
- Avoid skin contact. Wear personal protective equipment.
- Seek immediate medical attention for injuries caused by fluids escaping under high pressure. The most severe infections or bodily reactions can be the result, if medical help is not provided immediately.

Danger due to hot surfaces



- Do not touch the hot motor.
- Allow motor to cool down before starting maintenance tasks.

Note

Use flexible connections (e.g., hose connections) for intake and discharge. The flexible connections prevent transmission of vibration to the piping system.

Environmental pollution

- Dispose of operating materials and auxiliary materials in a manner that is safe and eco-friendly.
- Comply with manufacturer's instructions.

Health hazard due to emission of harmful media when performing tasks on wetted components of the Piston pump

- Pumped media and media residues in the pump can be harmful.
 - Comply with the instructions of the safety data sheet for the pumped product.
 - Carefully flush the pump before performing tasks.
 - Wear personal protective equipment.
 - Ensure adequate ventilation.
-

3 Prerequisite for working on the pump

- Pump flushed, cleaned of pumped hazardous substances and emptied.
 - Lines at the suction and pressure connections of the piston pump are dismantled.
 - The pump is de-energised and depressurised and secured against being switched on again.
 - The piston pump has been removed from the Ex zone.
-

4 Cover of the Piston pump

4.1 Dismounting the side Cover



Fig. 4-1: Front



Fig. 4-2: Rear

Prerequisites:

See section 3: Prerequisite for working on the pump.

Work steps:

1. On the front (Fig. 4-1: Front) of the Piston pump unscrew the two hexagon socket screws M8x40 5 turns with using a 5 mm Allen key (↻).
2. On the rear (Fig. 4-2: Rear) of the Piston pump unscrew the two hexagon socket screws M8x40 5 turns with using a 5 mm Allen key (↻).
3. Take off the side Cover elements (1) in the direction of the arrow (Fig. 4-3: Dismounting the side Cover).

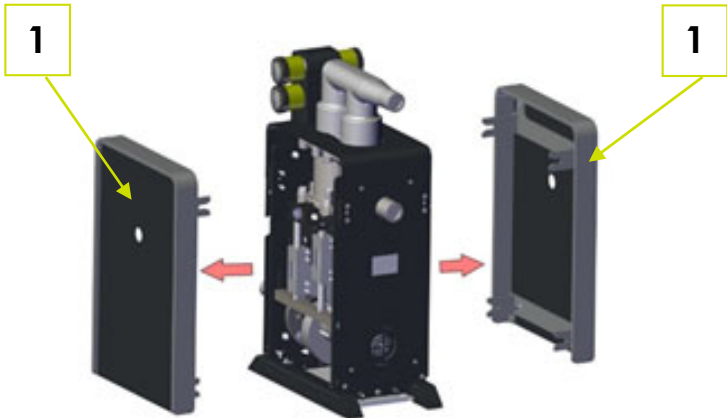

Fig. 4-3: Dismounting the side Cover

The side Cover elements are dismounted

4.2 Mounting the side Cover

Note

The side Cover elements are installed in the reverse order described in section 4.1 "Dismounting the side Cover" (tightening torque 16 Nm).

The side Cover elements are mounted.

4.3 Dismounting the top Cover

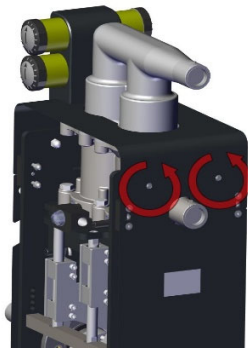

Fig. 4-4: Front

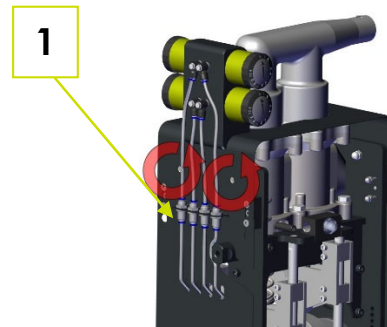

Fig. 4-5: Rear

Prerequisites:

- Side Cover elements must be dismantled (see section 4.1 "Dismounting the side Cover")

Work steps:

1. On the front of the Piston pump (Fig. 4-4: Front) unscrew the two hexagon socket screws M6x50 5 turns using a 4 mm Allen key (↻).
2. On the rear of the Piston pump (Fig. 4-5: Rear) unscrew the two hexagon socket screws M6x50, 5 turns using a 4 mm Allen key (↻).
3. Turn off permanent lubricator.
4. Disconnect the lubrication lines (Fig. 4-5: Rear) from the push-in fittings (1).

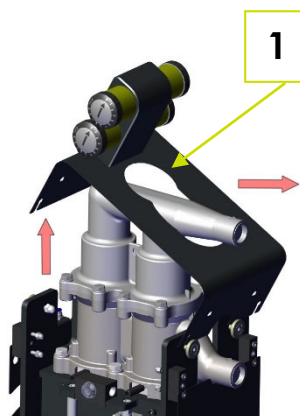

Fig. 4-6: Dismounting the top Cover

5. Dismount the top Cover (1) in the direction of the arrow (Fig. 4-6: Dismounting the top Cover).

Note

Lubricants leak out at the separation points after the lubricant lines have been loosened!

- Switch off the permanent lubricator
- Collect any lubricants that run out.
- Clean the affected components.

The top Cover is dismounted.

4.4 Mounting the top Cover

Note

The top Cover is mounted in the reverse order described in section 4.3 "Dismounting the top Cover" (tightening torque 10 Nm).

Activate permanent lubricator.

The top Cover is mounted.

5 Replacing the piston seal

5.1 Dismounting the cylinder cover

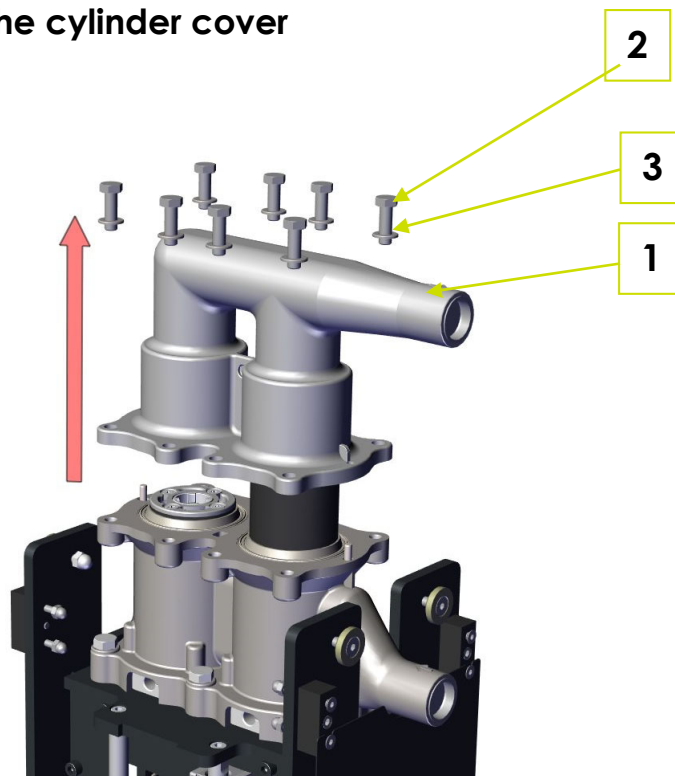

Fig. 5-1: Dismounting the cylinder cover

Prerequisites:

- See section 3: Prerequisite for working on the pump

Danger due to escaping product



- Collect any escaping product.
- Clean affected components.

Work steps:

1. Unscrew all hexagon screws M10x30 (2) with a 17 mm ring spanner.
2. Take off the cylinder cover (1) upward in the direction of the arrow (Fig. 5-2: Dismounting the cylinder cover).

The cylinder cover is dismounted.

5.2 Mounting the cylinder cover

Prerequisites:

- Cylinder cover of the Piston pump must be dismantled (see section 5.3 "Dismounting the of the cylinder cover").
- Piston pump must be removed from the Ex zone.

Work steps:

1. Clean the cylinder cover (1) and fit it back on the cylinder block (Fig. 5-2: Mounting the cylinder cover).
2. Hand-tighten all eight M10x30 hexagon screws (2) greased with assembly grease (Renolit Unitemp 2), with the washers A10.5 (3).
3. Tighten all eight hexagon screws M10x30 (2) to a torque of 40 Nm in the sequence 2-7-3-8-1-6-9-4 (Fig. 5-3: Numbering of the fillister head screws).

The cylinder cover is mounted.

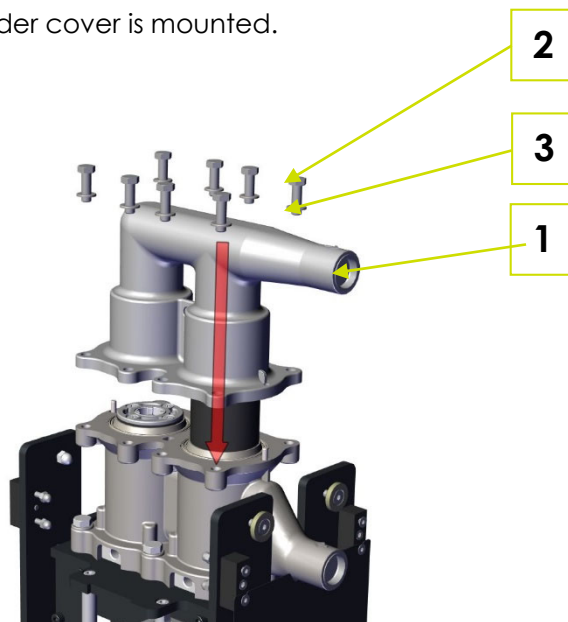

Fig. 5-2: Mounting the cylinder cover

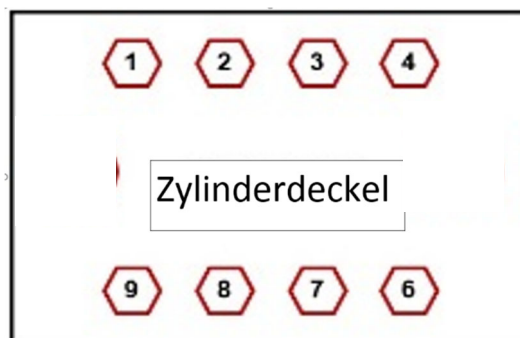

Fig. 5-3: Numbering of the fillister head screws

5.3 Replacing the piston seals

Prerequisites:

- The cylinder cover must be dismantled (see section 5.3 "Dismounting the of the cylinder cover").

Work steps:

1. Use an O-ring hook or a similar tool to remove both composite piston seals (1).
2. Clean the support surfaces of the composite piston seals.
3. Place clamping supports (3) in the seal body (4) (this assembly becomes the composite piston seal)

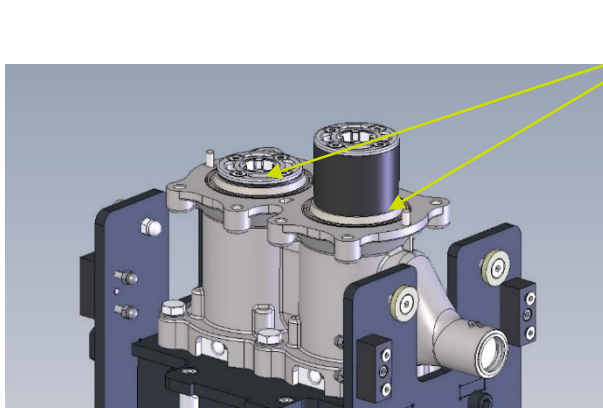

Fig. 5-4: Replacement of the composite piston seal

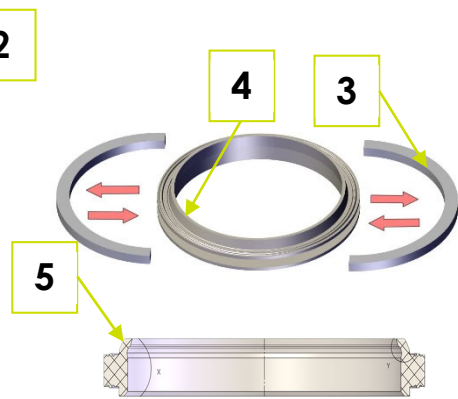

Fig. 5-6: Structure of the composite piston seal

4. Press the composite piston seals (1) into their position above the pistons. In installed status the sealing lip (5) points upward
5. Clean the surface of the cylinder block.

Note The new piston seals are slightly pre-tensioned and can only be mounted with a light expenditure of force.

Incorrectly fitted seals lead to a reduced delivery rate.

6 Replacing the media valves

6.1 Dismounting the media valves in the cylinder block

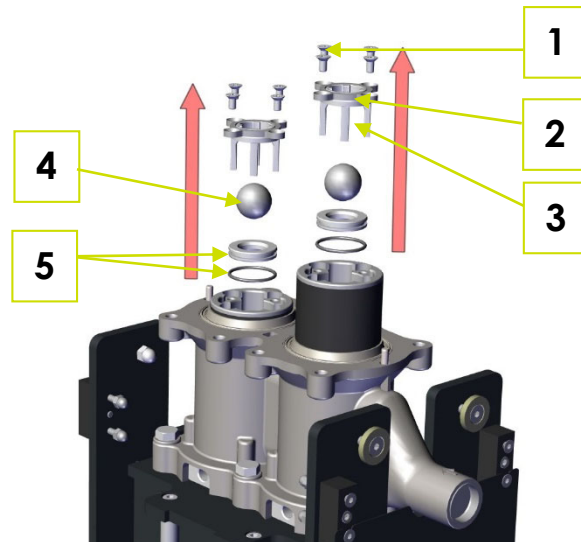

Fig. 6-1: Dismounting the media valves in the cylinder block

Prerequisites:

- Cover elements must be dismantled (see section 4 "Cover of the Piston pump").
- Cylinder cover must be dismantled (see section 5.3 "Dismounting the cylinder cover").

Work steps:

1. Unscrew all eight countersunk head screws M6x12 (1) with a T30 Torx spanner (Fig. 6-1: Dismounting the media valves in the cylinder block).
2. Take out both retaining stars (2).
3. Take out both cages (3) and balls (4).
4. Take out both valve seats (5) with the O-rings.

The media valves are dismantled.

Note

The O-rings must not be reused; they must be replaced with new ones at assembly.

6.2 Assembly of the media valves in the cylinder block

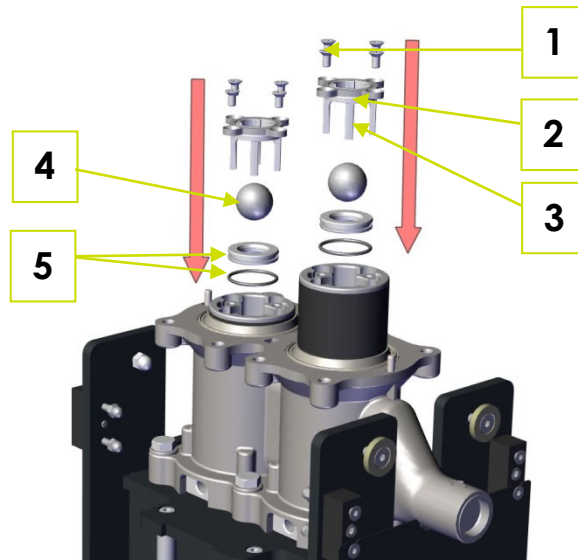

Fig. 6-2: Assembly of the media valves in the cylinder block

Prerequisites:

- Cylinder cover must be dismantled (see section 5.3 "Dismounting the cylinder cover").
- Media valves must be dismantled (see section 6.1 "Dismounting the media valves in the cylinder block").

Work steps:

1. Insert new valve seats (5), greased with Renolit Unitemp 2 with new O-rings (Fig. 6-2: Assembly of the media valves in the cylinder block).
2. Insert both new balls (4) and cages (3).
3. Insert both retaining stars (2).
4. Clean all eight countersunk head screws M6x12 (1) and grease them with Renolit Unitemp 2.
5. Loosely screw in countersunk head screws M6x12 until they rest in the counter bores.

Note

Avoid tilting the cages (3) when mounting.

6. Tighten countersunk head screws M6x12 crosswise in 20° increments with a T30 Torx torque spanner until the torque of 10 Nm is reached.

The media valves are mounted.

6.3 Removing the media valves in the cylinder cover

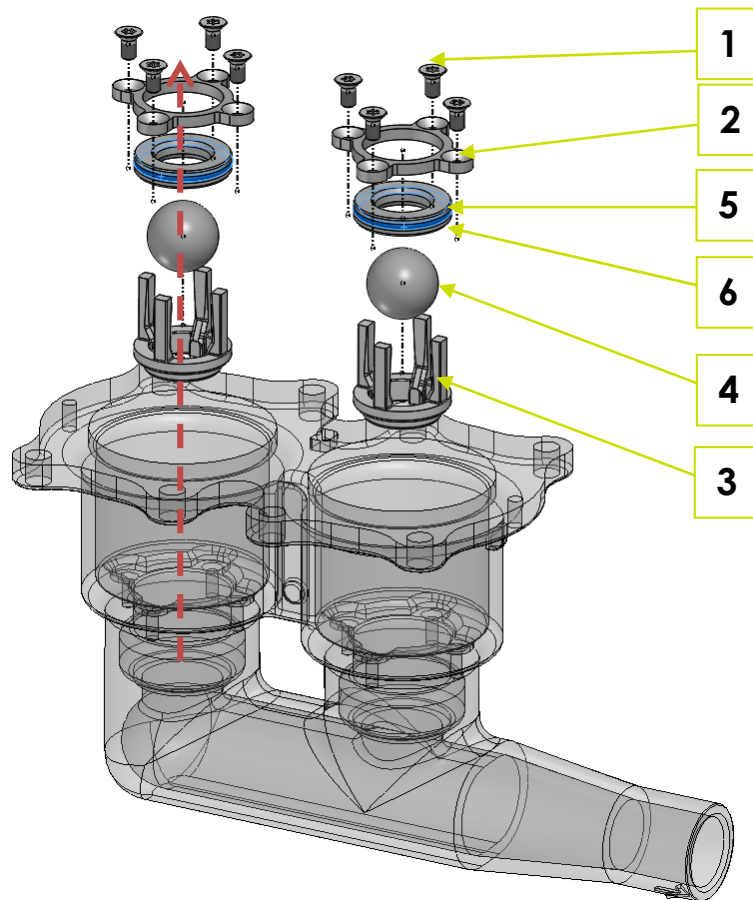

Fig. 6-3: Removing the media valves in the cylinder cover

Prerequisites:

- Cylinder cover must be dismantled (see section 5.3 "Removing the media valves in the cylinder cover").

Work steps:

1. Unscrew all eight countersunk head screws M6x12 (1) with a T30 Torx spanner (Fig. 6-3: Removing the media valves in the cylinder cover).
2. Take out both retaining stars (2).
3. Take out both valve seats (5) with the O-rings (6).
4. Take out both cages (3) and balls (4).

The media valves are dismantled.

Note

The O-rings must not be reused; they must be replaced with new ones at assembly.

6.4 Assembly of the media valves in the pump head

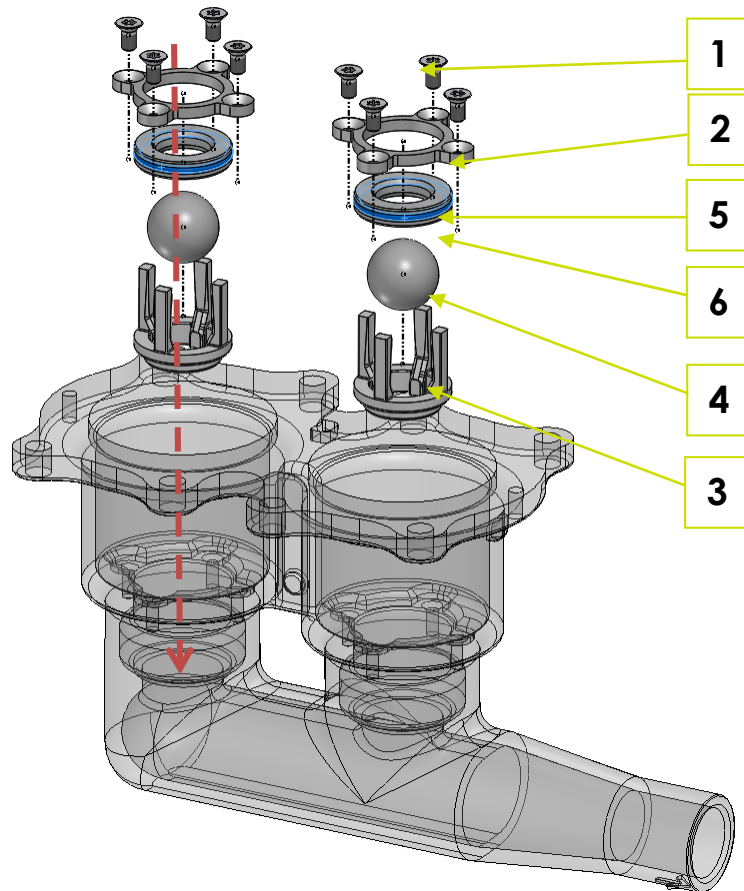

Fig. 6-4: Assembly of the media valves in the pump head

Prerequisites:

- Media valves must be dismantled (see section 6.3 "Removing the media valves in the cylinder cover").

Work steps:

1. Insert both new balls (4) and cages (3).
2. Insert new valve seats (5), greased with Renolit Unitemp 2, with new O-rings (Fig. 6-4: Assembly of the media valves in the pump head).
3. Insert both retaining stars (2).
4. Clean all eight countersunk head screws M6x12 (1) and grease them with Renolit Unitemp 2.
5. Loosely screw in countersunk head screws M6x12 until they rest in the counter bores.

Note

Avoid filling the cages (3) when mounting.

6. Tighten countersunk head screws M6x12 crosswise in 20° increments with a T30 torque spanner until the torque of 10 Nm is reached.

The media valves are mounted.

7 Spare parts ePCS-20 with and without motor

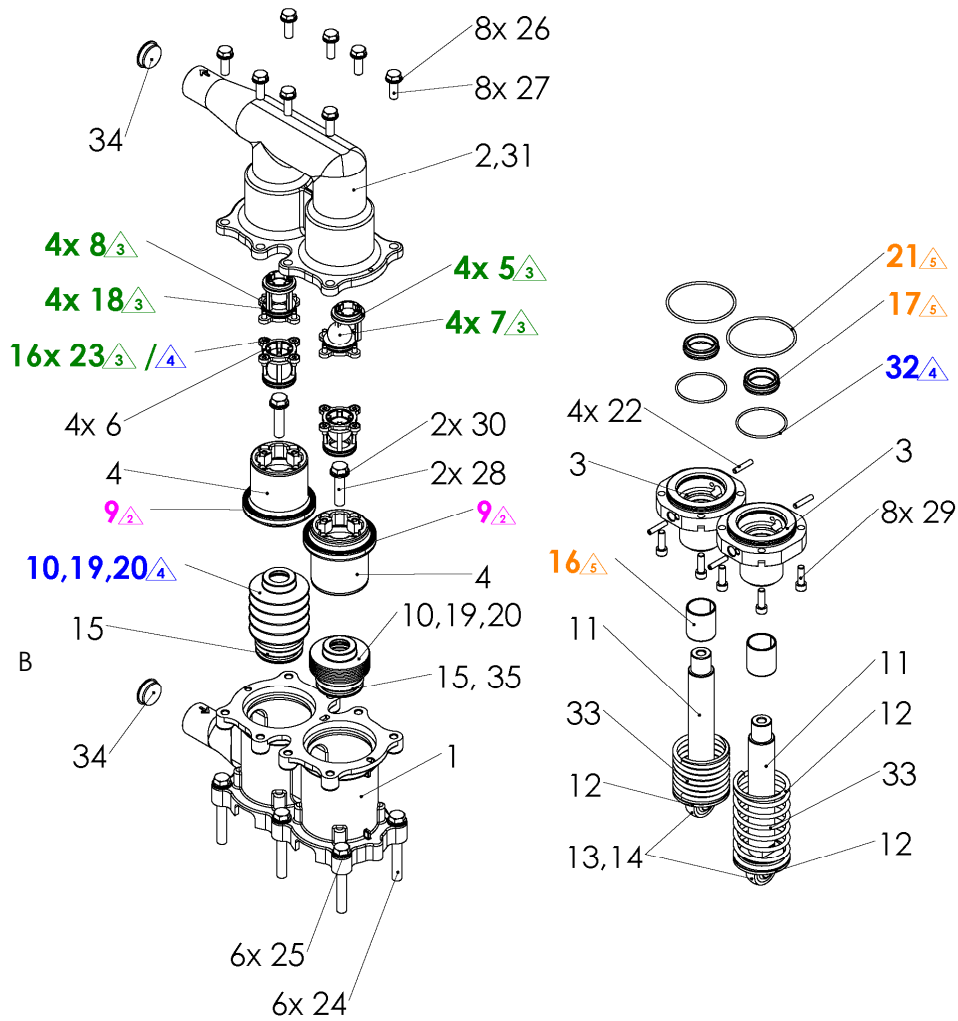

2 Wear part kit piston seal
151700629

3 Wear part kit check valves
151700628

4 Wear part kit bellows
151700627

5 Wear part kit pump unit
151700625
(incl. 151700628 & 151700627)

8 Appendix

8.1 Assembly drawing – pump unit

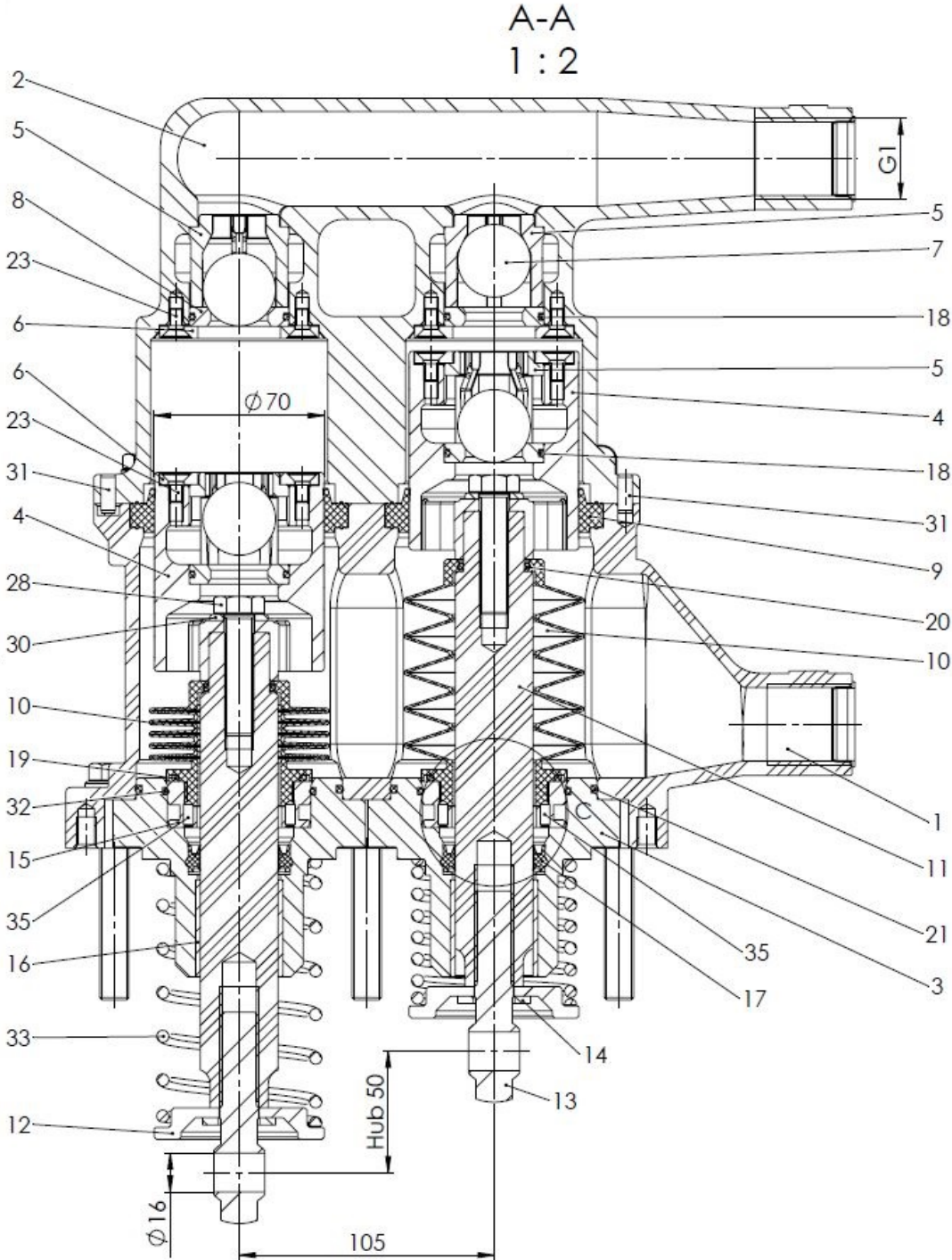

Fig. 8-1: Assembly drawing – pump unit

8.2 Exploded-view drawing – pump unit

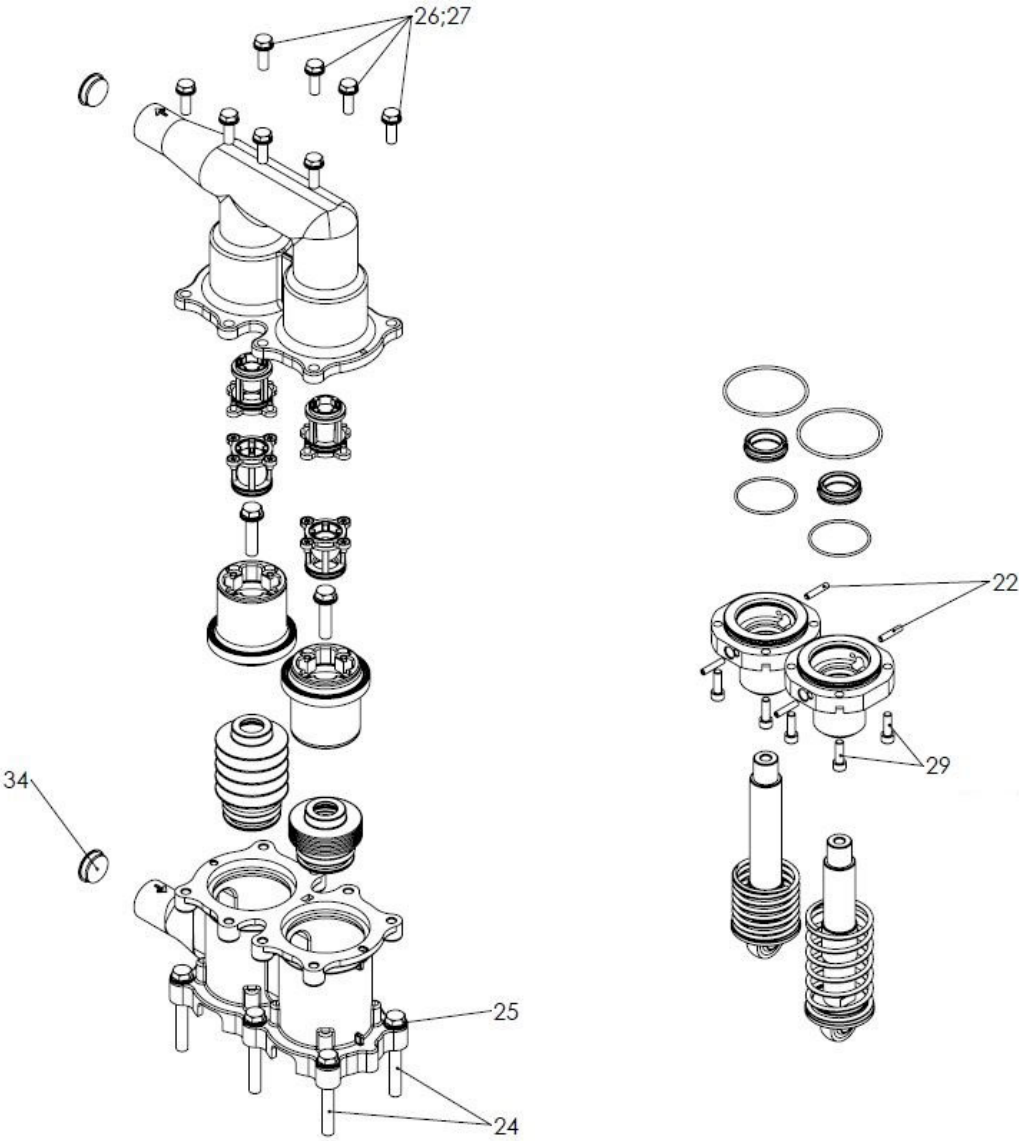

Fig. 8-2: Exploded-view drawing – pump unit

SAMES KREMLIN SAS

13 Chemin de Malacher
38240 Meylan
France

Tel.: 33 (0)4 76 41 60 60
www.sames-kremlin.com
