



PaintCare ePCS-30 PaintCare ePCS-40-60 without motor



II2G Ex h IIB T4 Gb X

Equipment References 151700530-151700540

User manual 582186110

2021-04-29

Index B

Original manual

SAMES KREMLIN SAS



13 Chemin de Malacher
38240 Meylan



www.sames-kremlin.com



33 (0)4 76 41 60 60

Any communication or reproduction of this document, in any form whatsoever, and any exploitation or communication of its contents are prohibited, unless expressly authorized in writing by **manufacture.**

The descriptions and characteristics contained in this document are subject to change without prior notice. **Manufacture** 2021

Manufacture Doc. No: 99988037EN-SAM Rev.:1.1

Table of Contents

1	General description	8
1.1	About this Installation and Operating Manual	8
1.2	Use of the Installation and Operating Manual	8
1.3	Structure of the Installation and Operating Manual	9
1.4	Obligations of the owner	9
1.5	Requirements imposed on personnel	10
1.6	Note on training courses	11
1.7	Direction and position information	11
1.8	Hazards when handling the Machine	12
1.9	Intended use	13
1.9.1	Additional information concerning the intended use of the incomplete machine in accordance with Machinery Directive 2006/42/EC	14
1.9.2	Additional instructions on the intended use of the device in accordance with ATEX Directive 2014/34/EU	15
1.9.3	Additional instructions for pumping product of average conductivity	15
1.10	Misuse	16
1.11	Warranty claims and liability	18
2	Safety notices	19
2.1	Safety symbols in this Installation and Operating Manual	19
2.2	General safety notices	20
2.3	Safety instructions for transport, installation and initial commissioning	24
2.4	Safety notices for operation	26
2.5	Safety instructions concerning set-up tasks, service, maintenance and troubleshooting	27
2.6	Pump marking	31
3	Technical data	32
3.1	Overall system	32
3.2	Product	32
3.2.1	Material of the parts in contact with the product	33
3.3	ATEX marking in accordance with Directive 2014/34/EU for the pump	34
3.4	Identified ignition risks and protective measures	35
3.5	Explosion-proof sub-devices	35
4	Structure and function	36
4.1	Piston Pump complete	36
4.1.1	Drive train	37
4.1.2	Double-joint rocker with lubricating rocker	37
4.1.3	Pump head	38
4.2	Protective devices	40

4.2.1	Emergency stop devices.....	40
4.2.2	Protective cover	40
4.2.3	Seals.....	41
5	Transport, assembly, installation and initial commissioning	42
5.1	Safety notices.....	42
5.2	Unpacking the machine and checking the scope of delivery	43
5.3	Installation of motor and gearbox.....	44
5.4	Installation, connection and initial commissioning	47
5.4.1	Installing, connecting and commissioning the machine	48
6	Operation	51
6.1	Safety notices.....	51
6.2	Operating and control elements	51
6.3	Basic checks before and during operation	52
6.4	Operating the machine	53
6.4.1	Switching on the machine	53
6.4.2	Machine operation	53
6.5	Switching off the machine	53
7	Maintenance and care.....	54
7.1	Safety notices.....	54
7.2	Maintenance table	55
7.3	Flushing the pump	56
8	Troubleshooting.....	58
8.1	Safety notices.....	58
8.2	Faults in the workflow	58
8.3	Fault table.....	59
8.4	Repair	60
9	Storage, dismantling and disposal.....	61
9.1	Safety notices.....	61
9.2	Decommissioning and uninstalling	62
9.3	Storage.....	63
9.4	Disposal	63
10	Appendix	64
10.1	EC Declaration of Incorporation in accordance with EC Machinery Directive 2006/42/EC..	65
10.2	Declaration of Conformity in accordance with ATEX Directive 2014/34/EU	66
10.3	Documentation of third-party manufacturers	64
10.4	Spare parts list	64

Evolution table

Subject	Revision	Date
PaintCare ePCS-30 PaintCare ePCS-40-60 Without motor	A	01 29 2021
PaintCare ePCS-30 PaintCare ePCS-40-60 Without motor	B	09 06 2021

Dear customer, you have just acquired your new equipment and we thank you for it.

We have taken the greatest care, from design to manufacturing, to ensure that this equipment gives you complete satisfaction.

For a good use and an optimal availability, we invite you to read this instruction manual carefully before putting your equipment into service.

Warranty

SAMES KREMLIN grants a contractual warranty for a period of twelve (12) months from the date of availability to the Customer provided that the conditions of use indicated in this technical manual are complied with.

In order to be implemented, the warranty claim must define precisely, in writing the malfunction in question, must be accompanied by the defective Material and/or component, and must be informed of the conditions of acquisition by the Customer of the Material from **SAMES KREMLIN**.

SAMES KREMLIN will only accept or refuse the implementation of the warranty after analysis of the "defective" Material. The warranty granted by **SAMES KREMLIN** is limited to the replacement of the Material in its entirety or to the partial replacement of the defective component.

SAMES KREMLIN will only bear the cost of the parts necessary to replace the defective Material.

No guarantee will be granted by **SAMES KREMLIN**:

























- For defects and deteriorations resulting from abnormal conditions of storage and/or conservation at the Customer's premises or for maintenance or use of the Equipment not conforming to the rules of art or not respecting the prescriptions of the present technical manual given to the Customer by **SAMES KREMLIN**,
- For defects and damage resulting from replacement parts not approved by **SAMES KREMLIN** or which the Customer, has modified,
- For all damages resulting from negligence or lack of supervision

On behalf of the Customer,

- In the event of normal wear and tear of the Equipment and/or its components or in the event of

Deterioration or accident resulting from faulty and/or abnormal use thereof.

Meanings of pictograms

			
Danger : general signal (user)	Danger: high pressure	Explosive materials	Danger: Electricity
			
Toxic materials	Corrosive materials	Harmful or irritating materials	Danger : pinching, crushing
			
Risk of product emanation	Danger: hot rooms or surfaces	Danger: automatic start, moving parts	Danger: risk of flammability
			
General Obligation	Grounding	Refer to manual/instruction leaflet	Gloves must be worn
			
Protective helmet	Hearing protection	Mandatory respiratory protection	Safety footwear
			
Protective clothing	Protective visor	Wearing of glasses is mandatory	Material recycling

1 General description

This section provides information about the installation and operating manual, as well as general safety notices for handling the piston pump.

Hereafter, the piston pump is also referred to as an (incomplete) machine or (atex) device.

1.1 About this installation and operating manual

This installation and operating manual is a central component of the user documentation for the machine. All instructions, data, and regulations contained in the installation and operating manual must be complied with. The installation and operating manual will help you to operate the machine safely and with high availability.

We reserve the right to make technical changes to the presentations and information in the installation and operating manual in the interest of improving the machine.

This installation and operating manual applies only to the product specified on the cover sheet.

1.2 Use of the installation and operating manual

This installation and operating manual is intended to familiarise personnel with the machine and to make use of its intended applications.

The installation and operating manual must be supplemented with instructions on the basis of existing national regulations on accident prevention and environmental protection.

The installation and operating manual must always be available and in a legible form at the installation site of the machine.

The installation and operating manual must be read and applied by every person assigned to work with and on the machine, for example: operation, including set-up, fault rectification, care, disposal of operating and auxiliary materials, maintenance (service and inspection) and/or transport.

In addition to the installation and operating manual and the binding regulations on accident prevention that are in force in the country of use and at the implementation site, the accepted technical rules for safe and proper work must also be complied with.

1.3 Structure of the installation and operating manual

Safety-relevant notices are indicated by appropriate symbols and **bold typeface**.

Listings

Listings of characteristics in arbitrary and not necessarily mandatory order are indicated by a dot.

For example:

- Characteristic a
- Characteristic b
 - o Secondary characteristic to characteristic b

Sequences

Work steps that must be completed in the specified sequence are numbered, and the result of each step is shown in italics.

For example:

1. Step 1
 - o *Result of step 1*
2. Step 2
 - o 2.1 sub-step of step 2 to be carried out.

1.4 Obligations of the owner

The owner is obligated to only allow personnel to work on the machine who:

- Are familiar with the basic regulations for occupational health and safety and accident prevention and have been trained in the handling of the machine.
 - Have read and understood the safety instructions and warnings in this installation and operating manual and have confirmed this with their signature.
 - Have been trained or instructed and whose responsibilities for operation, set-up, maintenance and repair have been clearly defined.
 - Are regularly instructed with regard to complications, hazards and other special rules of conduct.
-

The owner is obligated:

- To comply with and to communicate the general statutory and other binding regulations for accident prevention, environmental protection and the handling of hazardous substances, in supplementation to this installation and operating manual.
- To provide personal protective equipment.
- To define the responsibilities of the machine operator to enable the machine operator to reject instructions of third parties that are detrimental to safety.
- To verify the safety-conscious work of personnel at regular intervals.
- To comply with the statutory regulations in force at the installation site of the machine.

1.5 Requirements imposed on personnel

All personnel assigned to work on the machine are obligated, before taking up their work:

- To comply with the general regulations regarding occupational health and safety and accident prevention.
- To read the safety instructions and warnings in this installation and operating manual and to confirm with their signature that they have understood them.
- To wear personal / workstation-related protective clothing and equipment that ensures occupational health and safety, or to use these items, to the extent required for safety.
- To comply with the defined competencies.

For example, only a qualified specialist or instructed persons under the supervision of such a qualified specialist are allowed to perform tasks on the electrical equipment of the machine and only in accordance with the applicable technical rules.

Unauthorised access is prohibited.

1.6 Note on training courses

Only assign trained or instructed personnel. The responsibilities of personnel for operation, set-up, maintenance and repair must be clearly established.

Personnel in training, being taught, being instructed or who are participating in an apprenticeship program are only allowed to be active on the machine under the permanent supervision of an experienced person.

1.7 Direction and position information

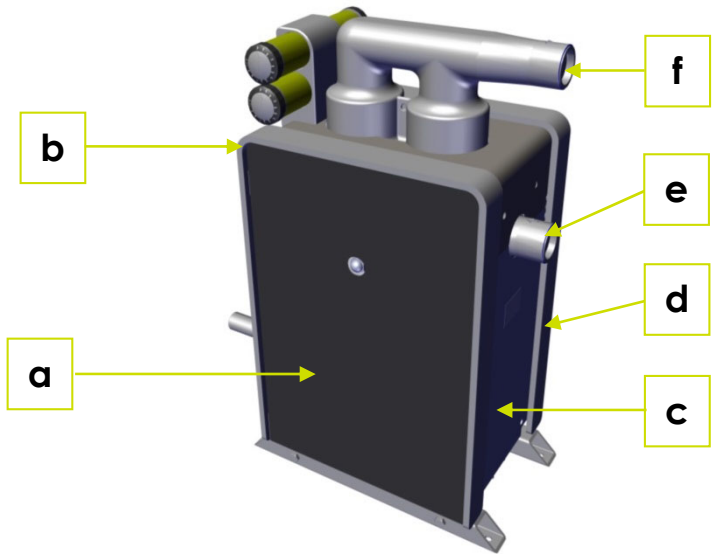

Figure 1 Direction and position information

Item	Designation	Item	Designation
a	Front	b	Left side
c	Right side	d	Rear
e	Inlet opening, supply connection	f	Outlet opening, consumer connection

1.8 Hazards when handling the machine

The machine is manufactured in accordance with the latest engineering standards and acknowledged safety regulations. Nevertheless, danger to the life and limb of the user or a third person or damage to the machine or other property can occur if it is not used properly.

Only operate the machine as intended, and in faultless condition where safety is concerned.

Danger for personnel and the machine



- Only operate the machine when all protective devices and safety-relevant devices, e.g. Detachable protective devices or emergency stop devices, are present and fully functional.
- Rectify faults that can impair safety immediately, or have them rectified immediately.
- Pay attention to the information on residual risks and hazards in section 2 "safety notices".
- Comply with the intended use.
- Comply with the relevant rules issued by the employers' liability insurance association for health and safety at the workplace (bg-rules).
- Comply with the relevant occupational health regulations.
- Comply with the generally accepted technical safety rules.
- Comply with country-specific regulations.
- Comply with the manufacturer's information (safety data sheets) for operating materials and auxiliary materials.
- Comply with the operating instructions.

1.9 Intended use

The piston pump is intended exclusively for conveying fluid product.

The piston pump is intended for commercial use only.

The pumped product must be compatible with the materials of the piston pump. The owner of the pump is responsible for selecting the pumped product.

The piston pump must only be used within the capacity limits listed in section 3 "technical data".

Any other use or use that extends beyond the specified intended use is considered as non-intended use. **SAMES KREMLIN** and the manufacture are not liable for damages resulting from non-intended use.

Intended use also includes:

- Observing all notes and instructions in the operating manual and all accompanying documents.
- Complying with prescribed intervals specified in the operating manual and its accompanying documents for inspections and maintenance operations.
- Assurance by the owner that the pressures permissible for the pump will not be exceeded in operation (this can occur, for example, by sudden closing of valves or pressure surges).

1.9.1 Additional information concerning the intended use of the incomplete machine in accordance with machinery directive 2006/42/ec

Motor and gearbox are not included in the scope of delivery. Risks arising from combining the piston pump with motor and gearbox, must be assessed and safeguarded against by the manufacturer of the overall system. The manufacturer of the overall system must ensure the safety of interfaces to the owner's machines and protection against hazards arising from installation in a system.

The control system is not included in the scope of delivery. The manufacturer of the overall system is responsible for designing the control system. The manufacturer of the overall system must integrate the incomplete machine into the operating concept (operating modes, operator panels) and safety concept (emergency stop circuits, access control) of the overall system.

The manufacturer of the overall system or the owner must:

- Earth the assembly (piston pump, motor and gearbox).
- Ensure that the conveyed product does not introduce impurities or solids into the machine (e.g. By installing filters).
- Suitable safety devices must be installed in the product circuit to protect the pump from overload. This can be done through a pressure-relief valve, for instance.
- Implement devices for monitoring pressure and fill level.
- If necessary, implement devices for monitoring the operating parameters of the piston pump.

The incomplete machine must only be operated in an overall system with valid CE mark.

1.9.2 Additional instructions on the intended use of the device in accordance with ATEX Directive 2014/34/EU

The device is designed for an intended use in potentially explosive atmospheres (Zone 1) (see section 3.3 "ATEX mark in accordance with Directive RL 2014/34/EU").

Motor and gearbox are not included in the scope of delivery. To use the piston pump as intended as part of an assembly in a potentially explosive atmosphere, the manufacturer must

- Combine the piston pump with devices that are conformant with directive 2014/34/eu and which, relative to the parameters, permit an intended use of the device.
- Properly mount and install the sub-devices of the assembly in accordance with the manufacturer's instructions.
- Prepare a risk assessment of the additional ignition hazards and other relevant hazards that arise through the assembly of the sub-devices. It must be ensured through the installation and assembly, that the explosion characteristics of the sub-devices have not been changed with respect to fundamental health and safety requirements. If, as result of the assembly, an additional ignition hazard is present, the assembly must be subjected to the entire conformity assessment procedure in accordance with directive 2014/34/eu, that is suitable for the category.

Detailed instructions concerning the procedure in reference to an assembly are provided in the atex guidelines (atex 2014/34/eu guidelines, april 2016) in § 44 "combined equipment (assemblies)".

1.9.3 Additional instructions for pumping product of average conductivity

The following always applies: liquid flows with low conductivity (<10000 ps/m) can generate very high charge densities. Therefore, the conductivity of the conveyed product should not be less than 10000 ps/m. For liquids of average conductivity (50 ps/m - 10000 ps/m), the following additional measures of explosion protection may be required:

- Ensure continuous filling of the pump with product during operation. Running the pump empty and the resulting pumping of explosive gases must be prevented.
 - When filling and emptying the pump, the pump speed must be reduced to a minimum.
-

1.10 Misuse

In particular, misuse includes:

- Pumping product that does not meet the product specification.
- Using the piston pump for other purposes.
- Operating a damaged piston pump.
- Operating the piston pump with bypassed safety devices.
- Operating the piston pump with an incomplete protective device.
- Operating the piston pump with modified parameters of the monitoring devices.
- Operating the piston pump with defective signalling and monitoring devices.
- Acknowledging safety devices while a person is still in the protected area.
- Operation, maintenance, and repair of the system by unauthorized and/or untrained personnel.
- Operating the piston pump outdoors.
- Operating the piston pump without earth.
- Using non-original spare parts.
- Operating the piston pump outside the specified parameters / operating data.
- Operating the piston pump at a location that is not free of vibration.
- Operating the piston pump at a location where ignition hazards are present due to sources of ignition in the vicinity of the piston pump.
- Use or commissioning of the piston pump by private users.
- Modification or conversion of the pump.
- Installation on unsuitable substrates.
- Attaching transport aids on the housing.
- Failure to comply with maintenance intervals.
- Operating the piston pump in potentially explosive gas atmospheres of zone 0.
- Operating the piston pump in explosive dust atmospheres.
- Faulty electrical installation (selection of cables and wires, as well as their connectors, earthing, etc.) By the manufacturer of the overall system or the owner.
- Combination with unsuitable devices (motor, gearbox, coupling).
- Replacing ex-protected sub-devices as defined in directive 2014/34/eu with non-compliant devices or those that are unsuitable for the application conditions.

- Immersing the piston pump in the conveyed product.
 - Operation in potentially explosive atmospheres without prior implementation of the requirements arising from directive 1999/92/ec and national regulations for explosion protection by the owner.
 - Initial commissioning without prior inspection of the area and the piston pump by a person qualified to conduct the inspection (for definition of "person qualified to conduct the inspection", see the german ordinance on industrial safety and health).
 - Pumping product that are chemically incompatible with the materials used to build the piston pump. The owner of the piston pump must test the chemical compatibility of the conveyed product.
 - Pumping of liquids with temperatures above 65 c.
 - Pumping contaminated product. The owner must ensure that the pumped product does not contain any impurities or solids (e.g. By installing filters).
 - Operation without monitoring pressure and filling level. Overpressure, insufficient supply, excessive resistance, dry-run beyond start-up, or exceeding the product vapour pressure, must be reliably prevented.
 - Pumping of product with parameters (e.g. Ignition temperatures) that are not compatible with the information on the marking of the device.
 - Pumping liquids with low conductivity (<10000 ps/m), as long as no additional safety measures have been taken.
 - Operation at a speed greater than is specified in section 3.1 and exceeding the permissible relative contact speeds between the moving parts of the piston pump of 1 m/s.
 - Use of unsuitable lubricants.
-

1.11 Warranty claims and liability

Our "General Terms and Conditions of Sale and Delivery" always apply. Our "General Terms and Conditions of Sale and Delivery" have been available to the owner of the Machine at the latest since the contract was entered into.

Warranty and liability claims for injuries or material damage are excluded, if they can be attributed to one or more of the causes listed below:

- Non-intended use.
 - Improper installation, commissioning, operation, and maintenance.
 - Operating the Machine with safety devices that are defective or with safety devices and protective devices that are not attached properly or not functional.
 - Ignoring the instructions in the Installation and Operating Manual regarding transport, storage, installation, commissioning, operation, maintenance, and set-up.
 - Unauthorised modifications.
 - Insufficient monitoring of Machine components subject to wear.
 - Improperly executed repairs.
 - Vandalism
 - Catastrophic events caused by the impact of foreign objects or force majeure.
-

2 Safety notices

2.1 Safety symbols in this Installation and Operating Manual



"DANGER" indicates an imminent danger that will result in severe or fatal bodily injury.



"WARNING" indicates a potentially dangerous situation that can result in severe or fatal bodily injury.



"CAUTION" indicates a potentially dangerous situation that can result in minor injuries.

Note "Note" indicates a potentially dangerous situation that can result in material damage or environmental damage.

This signal word is also used for application instructions and other useful information.

2.2 General safety notices

Danger for personnel and the machine



- Comply with all safety and hazard notices on the Machine and keep safety and hazard notices in a complete and legible condition.
 - Comply with all general and special safety notices in this Installation and Operating Manual and the operating manuals of third-party manufacturers.
 - Refrain from any unsafe working method.
 - Keep the Installation and Operating Manual on hand at all times.
 - Shut down the Machine immediately and notify the responsible department or person, if safety-relevant modifications have been made or the operational behaviour of the Machine changes.
 - Shut down the Machine immediately and notify the responsible department or person, if safety devices are damaged, defective or have been modified.
 - Comply with the relevant rules issued by the employers' liability insurance association for health and safety at the workplace (BG-Rules).
 - Do not remove or modify safety devices and warning signs on the Machine.
 - Do not modify Machine parts without authorization.
 - Do not modify the control devices and switching devices on the Machine.
 - Unauthorized persons are not allowed enter the workstations on the Machine.
-

Danger due to pumping of flammable fluids and operating the Piston Pump in potentially explosive atmospheres

- The Piston Pump may be used in potentially explosive atmospheres only if this is indicated on the rating plate of the assembly.
- Risks arising from combining the Piston Pump with motor and gearbox and possibly coupling, must be analysed and safeguarded against by the manufacturer of the assembly.
- The entity that executes the combination, i.e. assembly, must prepare an assessment of the ignition hazard, to ensure that explosion characteristics of products have not been changed with respect to fundamental health and safety requirements due to the installation and assembly. If additional ignition hazards arise through the assembly of the sub-devices, the manufacturer of the assembly must execute a conformity assessment procedure in accordance with Directive 2014/34/EU. (See section 1.9.2 "Additional instructions on the intended use of the device in accordance with ATEX Directive 2014/34/EU").
- The manufacturer or owner of the overall system must ensure the safety of interfaces to the owner's machines and the protection against hazards arising from installation in a system.
- The control system is not included in the scope of delivery. The manufacturer of the overall system is responsible for designing the control system.
- The owner of the Machine must apply Directive 1999/92/EC and national regulations on explosion protection.
- Ensure that the product hoses and other components can withstand the liquid pressure generated by the Machine.

Danger risk of explosion due to pump damage

- The owner must use filters to ensure that no solids enter the Piston Pump through the product.
 - The owner must check the chemical compatibility of the conveyed product with the materials used to build the Machine.
 - Do not subject the Machine to major mechanical forces.
 - Ensure that the exit point of the conveyed product is not clogged or closed.
 - Ensure that the maximum rotation speed is not exceeded.
-

Danger Explosion and fire hazard if there are leaks



- Comply with the safety data sheets provided by the manufacturer of the flammable liquids.



- Fire, naked light and smoking are prohibited.



- Keep ignition sources away.



- Avoid contact with skin and clothing. Take off soaked clothing immediately and do not put it back on until after it has been cleaned.

- In the event of damage to fluid-conveying components, turn off the machine and notify the responsible department or person immediately.

- Do not start up a damaged or leaking Machine.

- Properly dispose of any escaping liquids immediately.

- Have suitable extinguishing agents ready (see information in the safety data sheets of the manufacturers).

Danger risk of explosion in the potentially explosive atmosphere



- Comply with the safety data sheets for the pumped product.

- Careful handling of highly flammable product.

- Comply with the operating instructions issued by the owner.



- Fire, naked light and smoking are prohibited in potentially explosive atmospheres.

- Keep ignition sources away.



- In the entire potentially explosive atmosphere, activities are prohibited that can result in heating, electrostatic charging, electrical or mechanical sparks or development of fire.
-

Danger risk of explosion due to static discharge



- Connect the machine to a protective earth system (equipotential bonding) before initial commissioning.
- Operation of the machine without earth (equipotential bonding) and equipotential bonding between individual components through conductive connections is prohibited.
- Floors in potentially explosive atmospheres where people are present must be designed in such a manner that people do not become dangerously charged when wearing conductive footwear.
- Comply with the operating instructions issued by the owner.
- Do not wear metallic objects, such as watches or jewellery that may pose a hazard of electrostatic discharge.
- Wear ESD safety footwear.

Warning danger due to contact with harmful product

Danger due to breathing air contaminated with hazardous substances



The pumped product may be hazardous to health.

- Comply with the safety data sheets of the manufacturers.
- Comply with national laws, regulations, and ordinances on limit values.
- Use the prescribed protective equipment.

Warning risk of injury due to unavailability of protective equipment



- Wear the protective equipment specified by the company for all tasks on the Machine.
- Wear personal protective clothing.
- Comply with the information in the safety data sheets concerning the pumped product.
- Wear ESD-compliant clothing.
- Wear ESD safety footwear.

2.3 Safety instructions for transport, installation and initial commissioning

Dangers due to damaged components or assemblies



- Comply with statutory regulations for securing loads.
- The pallet must be larger than the goods.
- Properly lash the goods on the pallet.



- Only use hoists and load-handling equipment with sufficient load capacity for loading tasks.
 - Check all parts and components for damage after installation of the Machine.
 - Document any damage that is determined.
 - Check the Machine for damage before initial commissioning.
 - Report any transport damage to the carrier and the manufacturer immediately after receipt of the delivery.
 - Do not place a damaged Machine in service.
-

Danger risk of explosion due to improper installation and initial commissioning



- During assembly and disassembly, during transport to and from the place of use, and during the initial start-up, there is the risk involved of generating sparks, e.g. through friction, impact or grinding processes or through electrostatic charging. Consequently, ensure that these hazards are safely eliminated or that an explosive atmosphere is not present.
- Only have a specialist with explosion protection expertise perform electrical installations; electrical installations must be executed in accordance with the circuit diagram.
- Connect the Machine to a protective earth system (potential equalisation) before initial commissioning.
- Wear personal protective equipment (PPE).
- Rinse the Machine thoroughly with suitable product before initial commissioning to remove any paint-wetting disruptive substances introduced during the delivery process (goods receipt, handling, storage, assembly, etc.), substances incompatible with the conveyed product or foreign bodies causing mechanical damage from the inside of the Machine.
- Remove tools and other objects from the Machine.
- Ensure that the system components are properly supported to avoid weight load of the pump parts.
- Do not use the Machine as a support for the piping system.
- Ensure before initial commissioning that no electric or non-electric ignition hazards are present due to sub-devices of the Machine or ignition sources near the Machine.

Warning danger for personnel when transporting the Piston Pump



- Only assign qualified personnel to perform transport tasks.
 - Ensure that no one is in the danger zone.
 - Wear personal protective equipment.
 - Always take up the load symmetrically.
 - Maintain a safe distance from loads before they are lifted or lowered.
 - Do not stand under the lifted load.
 - The operator of lifting gear and transport equipment must keep the load and the danger zone in view at all times.
-

2.4 Safety notices for operation

Danger for personnel



- Ensure that the danger zone is clear of personnel before switching on the Machine.



- Be careful and alert in the entire work area of the Machine.
- Do not touch the Machine with sharp-edged or pointed objects or strike other objects.

Warning Improper machine operation



- Only qualified personnel with authorization for operation are allowed to operate the Machine.
- Familiarize yourself with the Machine.
- Clearly define responsibilities and work areas.
- Know the possible hazards on the Machine.

Warning improper operation of the Machine



- Use the Machine as intended.
- Check the Machine for damage before starting works.
- Use the Machine in a technically faultless, operational and functionally safe condition.
- Have the Machine repaired properly before placing the Machine in service.

Warning risk of injury if fluid-conveying parts of the Machine are damaged

Product escaping under high pressure develop unexpectedly high forces and can cause severe injuries.



- If fluid-conveying parts are damaged, switch off the Machine and notify the responsible department or person immediately.
- Only authorized specialists are allowed to perform tasks on fluid-conveying parts of the Machine.
- Seek immediate medical attention for injuries caused by fluids escaping under high pressure. The most severe infections or bodily reactions can be the result, if medical help is not provided immediately.

2.5 Safety instructions concerning set-up tasks, service, maintenance and troubleshooting

Danger risk of injury due to unexpected restart



- Switch off the machine and secure it against unintentional restart for set-up and service tasks, for maintenance and fault rectification.

Danger for personnel and the machine



- Only qualified personnel are allowed to set up and maintain the machine or rectify faults.
 - Comply with the safety notices in this installation and operating manual and in the operating manuals of third -party manufacturers before carrying out maintenance and repair tasks.
 - Familiarize yourself with the specific maintenance and repair instructions before carrying out the tasks.
 - Cordon off the area ensuring ample space required for set-up and service tasks, maintenance and troubleshooting.
 - Use the utmost caution when executing set-up and troubleshooting tasks, for which safety devices must be rendered inoperable and/or cover elements must be removed. Clearly define responsibilities and work areas.
 - Reattach all removed safety devices and / or cover elements immediately after concluding the tasks.
 - After concluding the tasks, ensure that no one is in the danger zone, before switching on the Machine.
 - Be careful and alert in the entire work area of the Machine.
-

Risk of explosion due to improper work

- Execute tasks only when the equipment is de-pressurised and de-energised.
- Comply with operating instructions and procedures of the owner, for example, procedures such as permits for working with sources of ignition in areas with a potentially explosive atmosphere.
- Comply with the safety instructions in this Installation and Operating Manual and in the operating manuals of third-party manufacturers before carrying out maintenance and repair tasks.
- Familiarise yourself with the specific maintenance and repair instructions before carrying out the tasks.
- Check the earth cable regularly for damage.
- Check the Machine regularly for damage or leaks.
- Comply with and implement maintenance intervals.
- Only qualified personnel are allowed to carry out repairs.
- Use only original spare parts.
- Remove all tools and objects from the interior and exterior of the Machine after setting up, maintenance, repair, service and troubleshooting tasks.
- An electrician must carry out all tasks on the electrical equipment of the Machine as well as the installation, commissioning, maintenance and repair in accordance with the circuit diagram and with particular consideration of the applicable regulations for potentially explosive atmospheres.
- Check all pipes, hoses and threaded fittings regularly for leaks and visible signs of damage. Rectify damage immediately.
- If the conductive cover is removed, the pump loses its contact with earth. To prevent electrostatic charges, ESD safety footwear must be worn in the potentially explosive atmosphere and the cover must be placed only on the conductive floor.

Danger: Damage to the Piston Pump and flammable liquids escaping due to incorrect torque applied to the housing screws

The prescribed tightening torque for the cylinder screws of the housing cover is 60 Nm. To prevent damage to and leaks of the Piston Pump, do not exceed this value.



- Tighten the cylinder screw of the housing cover with 60 Nm.
- Use a calibrated torque spanner.

Warning risk of injury when working on fluid-conveying parts of the Machine

Product escaping under high pressure develop unexpectedly high forces and can cause severe injuries.



- Switch off the Machine and secure it against unintentional restart for set-up and service tasks, for maintenance and fault rectification.
- Depressurise fluid-conveying parts before performing tasks.
- Only authorised specialists are allowed to work on fluid-conveying parts of the Machine.
- Use appropriate tools to detect leaks, do not use your hands.
- Check all pipes, hoses and threaded fittings regularly for leaks and visible signs of damage.
- After completion of all tasks on fluid-conveying parts, check fluid-conveying parts for proper seat and tightness, before each start-up, as specified in the maintenance schedule. Retighten if necessary.
- Rectify damage immediately.
- Lay out and mount fluid-conveying parts properly.
- Avoid skin contact. Wear personal protective equipment.

Seek immediate medical attention for injuries caused by fluids escaping under high pressure. The most severe infections or bodily reactions can be the result, if medical help is not provided immediately.

Warning risk of crushing and entanglement on moving parts

- Switch off the Machine and secure it against unintentional restart for set-up and service tasks, for maintenance and fault rectification.
- Execute tasks, for which safety devices must be rendered inoperable and/or cover elements must be removed, with the utmost caution. Refrain from any unsafe working method.
- Ensure that no one is in the danger zone and, in particular, within range of rotating or moving parts, before activating the Machine.
- Do not reach into rotating or moving Machine elements or devices.
- Always wear tight-fitting clothing.
- Tie back or cover long hair.
- Do not wear jewellery.

Note environmental pollution

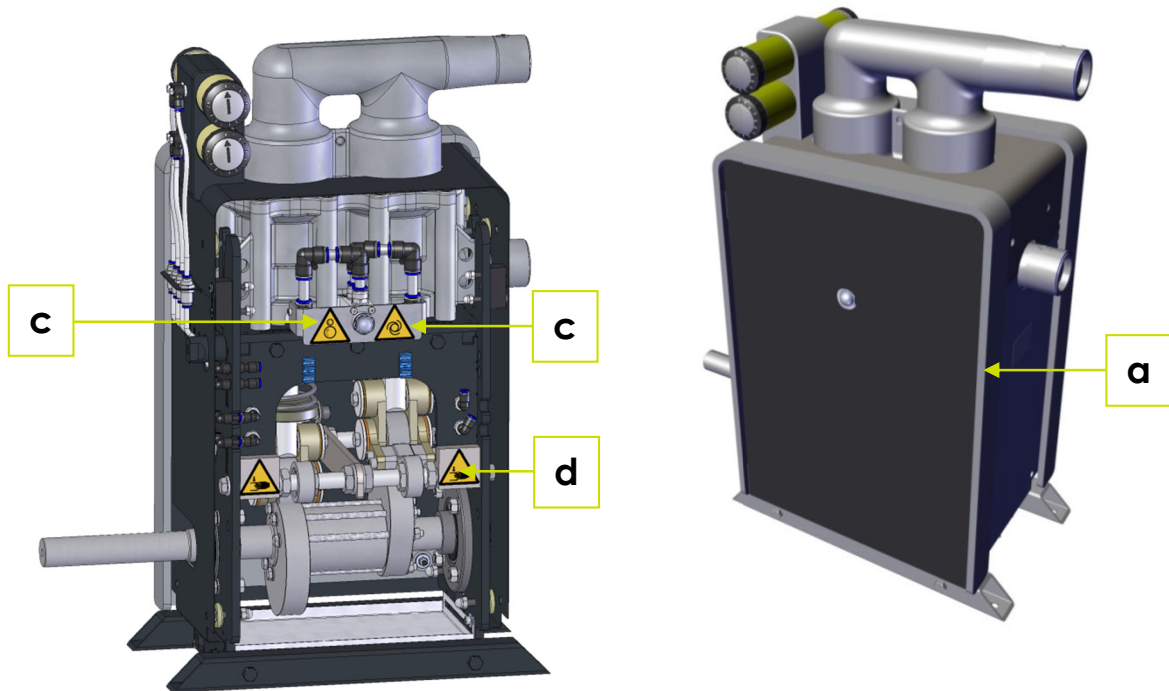

- Dispose of operating materials and auxiliary materials in a manner that is safe and eco-friendly.
 - Comply with the manufacturer's information.
-

2.6 Pump marking



a. Rating plate: electrical piston pump

Visible warnings (both sides), after removing the side parts.

- b.  Warning – counter-rotating rollers.
- c.  Warning – automatic start-up.
- d.  Warning – hand injuries

3 Technical data

3.1 Overall system

Machine designation	Piston Pump 30 l	Piston Pump 60 l
Item no.:	151700530	151700540
Distributor Type:	PaintCare ePCS-40 or 60 w/o motor	PaintCare ePCS-40 or 60 w/o motor
Manufacture Type:	KPE 1030	KPE 1040
Sound power level (LWA):	< 80 dB(A)	
Sound pressure level (LPA):	< 70 dB(A)	
Ambient temperatures:	+5 to +35 °C at maximum 80% relative humidity	
Maximum permissible delivery capacity:	30 l/min	60 l/min
Connections for fluids:	1 1/2" thread (special designs on request)	
Maximum suction head, dry:	6 m (H ₂ O; 20°C)	
Maximum inlet pressure:	1 bar	
Maximum permissible outlet pressure	20 bar	
Total weight:	approx. 120 kg	
Dimensions (W x D x H):	604 mm x 300 mm x 763 mm	
Stroke length of delivery piston:	50 mm	
Maximum permissible pump speed:	41.9 rpm At the permissible speed, the maximum permissible delivery capacity of 30 l/min and the permissible relative contact speed of 1 m/s between moving parts of the mechanical piston pump, are maintained.	78.2 rpm At the permissible speed, the maximum permissible delivery capacity of 60 l/min and the permissible relative contact speed of 1 m/s between moving parts of the mechanical piston pump, are maintained.

3.2 Product

Maximum viscosity of the pumped product:	approx. 15,000 mPa/s (depending on the application)
Temperature of the pumped product:	+5 ... +65 °C
Conductivity of flammable liquids:	> 10000 pS/m, if additional safety measures are taken, it is possible to convey product with lower conductivity.

3.2.1 Material of the parts in contact with the product

Cylinder block:	Stainless steel
Cylinder housing:	Stainless steel
Piston rod:	Chrome-plated steel
Piston:	Stainless steel with ceramic coating
Piston seal:	Polyethylene (PE)
Bellows:	PTFE
Ball valve:	Stainless steel
O-rings:	FEPM or NBR
Seal scraper ring:	PU

3.3 ATEX marking in accordance with Directive 2014/34/EU for the pump

CE  **II 2G Ex h IIB Gb T4 X**

Symbol	Meaning
CE	CE mark.
	Marking for prevention of explosions in accordance with ATEX.
II	ATEX device of device category II intended for use in potentially explosive areas, except for mines.
2 G	ATEX device of device category 2 (avoidance of effective sources of ignition in case of anticipated faults). The assembly may be used as intended in Zone 1 and Zone 2 explosive gas atmospheres. Using the device in areas subject to explosive dust hazards or in Zone 0 is not allowed.
h	Marking non-electrical devices for use in potentially explosive atmospheres.
IIB	Liquids of explosion groups IIA and IIB may be pumped. Pumping liquids of explosion group IIC is not permitted. The intended use is permitted in explosive gas atmospheres with gases and vapours of explosion groups IIA and IIB. The intended use is not permitted in explosive gas atmospheres with gases and vapours of explosion groups IIC.
Gb	Device protection class for gas. The device ensures the required degree of safety and avoidance of ignition sources in normal operation and for faults that can usually be expected (defects on the device).
T4	Maximum permissible surface temperature 135 °C.
X	Comply with the special operating conditions when using the device. See section 1.9 "Intended use" and in particular section 1.9.2 "Additional instructions on the intended use of the device in accordance with ATEX Directive 2014/34/EU", as well as the limits of the pump in section 3 Technical data

3.4 Identified ignition risks and protective measures

Possible potential ignition sources are hot surfaces, mechanically generated sparks, electrical compensation currents, exothermic reactions and static electricity.

Ignition sources from mechanically generated sparks and hot surfaces are avoided by restricting the relative speeds of individual components, use of suitable materials, lubrication of tribological pairs, restricting the surface size, and compliance with the intended use and organizational measures.

Ignition sources from static electricity and electrical compensation currents are avoided by restricting the relative speeds of the individual components, use of suitable materials, restricting the surface, integration into the local equipotential bonding, and compliance with the intended use and organizational measures.

Ignition sources from exothermic reactions and electrical compensation currents are prevented by the use of suitable materials and compliance with the intended use and organizational measures.

The ignition hazards of sub-devices from external suppliers are cited in the respective operating manuals.

3.5 Explosion-proof sub-devices

No.	Designation	Manufacturer	Type	Lubricant	Device identification
1	Lubricator	Klüber	Klübermatic FLEX	Klüberplex AG 11-461	II 1G Ex ia IIC T6 II 1G Ex iaD 20 T85°C I M1 Ex ia I

4 Structure and function

4.1 Piston Pump complete

The Piston Pump conveys fluid product.

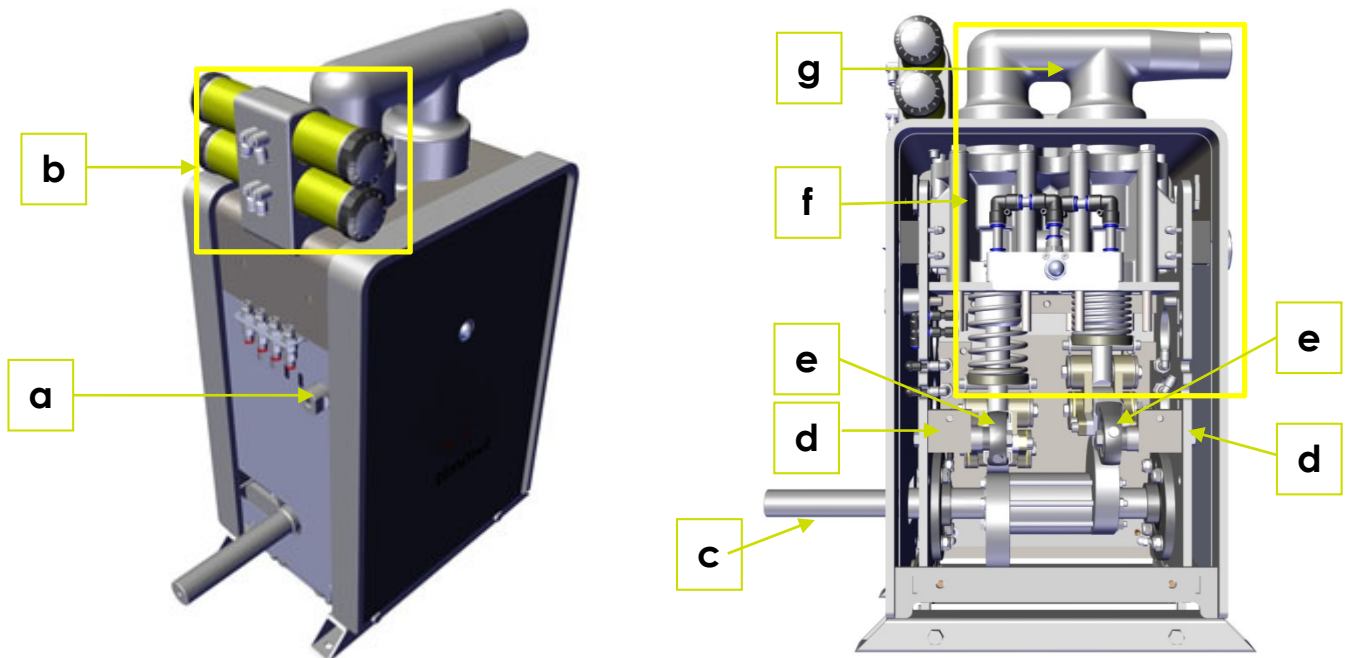

Figure 4-1 Piston Pump complete

Item	Designation	Function
a	Torque transducer	Secure torque support. The torque support for connecting the gearbox and pump unit is not included in the scope of delivery
b	Permanent lubricator	Supplies the bearings with lubricant
c	Drive train	Absorbs the rotary movement from the gearbox and drives the support rollers of the double-joint rockers
d	Bracket	Absorbs the forces from the double-joint rocker
e	Double-joint rockers with lubricating rocker	<p>Double-joint rocker: Drives the reciprocating piston and dissipates shear forces</p> <p>Lubricating rocker: Ensures uniform lubrication of the cam discs</p>
f	Pump head	Pumps product
g	Attachment point on the cylinder cover	Attachment point for load suspension devices

4.1.1 Drive train

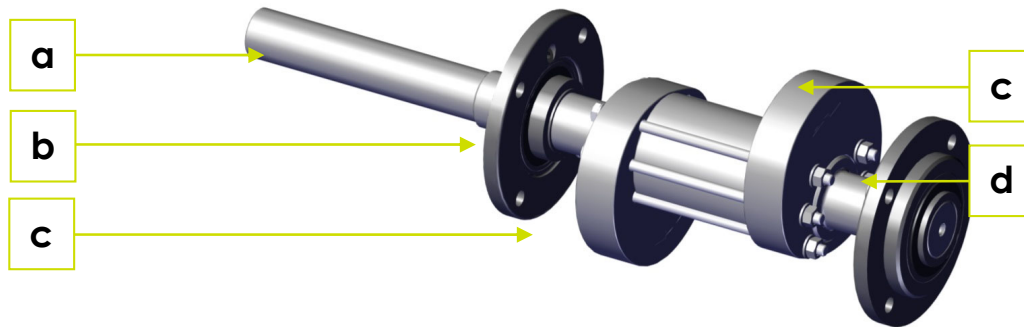

Figure 4-2 Drive train

Item	Designation	Function
a	Drive shaft	Absorbs the rotary movement of the gearbox
b	Adjustment bearing/tension bearing	Accommodates and guides the drive shaft
c	Cam plate	Drives the piston
d	Flange bearing	Accommodates and guides the drive shaft

4.1.2 Double-joint rocker with lubricating rocker

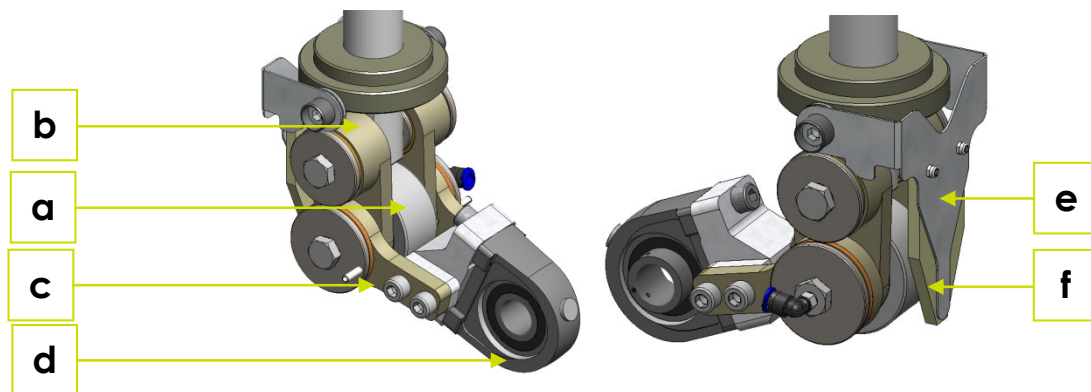

Figure 4-3 Double-joint rocker with lubricating rocker

Item	Designation	Function
a	Support roller	Drives the reciprocating piston
b	Joint plate with plain bearing bushing	Fastens the reciprocating piston
c	Lever with plain bearing bushing	Dissipates shear forces
d	Vertical bearing	Guides the movement of the support roller and transfers shear forces to the shear force axle
e	Holding plate	Holds and positions the lubricating felt
f	Lubricating felt	Take-up and uniform distribution of the lubricant on the support roller/cam plate

4.1.3 Pump head

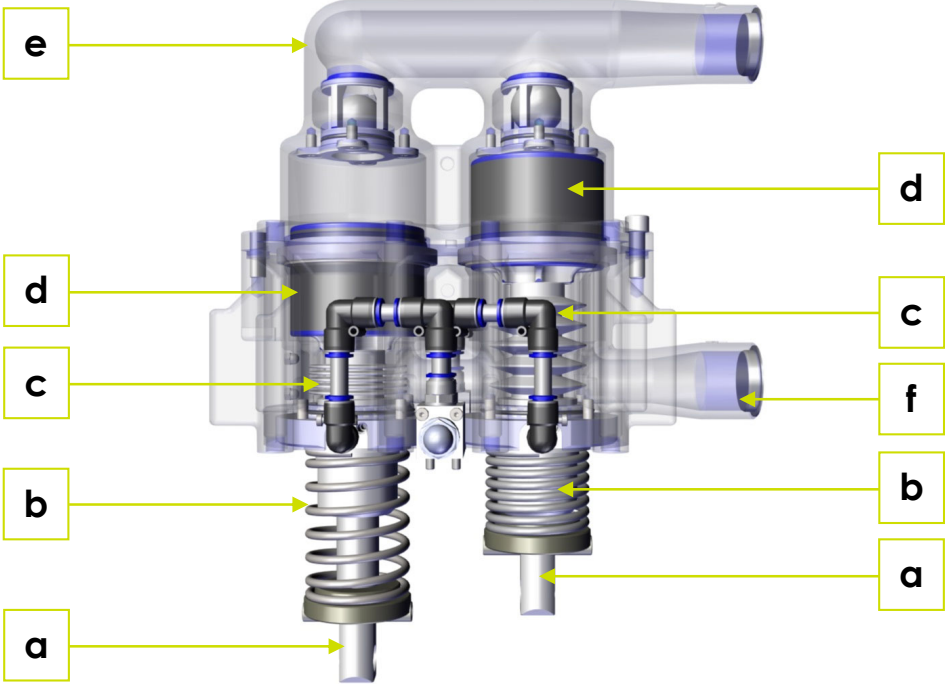

Figure 4-4 Pump head

Item	Designation	Function
a	Piston rod	Absorbs the movement of the support roller of the two-joint rocker
b	Compression spring	Supports the downward motion of the reciprocating piston
c	Bellows	Seals the piston rod
d	Reciprocating piston with ceramic coating	Suctions-in product (downward motion) and conveys it to the discharge (upward motion). The two reciprocating of the piston pump move in opposite directions.
e	Cylinder cover with drain	Accommodates the reciprocating pistons and transfers the pumped product forced out of the cylinder to the consumer.
f	Cylinder block with inlet	Allows pumped fluid into the pump head

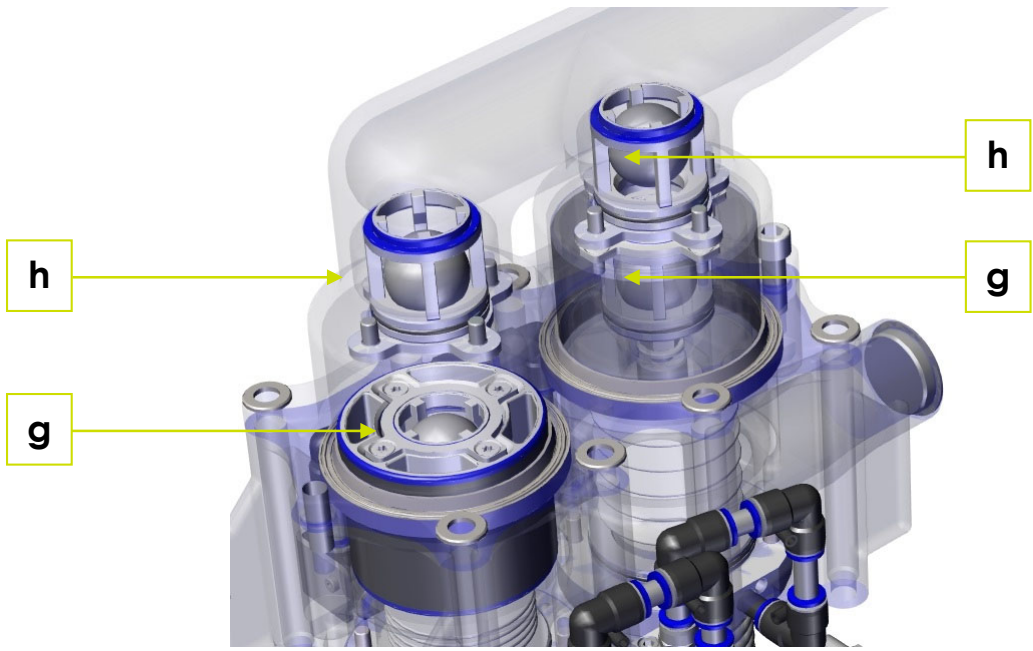

Figure 4-5 Pump head

Item	Designation	Function
g	Inlet valve	Opens the cylinder at downward motion of the reciprocating piston. Closes the cylinder at upward motion of the reciprocating piston.
h	Outlet valve	Closes the discharge port at downward motion of the reciprocating piston. Opens the discharge port at upward motion of the reciprocating piston.

4.2 Protective devices

4.2.1 Emergency stop devices

The machine is equipped with an emergency stop device.
 If necessary, the manufacturer of the complete system must integrate the machine into the emergency stop chain of the complete system. If necessary, emergency stop devices (such as emergency stop buttons) must be mounted in the area of the machine.

4.2.2 Protective cover

The rotating and moving parts of the Machine are safeguarded with protective cover. For operation of the Machine, the protective cover must be mounted.

When the protective cover is removed for maintenance purposes, the connection between cover and pump, and thus the connection to earth, is interrupted. Therefore, the powder coating of the protective cover is conductive. Due to the conductance of the protective cover, earthing occurs through a person or the floor to prevent electrostatic charging of the protective cover.

Access to the incomplete Machine must be controlled by the owner and secured by the manufacturer of the overall system.

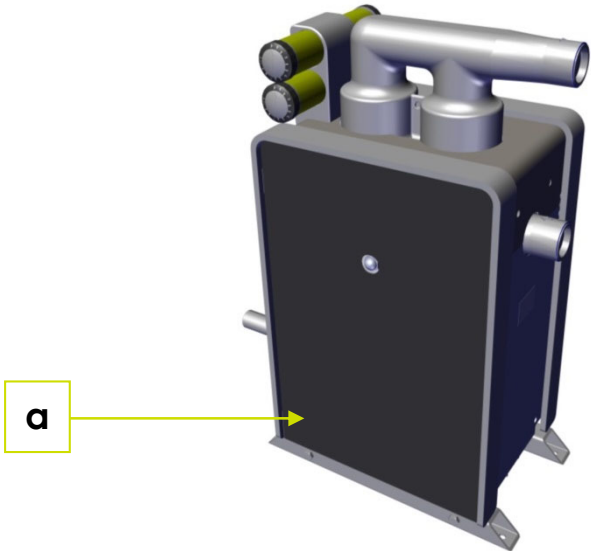

Figure 4-6 Protective cover

Item	Designation	Function
a	Protective cover	Prevents crushing and entanglement. Coating of the protective cover prevents electrostatic charging.

4.2.3 Seals

To prevent flammable fluids escaping from the cylinder block, the block is sealed with a bellows. A sight glass allows an indirect check to determine if one of the bellows is damaged. If a bellows is damaged, paint is visible in the sight glass (Fig. 4-7 item b) A seal scraper ring prevents flammable fluids from escaping out of the cylinder block when a bellows is damaged.

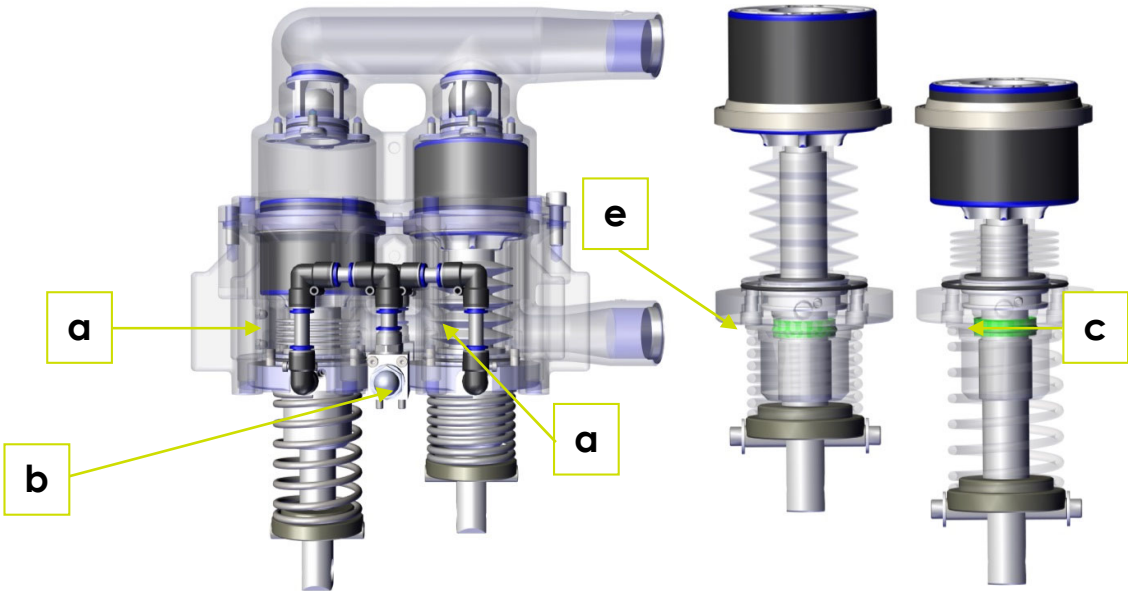

Figure 4-7 Seals

Item	Designation	Function
a	Bellows	Seals the piston rod
b	Inspection glass	Displaying leaks in the bellows. The air of the compressed bellows is pushed into the expanded bellows through the inspection glass. If a bellows is damaged, liquid is visible in the inspection glass.
c	Seal scraper ring	Seals the piston rod when a bellows is damaged.

5 Transport, assembly, installation and initial commissioning

5.1 Safety notices

Danger comply with the safety notices



- Comply with the safety notices in section 2 "Safety notices" and in particular in section 2.5 "Safety instructions concerning set-up tasks, service, maintenance and troubleshooting".

Warning danger for personnel when transporting the machine to its location



- Only assign qualified personnel to perform transport tasks.
- Secure the load properly for transport to the owner's site.
- The transport of the piston pump by crane is permitted only via the attachment point provided on the cylinder cover.
- always take up the load symmetrically.
- Transporting the load above personnel is prohibited.
- Do not stand under suspended loads.
- Maintain a safe distance from loads before they are lifted or lowered.
- Keep unauthorized persons away from the task area.
- Avoid abrupt crane movements.
- Ensure that the danger zone is clear of personnel before moving the load.
- The operator of lifting gear and transport equipment must keep the load and the danger zone in view at all times.
- Wear personal protective equipment.

Note to prevent damage, only transport the Piston Pump in its original packaging.

5.2 Unpacking the machine and checking the scope of delivery

Work steps:

1. Inspect the machine for apparent transport damage, scratches and similar damage.

Note take photographs of any damage and immediately report the damage to the manufacturer.

-
2. Remove the transport packaging from the Machine and dispose of it in accordance with local environmental regulations.

Note ensure that the machine is not scratched with a cutting tool (knife or scissors) when cutting open the packaging.

-
3. Examine the Machine for transport damage.

Note immediately report any discrepancies to the manufacturer.

-
4. Use the delivery note to verify the completeness of the delivery.
-

5.3 Installation of motor and gearbox

The device must be properly connected to a suitable motor and a suitable gearbox. Installation must be implemented in accordance with the information in the operating manuals for the motor and the gearbox. It may be necessary to attach additional protective covers to prevent access to moving parts.

For intended use of the incomplete machine or the ATEX device, section 1.9 "Intended use" must be complied with.

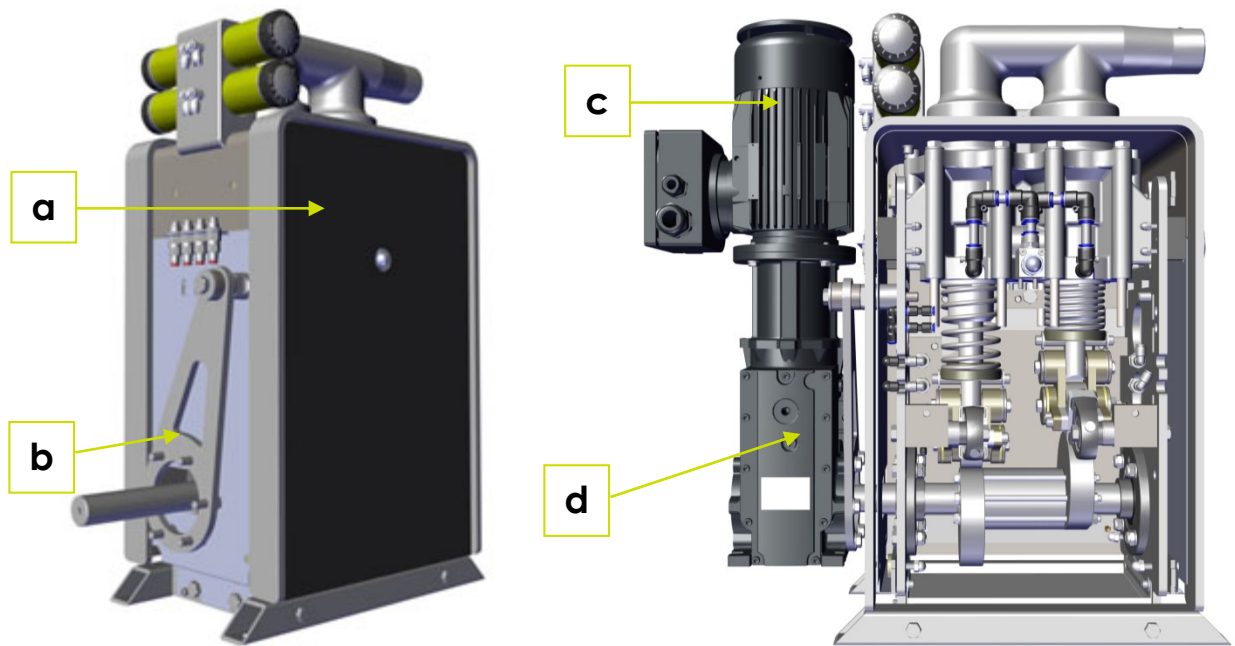
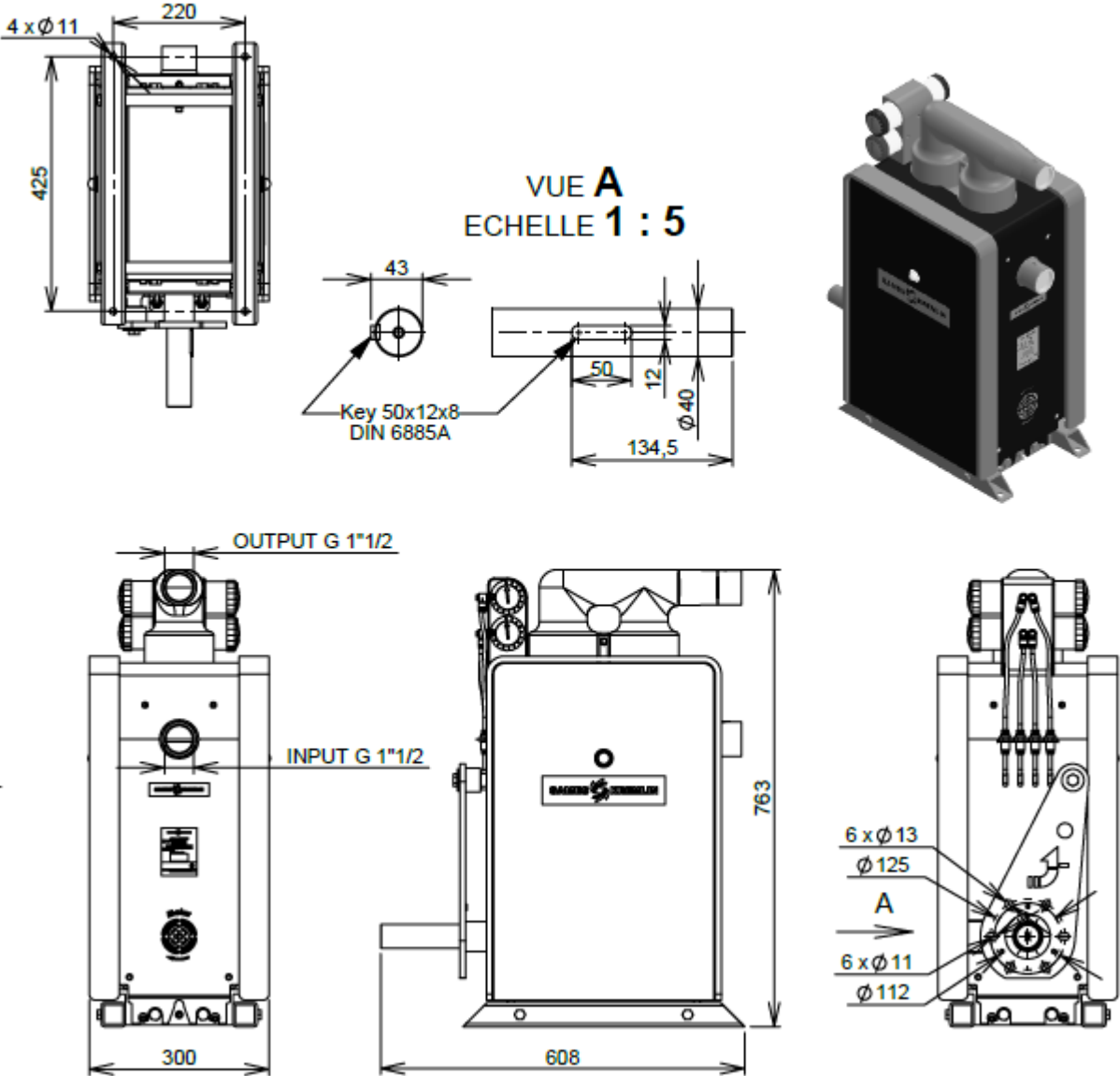

Fig. 5-1: Installation of motor and gearbox (example)

Item	Designation	Function
a	Piston Pump	Pumps the product.
b	Torque support	Connects gearbox to pump unit. The torque arm is not included in the scope of delivery.
c	Motor	Drives the gearbox. The motor is not included in the scope of delivery.
d	Gearbox	Drives the drive shaft. The gearbox is not included in the scope of delivery.

5.3.1 Mechanical connection PaintCare ePCS 40-60



5.3.2 Mechanical connection PaintCare ePCS 30

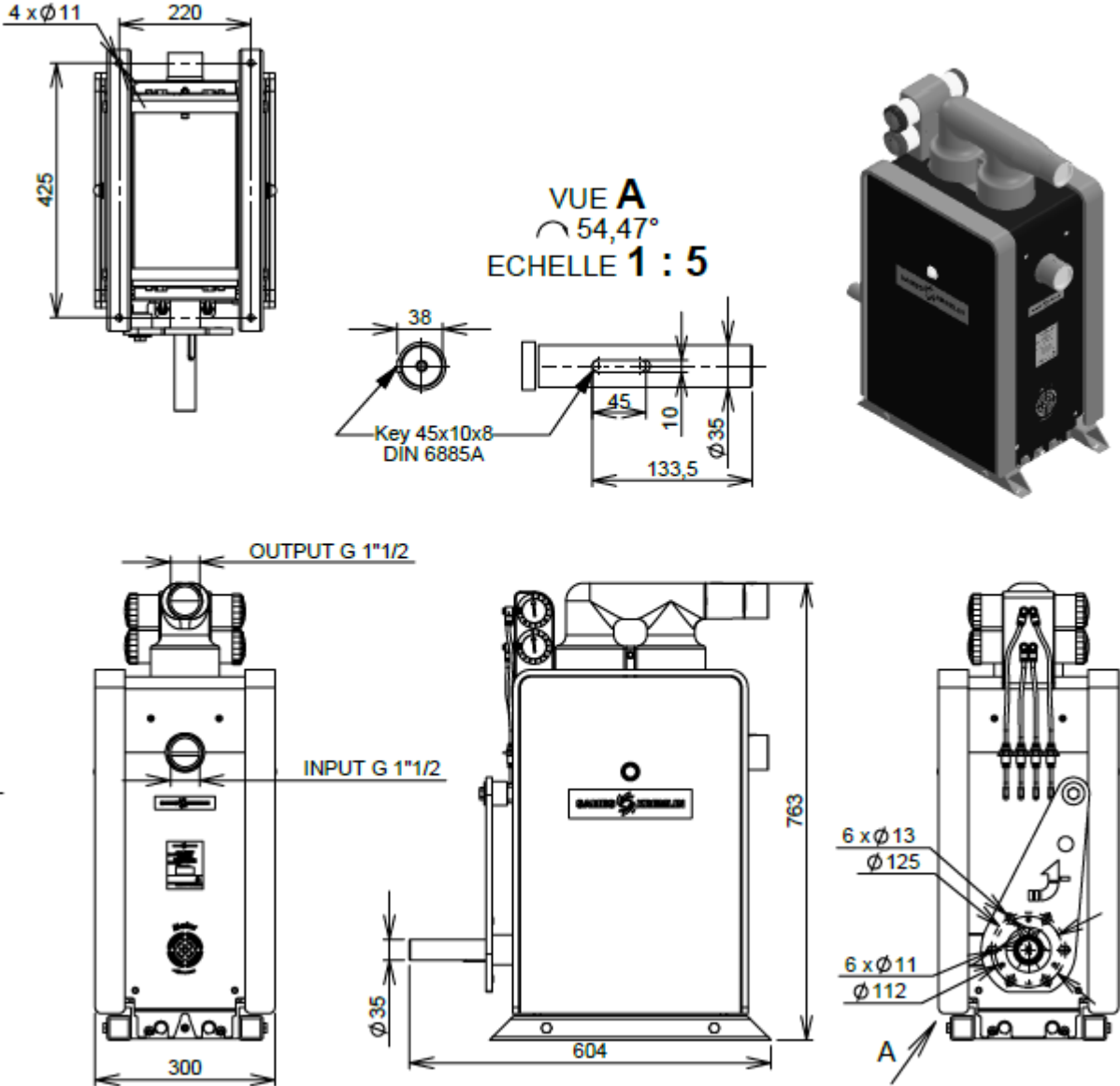

5.4 Installation, connection and initial commissioning

The installation instructions in the layouts and assembly drawings apply for installation of the Machine.

The load-bearing capacity of the floor must be designed for the Machine weight or for the weight of the assembly. The floor must be free of vibration and provide a solid substrate for the installation. Vibration must not be transmitted via the floor.

Authorised personnel by the manufacturer of the complete machine or qualified personnel authorised by the owner must install the Machine in accordance with the design drawings and dismantle the Machine upon expiry of its service life.

Qualified personnel of the manufacturer of the complete machine or the owner of the complete machine must connect the Machine to the electrical system and integrate the Machine into the control system.

Suitable safety devices must be installed in the product circuit to protect the pump from overload. This can be done through a pressure-relief valve, for instance.

Suitable sensors must be integrated in the product circuit to monitor the fill level and the pressure. In the case of excess pressure, or no-load operation the pump must be switched off.

Qualified personnel of the manufacturer of the overall machine or the owner of the overall machine must carry out the initial commissioning.

5.4.1 Installing, connecting and commissioning the machine

Danger due to improperly executed maintenance tasks



- Before installing the Machine, ensure that an explosive atmosphere is not present in the area.
- Only have a specialist with explosion protection expertise perform electrical installations; electrical installations must be executed in accordance with the circuit diagram.
- Connect the Piston Pump to a protective earth system (potential equalisation) before initial commissioning.
- Wear personal protective equipment (PPE).
- Prior to commissioning, purge the Piston Pump with suitable product to remove from the pump interior any substances introduced during the customer process (goods receipt, handling, storage, installation, etc.) that are detrimental to paint adhesion, or substances that are incompatible with the pumped product.
- Ensure that the system components are properly supported to avoid weight load of the pump parts.
- Do not use the Piston Pump as a support for the piping system.
- Ensure before initial commissioning that no electric or non-electric ignition hazards are present due to sub-devices of the Piston Pump or ignition sources near the Piston Pump.

Danger for personnel and the machine



- Only qualified personnel are allowed to install the machine.
- Do not immerse the pump into the product to be pumped.
- Ensure that the connectors are compatible with the product to be pumped and are able to withstand high pressures.
- Dimension the piping cross-sections sufficiently large. Cross-section size depends on the viscosity of the product and the conditions of the system.
- Use suitable hose clamps to attach intake hose and delivery hose.
- The direction of flow is indicated by arrows on the pump housing. Pay strict attention to these arrows; do not remove them, keep them in faultless, recognizable condition.

Note use flexible connections (e.g., hose connections) for intake and discharge. The flexible connections prevent transmission of vibration to the piping system.

Prerequisites for commissioning:

- The Piston Pump must have been thoroughly flushed with suitable agents to remove any foreign substances from the pump interior.
 - Piston Pump, motor and gearbox must be properly mounted.
 - There must not be an explosive atmosphere in the installation area.
 - If necessary, devices for filtering the pumped product must be present.
 - Devices for monitoring pressure and fill level must have been implemented.
 - Devices for monitoring the operating parameters of the piston pump and motor must have been implemented, if necessary.
-

Work steps:

1. Place the pump on a horizontal and smooth surface with the cylinder cover pointing upward.
2. Use suitable fastening bolts to fix the pump in place on the foot pipes (a) on the floor, to ensure a safe stance.

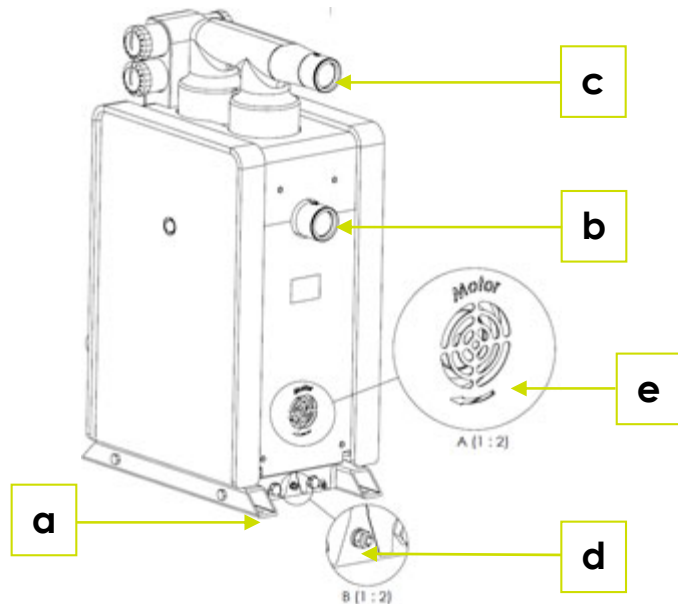

3. Connect intake line to the entry point (b) and supply.
4. Connect delivery line to the exit point (c) and consumer.
5. Properly incorporate the connection for equipotential bonding (d) into the local equipotential bonding by means of a PE conductor.
6. Properly connect the machine into the control system and electrical supply. When mounting and activating the drive, pay attention to the pump's direction of rotation. The direction of rotation of the connected motor must agree with the direction of rotation of the arrow (e) on the cover plate. At low speed, you can visually check the correct direction of rotation of the pump through the sight grille.
7. Check all connections for leak-tightness and firm seat.
8. Set the dispensing time to the maximum of 12 with the adjusting screws of the permanent lubricator, so that the quantity of grease is discharged within 12 months.
9. Ensure that there are no electrical ignition hazards or non-electrical ignition hazards due to sub-devices of the machine or due to ignition sources in the vicinity of the machine.
10. Carry out the initial commissioning in accordance with the operating manual provided by the manufacturer of the overall system.

6 Operation

The Machine is operated by the control system implemented by the manufacturer of the overall system. The manufacturer of the overall system must ensure that the pump functions are fully integrated into the control system. The manufacturer of the overall system must implement the following operating modes.

The Machine is operated in the following modes:

- Production (constant pressure)
 - Flow (constant flow rate)
-

6.1 Safety notices

Danger comply with the safety notices



- Comply with the safety notices in section 2 "Safety notices" and in particular in section 2.4 "Safety notices for operation".
-

6.2 Operating and control elements

Operating and control elements of the Machine are accommodated in the control system of the overall system.

The manufacturer of the overall system must integrate the Machine into the operating concept of the overall system.

6.3 Basic checks before and during operation

Familiarize yourself with the work environment before starting work. Inspect the Machine visually for defects at least once a day (visual inspection). Comply with the intervals for inspections and maintenance as specified in section 7 "Maintenance and care" before starting work.

Before switching on the Machine, take note of any irregularities in the area of the complete Machine. The following characteristics indicate irregularities when machine and control system are switched on:

- Increased noise level or irregular / unusual noises.
- Unusual odor.
- Smoke development.
- Stains of operating materials (oil, grease) on the Machine or on the ground.
- Performance drop during operation.
- Positions are not approached correctly.
- Pumped product escapes.

Bring the Machine to a standstill immediately if one of the characteristics cited above occurs. Immediately notify maintenance personnel to obtain a precise assessment of the technical status. Maintenance personnel must decide whether operation can be continued without further restriction of the functionality of the Machine. Initiate repair measures immediately if a failure can be anticipated due to the determined damage.

6.4 Operating the machine

The Machine is operated with the control system of the overall system. The Machine must be operated in accordance with the information in the operating manual for the overall system.

6.4.1 Switching on the machine

Prerequisites

- The machine must have been visually inspected. The machine must be in order (faults rectified).
- Safety devices must be in protective position (e.g., cover elements must be mounted).
- Check whether the permanent lubricator is in operation. If this is not the case, activate the permanent lubricator as described in 5.4.1.

Note: information concerning switch-on of the incomplete machine is provided in the operating manual for the overall system.

6.4.2 Machine operation

Prerequisites

- Machine must be switched on.

Note: information concerning operation of the incomplete machine, such as regulating the flow rate, is provided in the operating manual of the overall machine.

6.5 Switching off the machine

Prerequisites

- Machine must be switched on.

Note: information concerning switch-on of the incomplete machine is provided in the operating manual for the overall system.

7 Maintenance and care

To ensure trouble-free use of the Machine as intended, the care and maintenance tasks discussed in this chapter are required. Regular care and maintenance extend the service life and increase efficiency.

For safe operation of the Machine, the maintenance tasks must be carried out regularly and intervals must be complied with. Failure to comply can cause damage and an increased risk of accidents.

Use only the operating materials and auxiliary materials recommended by the manufacturer. Recommended lubricants are specified where required. Mixing of lubricants is categorically prohibited.

7.1 Safety notices

Danger comply with the safety notices



Comply with the safety notices in section 2 "Safety notices" and in particular in section 2.5 "Safety instructions concerning set-up tasks, service, maintenance and troubleshooting".

7.2 Maintenance table

Machine part	Tasks to be executed	Interval	
Piston Pump complete	Check for proper condition and cleanliness of the Machine	At each shift	
	Check for proper function	At each shift	
	Check and, if required, re-tighten all screws	Monthly	
	Remove dust from the housing	Monthly	
Electrical equipment	Check the electrical equipment. Replace any damaged cables or operating materials immediately.	Monthly	
Pump head	Flush the pump head	Depending on the pumped product, see section 7.4	
Bearings	Replace the permanent lubricator. The ignition temperature of the lubricant must be at least 50 K above the maximum surface temperature of the Piston Pump or the machine (EN 80079-37, Section 5.5). Only use lubricants approved by manufacture. The wrong lubricants can cause premature failure of the pump. A suitable lubricant is available from SAMES-KREMLIN . Comply with and implement the manufacturer instructions for installation of the permanent lubricator in a potentially explosive atmosphere.	Yearly or as specified by the manufacturer	
	Visual and acoustic inspection of the bearings	At each shift	
	Check the bearings for grease leaks and noise	Monthly	
	The bearings must be replaced when reaching the basic rating life, or suitability for further use must be verified by a monthly inspection. Increased bearing temperatures or excessive noise development are reliable indicators of bearing damage.		
	Calculated nominal service life (Lh10) in operating hours (oh)* for:		
	Pump type (Type series)	PTI-KPE 1030 VA	PTI-KPE 1060 VA
	Pump type distributor (item no.)	151700530	151700540
	Flange bearing unit	46000	15708
	Adjustment bearing/tension bearing	46000	29360
	Roller bearing support roller	28000	6816
Vertical bearing	46000	82973	
When replacing the bearings, we recommend replacing the lubricating rockers as well.			
Seals	Visual inspection via the sight glass to determine whether the bellows are in order.	At each shift	
	Check the seals and replace, if necessary	Every 6 months	
Grease tray	Check grease tray and empty it if necessary	Monthly	
Motor	Service the motor as specified by the manufacturer.	As specified by the manufacturer	
<p>Only trained qualified personnel or Timmer employees can replace the components listed above.</p> <p>*The service life has been determined for the following type of operation, for other types of operation the manufacturer must be contacted:</p> <p>Item no. PTI-KPE 1030 VA: 90% basic load (16 bar & 15 l/min) and 10% peak load (16 bar & 30 l/min).</p> <p>Item no. PTI-KPE 1060 VA: 90% basic load (20 bar & 23 l/min) and 10% peak load (20 bar & 40 l/min)</p> <p>Modes of operation at high speed, high working pressure and high operating temperature reduce the nominal service life.</p> <p>Modes of operation at lower speed, lower working pressure and lower operating temperature increase the nominal service life.</p>			

Only trained personnel can replace the components listed above.
SAMES KREMLIN overs the replacement by well-trained employees.

7.3 Flushing the pump

Note damage to the Piston Pump due to hardening, crystallising product

The Piston Pump must be cleaned before long periods of standstill, when pumping fluids that harden, crystallise, contain solids or corrode pump materials, due to their chemical or physical properties.

The definition of a long standstill period depends on the previously pumped product and its aggregate state change from liquid to solid.

The definition is the responsibility of the owner and should always be complied with to avoid Piston Pump damage.

Note clean the Piston Pump only with a suitable cleaning agent depending on the pump material and the pumped product.

Water or solvents could be suitable.

Liquid and solid cleaning agents must not exceed a temperature of 65 °C.

Work steps

1. Machine De-energise and depressurise.

Note information on switching off the Machine is provided in the operating manual of the overall system.

-
2. Connect the suction pipe connection to the cleaning agent.

3. Connect the product discharge to a suitable container.

Note information on switching off the Machine is provided in the operating manual of the overall system.

-
4. Switch on the Piston Pump and pump cleaning agent until all residues have been detached from the pump.

Note information on switching off the Machine is provided in the operating manual of the overall system.

-
5. Pull the suction hose out of the cleaning agent far enough that air is suctioned in.

6. Let the pump run until cleaning agent no longer escapes at the outlet.

-
7. Switch off the machine and prevent it from being switched on again unexpectedly.

Note information on switching off the Machine is provided in the operating manual of the overall system.

-
8. Disconnect the product outlet.

9. Disconnect the intake pipe.
-

8 Troubleshooting

8.1 Safety notices



Danger comply with the safety notices

Comply with the safety notices in section 2 "Safety notices" and in particular in section 2.5 "Safety instructions concerning set-up tasks, service, maintenance and troubleshooting".

8.2 Faults in the workflow

If there are faults in the workflow of the Machine, inform the maintenance department. Refer to the fault message shown on the display for troubleshooting and rectification.

For faults in the control system and/or the electrical system, consult with an electrician who can use the wiring diagrams to determine and rectify the problem.

8.3 Fault table

Note In the event of fault, bear in mind that the Piston Pump is part of an assembly and is integrated in the control system of an overall system. Therefore, faults on the Machine may be related to other sub-devices of the assembly and the control system of the overall system. These faults must be remedied in accordance with the instructions in the operating manuals for the other sub-devices of the assembly and the operating manual for the overall system.

Fault	Cause	Remedy
Pump does not run or it runs too slow	Energy supply interrupted	Check the cabling of the Machine
	Emergency stop button not unlocked	Eliminate the cause for the emergency stop and unlock the emergency stop button
	Fault in the Machine control system	Check the control system of the Machine
	Sensors contaminated or defective	Check and clean the sensors, replace if necessary
	Motor defective	Check the motor, replace it if necessary
	Gearbox defective	Check the gearbox, replace it if necessary
	The hose cross-section is too small	Use a hose with a larger cross-section
	Control valve leaks	Replace distributor valve and seals
	Seal swollen or piston material damaged	Check material resistance, avoid dry run
	Blocked by foreign object	Remove the foreign object
Pump runs but it fails to pump any product	Valves contaminated	Flush the pump with cleaning agent. Clean or replace the valves
	Delivery hose is clogged	Clean delivery hose
	Suction and pressure valves are contaminated	Let the pump run for 10 to 20 minutes at top speed
	Leaking connections; possible intake of external air; vacuum collapses	Check connections for leaks; re-seal
	No suction effect on the suction-side and pressure-side	Put your hand over the openings to feel the suction effect and, if necessary, replace the seals

Fault	Cause	Remedy
	Excessive viscosity of the pumped product	High-viscosity product cannot be pumped (see section "Technical data" for the limit values)
	Delivery hose has cracks or holes	Replace delivery hose
	Excessive counter-pressure at the injection point	Reduce counter-pressure at the injection point
	Threaded fittings, ball valve or non-return valve either have no passage or reduced passage	Restore passage: Clean or replace
	Air in the pump chamber	Vent the pump
Fluid tank runs empty autonomously	Exit point of the fluid is lower than the fluid level in the container	Place the fluid container lower or position the exit point higher
Unusual noises	Incipient bearing damage	Switch off the machine immediately and replace the bearings
	Moving or rotating Machine parts are worn	Switch off the machine immediately and replace the affected Machine parts
	Moving or rotating Machine parts are not adequately fastened	Switch off the machine immediately and fasten the Machine parts
Unusual odour	Machine Parts are too hot	Switch off the Machine immediately and allow it to cool down; determine and eliminate the cause
Leaks	Wear on seals	Replace seals

8.4 Repair

To maintain trouble-free operation of the Machine as intended, repairs may be necessary or cannot be avoided.

The use of original spare parts and wear parts, as well as authorised accessories ensures operational reliability of the Machine and protects personnel and the environment from unforeseeable hazards.

9 Storage, dismantling and disposal

9.1 Safety notices

Danger comply with the safety notices



Comply with the safety notices in section 2 "Safety notices" and in particular in section 2.5 "Safety instructions concerning set-up tasks, service, maintenance and troubleshooting".

Danger due to explosive atmosphere



- De-pressurise and de-energise the Machine before dismantling
- Keep ignition sources away
- Fire, naked light and smoking are prohibited
- Use only explosion-proof tools
- Clean Machine parts of any flammable residual liquids
- Dispose of flammable residual liquid and contaminated cleaning cloths properly

Warning risk of injury due to improperly executed dismantling tasks



- Only assign qualified personnel to dismantle the Machine
 - Keep unauthorised persons away from the task area
 - Use personal protective equipment
 - Use only faultless, suitable and adequately dimensioned lifting gear
 - Standing under suspended loads is prohibited
 - The operator of lifting gear and transport equipment must keep the load and the danger zone in view at all times
-

Warning risk of injury when working on fluid-conveying parts of the Machine

Product escaping under high pressure develop unexpectedly high forces and can cause severe injuries.



- Before dismantling the Piston Pump, review the safety data sheets of the previously pumped chemicals.
- Switch off the Machine and prevent it from being switched on again unexpectedly.
- De-pressurise the Piston Pump before dismantling. Under some circumstances there may still be a low residual pressure in the pressure chamber that causes product to spray out.
- Only authorised qualified personnel are allowed to work on fluid-conveying parts of the Machine.
- Avoid skin contact. Wear personal protective equipment.
- Seek immediate medical attention for injuries caused by fluids escaping under high pressure. The most severe infections or bodily reactions can be the result, if medical help is not provided immediately.

Note environmental pollution

- Dispose of all Machine parts properly in accordance with relevant local legislation.
- Dispose of operating materials in accordance with relevant local regulations.

9.2 Decommissioning and uninstalling

Ensure the following prior to uninstalling:

- De-pressurise and de-energise the Machine before uninstalling.
 - Switch off the grease discharge with the adjustment screws of the permanent lubricator before uninstalling.
 - Before uninstalling, check the dismantling area for possible sources of ignition and remove these sources.
-

9.3 Storage

Ensure the following prior to storage:

- Only store the Piston Pump after thorough cleaning.
- Switch off the grease discharge with the adjustment screws of the permanent lubricator before storing.
- Extreme storage conditions accelerate the ageing process and must be avoided.

Note we recommend a storage temperature between +10°C and +25°C.

9.4 Disposal

For disposal, dismantle the Machine properly and ensure that component parts are professionally recycled. Please send the pump to the following address:

SAMES KREMLIN SAS

13 Chemin de Malacher

38240 Meylan

France

Note Please send the Piston Pump in the original packaging to avoid transport damage.

The piston pump must be flushed and the surface must be cleaned.

Always include the safety data sheet of the last pumped product or cleaning agent with the returned device.

10 Appendix

10.1 Documentation of third-party manufacturers

Manufacturer	Designation
Klüber	Operating instructions Klübermatic FLEX

10.2 Spare parts list

Note use only original manufacture spare parts. Information concerning spare parts can be requested from **SAMES KREMLIN**. Only trained personnel are allowed to install spare parts.

10.3 EC Declaration of Incorporation in accordance with EC Machinery Directive 2006/42/EC

EC Declaration of Incorporation

acc. to EU Machinery Directive 2006/42/EC, EU Gazette L 157/24 of 09 June 2006, Appendix II B

Declaration by the manufacturer: Timmer GmbH
Dieselstraße 37
48485 Neuenkirchen
Phone: +49 (0) 5973 9493-0

Manufacturer of the incomplete machinery:

General designation: Piston Pump
Function: Pumping of fluid product
Type series: PTI-KPE1030 & PTI-KPE1060
Item designation* PTI-KPE 1030 VA-XX-XX-XX (-XX)-SAM
PTI-KPE 1060 VA-XX-XX-XX (-XX)-SAM
Item designation distributor: PaintCare ePCS-30 w/o Motor
PaintCare ePCS-40 or 60 w/o Motor

Trade name: Mechanical Piston Pump

The following fundamental safety and health protection requirements in accordance with Annex I of the Machinery Directive 2006/42/EC have been applied and met:

Annex I, Articles 1.1.2, 1.1.3, 1.1.5, 1.3.1, 1.3.2, 1.3.3, 1.3.4, 1.3.7, 1.3.8.1, 1.4.1, 1.4.2.1, 1.5.7, 1.5.8, 1.7.2, 1.7.3, 1.7.4., 1.7.4.1 and 1.7.4.2

The specific technical documents in accordance with Annex VII Part B have been prepared.

The manufacturer undertakes to submit the specific documentation of the incomplete machine electronically upon request by the national authorities.

Person authorised to compile the technical documentation: Timmer GmbH, Dieselstraße 37, 48485 Neuenkirchen, Phone: +49 (0) 5973 9493-0

Commissioning is prohibited until it has been determined that – where applicable – the machine in which the aforementioned incomplete machine is to be installed complies with the specifications of Machinery Directive 2006/42/EC.

Neuenkirchen, 09/2021

City/date

Klaus Gehrman, Managing Director

*Places marked by an "X" in the type key are placeholders and can be replaced with the actual characters.

10.4 Declaration of Conformity in accordance with ATEX Directive 2014/34/EU

EU Declaration of Conformity

In accordance with EU ATEX Directive 2014/34/EU, OJEU L 96/309 of 26 February 2014, Annex X

The manufacturer: Timmer GmbH
 Dieselstraße 37
 48485 Neuenkirchen
 Phone: +49 (0) 5973 9493-0

hereby declares that the product: Piston Pump

General designation:  II 2G Ex h IIB T4 Gb X
 Piston Pump

Function: Pumping of fluid product

Type series: PTI-KPE1030 & PTI-KPE1060

Item designation*: PTI-KPE 1030 VA-XX-XX-XX (-XX)-SAM
 PTI-KPE 1060 VA-XX-XX-XX (-XX)-SAM

Item designation distributor: PaintCare ePCS-30 w/o Motor
 PaintCare ePCS-40 or 60 w/o Motor

Trade name: Mechanical piston pump

complies with all relevant provisions of the ATEX Directive 2014/34/EU.

The following harmonised standards have been applied:

DIN EN 1127-1:2011	Explosive atmospheres – Explosion prevention – Part 1: Basic concepts and methodology
DIN EN ISO 80079-36:2016	Explosive atmospheres – Part 36: Non-electrical equipment for explosive atmospheres – Basic method and requirements (ISO 80079-36: 2016); German version EN ISO 80079-36: 2016
DIN EN ISO 80079-37:2016	Explosive atmospheres – Part 37: Non-electrical equipment for explosive atmospheres - Non-electrical type of protection constructional safety "c", control of ignition sources "b", liquid immersion "k"; (ISO 80079-37:2016); German version EN ISO 80079-37:2016

Person authorised to the compile the technical documentation: Timmer GmbH, Dieselstraße 37, 48485 Neuenkirchen, Phone: +49 (0) 5973 9493-0

Commissioning is prohibited until it has been determined that the assembly, in which the Piston Pump will be installed complies with the provisions of the ATEX Directive 2014/34/EU.

Neuenkirchen, 09/2021

City/date

 Klaus Gehrman, Managing Director

*Places marked by an "X" in the type key are placeholders and can be replaced with the actual characters.

SAMES KREMLIN SAS

13 Chemin de Malacher
38240 Meylan
France

Tel.: 33 (0)4 76 41 60 60
www.sames-kremlin.com