



User manual

Nanobell II SB

SAMES KREMLIN SAS - 13, Chemin de Malacher - 38240 MEYLAN - FRANCE
Tel. 33 (0)4 76 41 60 60 - www.sames-kremlin.com

All communication or reproduction of this document, in any form whatsoever and all use or communication of its contents are forbidden without express written authorisation from SAMES KREMLIN.

The descriptions and characteristics mentioned in this document are subject to change without prior notice.

© SAMES KREMLIN 2014



WARNING : SAMES KREMLIN SAS is registered with the Ministry of Labour as a training institution.

Throughout the year, our company offers training courses in the operation and maintenance of your equipment.

A catalogue is available on request. Choose from a wide range of courses to acquire the skills or knowledge that is required to match your production requirements and objectives.

Our training courses can be delivered at your site or in the training centre at our Meylan head office.

Training department:

Tel. 33 (0)4 76 41 60 04

E-mail: formation-client@sames-kremlin.com

SAMES KREMLIN SAS operating manuals are written in French and translated into English, German, Spanish, Italian and Portuguese.

The French version is deemed the official text and SAMES KREMLIN will not be liable for the translations into other languages.

Nanobell II SB

1. Health and Safety Instructions- - - - -	5
1.1. Configuration of the certified equipment	5
1.2. Marking on the atomizer	5
1.3. Precautions for Use	6
1.4. Warnings	6
1.4.1. Regulatory tests to be carried out on the equipment according to standard EN 50176.	9
1.4.2. Installation rules	11
1.5. Important Recommendations	12
1.5.1. Compressed Air Quality	12
1.5.2. Product Quality	12
1.5.3. Bearing Safety	12
1.5.4. Locking	13
1.5.5. Shaping Air	13
1.5.6. High Voltage	13
1.5.7. Maximum Speed	13
1.5.8. Vibrations	13
1.5.9. Bell Cup / Turbine Fitting	13
1.5.10. O-ring Seals	14
1.5.11. Ventilation	14
1.5.12. Residual pressure	14
1.5.13. Safety devices	14
1.5.14. Restriction on robot wrist movements	14
1.5.15. Mechanical Collision	14
1.5.16. Ambient Temperature	14
1.5.17. Sound level	14
1.5.18. Specific maintenance provisions	15
1.6. Guarantee	16
2. Description - - - - -	17
2.1. General	17
2.2. Function of the parts	19
3. Technical Characteristics - - - - -	20
3.1. Dimensions, gravity center and tool center point (mm)	20
3.1.1. Hollow wrist version	20
3.1.2. Full wrist version	22
3.2. Working characteristics	24
3.3. Safety characteristics	25
3.4. Operating Principle	26
3.4.1. Turbine	26
3.4.2. Turbine Rotation Speed	27
3.4.3. Microphone	27
4. Diagrams - - - - -	28
5. Startup - - - - -	29
5.1. Tools	29
5.2. Installation	30

5.3. Shutdown and Startup Procedures	31
5.3.1. Shutdown Procedure	31
5.3.2. Startup Procedure	31
6. Maintenance - - - - -	32
6.1. Summary table of maintenance operations	32
6.2. Preventive maintenance	33
6.2.1. Procedure A: Atomizer exterior	33
6.2.2. Procedure B1: Magnetic bell cup	35
6.2.3. Procedure B2: Shaping air assembly	36
6.2.4. Procedure B3: Injector / Injector holder assembly	37
6.3. Corrective maintenance	38
6.3.1. Procedure C1: Body installation / removal	38
6.3.2. Procedure C2: Replacement of turbine	38
6.3.3. Procedure C3: Replacement of solvent pipette	39
6.3.4. Procedure C4: Replacement of microvalves	39
6.3.5. Procedure C5: Replacement of body o-rings	40
6.3.6. Procedure C6: Replacement of fittings	40
6.3.7. Procedure C7: Replacement of high-voltage unit	41
7. Spare parts list - - - - -	42
7.1. Nanobell II hollow wrist	42
7.2. Nanobell II full wrist	44
7.3. Body assembly	46
7.3.1. Equipped body	47
7.4. Injector / injector holder	50
7.5. Robot adapters	51
7.5.1. Adapter for Motoman EXP 2050 and 2900 robots	51
7.5.2. Adapter for Fanuc P250 robot	51
7.5.3. Adapter for Staubli RX 160 robot	51
7.5.4. Adapter for Staubli TX 250 robot	52
7.5.5. Adapter for ABB IRB 4400 robot	52
7.6. Grounding kit	53
8. Option Nanobell II, Gun spraying head version - - - - -	54
8.1. Characteristics	54
8.1.1. Dimensions	54
8.2. Fluid diagram	55
8.3. Tools	55
8.4. Procedure to transform a Nanobell II bell cup version, to a Nanobell II Gun version	56
8.5. Maintenance	58
8.5.1. Summary table of maintenance operations	58
8.5.2. Preventive maintenance	58
8.5.3. Maintenance corrective	59
8.6. Spare parts for the Gun spraying head	61
8.6.1. Head	61
8.6.2. Equipotential plate	62

1. Health and Safety Instructions

This manual contains links to the following user manuals:

- [see RT Nr 7071](#) for the user manual of Hi-TE bellcups for magnetic air bearing turbine.
- [see RT Nr 6350](#) for the user manual of the turbine type "BTM".
- [see RT Nr 6021](#) for the user manual of the microvalve ou [see RT Nr 6422](#) for the microvalve with bellow.
- [see RT Nr 7068](#) for the user manual of the high voltage unit UHT 158.
- [see RT Nr 6190](#) for the microphone.
- [see RT Nr 6364](#) for the user manual of the electric systems,
- [see RT Nr 7122](#) for the user manual of the control module GNM 300.
- [see RT Nr 6213](#) for the user manual of the control module GNM 200.

1.1. Configuration of the certified equipment

The whole of these user manuals defines the configuration of the certified equipment.

1.2. Marking on the atomizer

The specific EXAT marking for each sprayer is indicated in this section.
The equipment is C-L type according to standard EN 50176 (§ 5.1).

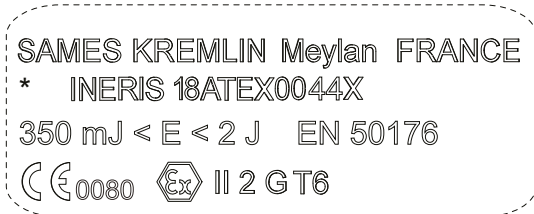

*: Nanobell II.

The X symbol placed behind the EU type examination certification indicates that when a "dl/dt safety" fault appears any movement likely to reduce the safe distance must be stopped (stop moving the sprayer and stop the conveyor transporting the parts to be sprayed) before the fault reset is authorised.

Atomizer Nanobell II - P/N 910016011 Hollow wrist Equipped body - P/N 910008553 S12 Turbine - P/N 1525802	Atomizer Nanobell II - P/N 910016012 Full wrist Equipped body - P/N 910008553 S12 Turbine - P/N 1525802	UHT 158 - P/N 910007566	P/N Nanobell II (*)	GNM 300 P/N 910024028 or GNM 200A P/N 1517071
X		X	910016011	X
	X	X	910016012	X

1.3. Precautions for Use

This document contains information that all operators should be aware of and understand before using the atomizer concerned. This information highlights situations that could result in serious damage and indicates the precautions that should be taken to avoid them.



WARNING : Before any use of the Nanobell II equipment, check that all operators:

- have previously be trained by the compagny SAMES KREMLIN, or by their distributors registered by them for this purpose.
- have read and understood the user manual and all rules for installation and operation, as laid out below.

It is the responsibility of the operators' workshop manager to ensure these two points and it is also his responsibility to make sure that all operators have read and understood the user manuals for any peripheral electrical equipment present in the spraying area.

1.4. Warnings



WARNING : Safety may be jeopardized if this equipment is not operated, disassembled and reassembled in compliance with the instructions given in this manual and in any European Standard or national safety regulations in force.



WARNING : Equipment performance is only guaranteed if original spare parts distributed by SAMES KREMLIN are used.



WARNING : To guarantee an optimal assembly, spare parts must be stored in a temperature close to their temperature of use. Should the opposite occur, a sufficient waiting time must be observed before the installation, so that all the elements are assembled in the same temperature.



WARNING :

This equipment must only be used in spraying locations according to standard EN 50176 (§ 5.4 and 5.7). The equipment has to be used only within ventilated in order to reduce risks for the health of the operators, fire or explosion. The efficiency of the extraction ventilation system has to be daily checked.

Within explosive atmospheres produced by the spraying process, only appropriate explosion-proof electrical equipment has to be used.

Before carrying out any cleaning or general work on atomizers in the spraying area, the high voltage generator must be switched off and the atomizer HV circuit discharged to the ground.

The pressurised coating product or the pressurised air must not be directed towards people or animals.

Appropriate measures have to be taken to avoid, during periods when the equipment is not used and/or when the equipment is broken, the presence of potential energy (liquid or air pressure or electric) inside the equipment.

The operator must wear shoes according to standard EN ISO 20344 and the insulation resistance measured must not exceed 100 MΩ.

The protective clothes, including gloves, must conform to standard EN 1149-5 and the insulation resistance measured must not exceed 100 MΩ.

Using individual protection equipment will limit the risks of contact and/or inhalation of toxic product, gas, vapours, fog or dusts that can be produced while using the equipment. The user has to follow the coating product manufacturer's recommendations.

Electrostatic spraying equipment must be serviced regularly in accordance with the information and instructions given by SAMES KREMLIN.

It is strictly prohibited to stick adhesive tape on the atomizer body.

Cleaning operations must be carried out either in authorised areas equipped with a mechanical ventilation system, or using cleaning liquids with a flash point at least 15 °C higher than room temperature.

Only metal containers can be used for cleaning liquids and they must have a reliable ground connection.

Inside the booth it is forbidden to use a naked flame, glowing object or a device likely to produce sparks.

It is also forbidden to store inflammable products, or vessels that have contained them, close to the booth.

The surrounding area must be kept clear and clean.



WARNING : The use of very high voltage increases the risk of sparks. SAMES KREMLIN atomizers and high-voltage electrostatic generators are designed to minimize this risk. Although the HV electrode is the only accessible part, a safety distance of X mm (refer to: Board [see § 3.3 page 25](#)) has to be maintained between the parts of the sprayer that are under high voltage and all the parts that are grounded.

The distances authorized from application, specified in the user manual of the atomizer, are a function overall length of cables HV (electric capacities). HV connection of the atomizer to the well of the HVU is authorized only by the use of a HV cable only one length, no adapter is not authorized

In addition, a careful check must be made to ensure that any conducting or semi-conducting part closer than 2.5 m to the atomizer is correctly grounded.

If it is not, electrical charges capable of causing sparks could build up on it. Operating personnel must wear anti-static shoes and gloves to avoid this risk.

All metal parts of the booth and parts to be painted must be correctly grounded. Ground resistance must be less than or equal to 1 M Ω (minimum measurement voltage 500 V). This must be checked regularly.

Grounding is mandatory for all the conductive envelops of the electrical equipments and for all the conductive components within explosive atmospheres by conductive connection with the ground terminal.

Finally, for the same reasons, the spraying area must have an anti-static floor, such as concrete, metal duckboard, etc.

It is essential to provide sufficient ventilation in the spraying booths to avoid the build up of inflammable vapors.

The effectiveness of the overcurrent protection (di/dt) must be checked every day. This check must be carried out in an area with **no explosive atmosphere** by placing a ground device near the electrode of the atomizer when the atomizer is switched on (the operator must be connected to ground): the control module must switch to the fault state.

Additional equipment has to be placed outside the dangerous area and its starting device has to be servo-controlled to the running mode of the booth aspiration fan. The correct working of the servo-control has to be checked once a week.

A warning board has to be placed in full view close to the spraying area.

An excessive turbine speed can engender major damages on the turbine as well as a loss of connection bell/turbine; this represents a risk for persons and equipment. The maximum speed indicated in this user manual must not be exceeded ([see § 3.2 page 24](#)).

1.4.1. Regulatory tests to be carried out on the equipment according to standard EN 50176
The tests must be carried out on the spraying equipment. The tests must be carried out by competent personnel and include the tests described below (see § 6.3 table 3 in standard EN 50176).

Type of test	Requirements
The fixed inflammable coating liquid material electrostatic coating must be tested to ensure it is safe for workers.	In this context, and particularly for the disconnection threshold, the overload current $I_{\bar{U}}$ and the minimum voltage U_{min} must be defined and documented in relation to the operational and local conditions (see also § 5.2.2 in standard EN50176).
Forced ventilation effectiveness (air extraction systems)	See §5.4.4 in standard EN50176
The safe high voltage disconnection must be tested for operation under controlled voltage and under constant voltage.	See 5.2.2 and 5.2.2.1 in standard EN50176. The disconnection threshold $I_{\bar{U}}$ must be defined and documented in relation to the operational and local conditions. It must be tested if the high voltage is disconnected and if there is an unacceptable increase in the operating current I_b and if the disconnection threshold $I_{\bar{U}}$ is reached. In this context, the disconnection threshold $I_{\bar{U}}$ defined during the initial test must be checked. A disconnection threshold $I_{\bar{U}}$ that may increase the possibility of dangerous discharges or electrical flashovers between the parts under high voltage and the grounded parts if the safe distance falls below its permitted value is not permitted.
3G category devices	See 5.2.2 and 5.2.2.1 in standard EN50176
2G category devices	See 5.2.2, 5.2.2.1 and 6.4 in standard EN50176
For the operation at constant current, the safe disconnection of the high voltage electricity supply must be tested.	See 5.2.2 and 5.2.2.2 in standard EN50176. The disconnection threshold U_{min} must be defined and documented in relation to the operational and local conditions. Checks must be carried out to ensure that the high voltage is disconnected if the high voltage falls unacceptably below the disconnection threshold U_{min} . In this context, the disconnection threshold U_{min} defined during the initial test must be checked. A disconnection threshold U_{min} that may increase the possibility of dangerous discharges or electrical flashovers between the parts under high voltage and the grounded parts if the safe distance falls below its permitted value is not permitted.
3G category devices	See 5.2.2 and 5.2.2.2 in standard EN50176

Type of test	Requirements
2G category devices	See 5.2.2, 5.2.2.2 and 6.4 in standard EN50176
Protection against discharge energy which is too high	See 5.2.3, 5.8.2 and 5.8.3 in standard EN50176
Protection against cleaning product inflammation	See 5.2.4.in standard EN50176
Effectiveness of the protection measures against direct contact	See 5.5.2, 5.5.6 and 5.8.5 in standard EN50176
Effectiveness of the earthing measures	See 5.7 in standard EN50176
Slaving / protection against inputs	See 5.5.2 in standard EN50176
Effectiveness of the local fire extinguishing system	See 5.2.5 in standard EN50176 In addition to the location's protection system, local fire extinguishing systems (fixed and dedicated to the object) must provide effective protection for the dangerous zone located between the output from the coating material and the part to be processed. It must be proven for each individual case that the roles of the local fire extinguishing systems and the location's protection systems may be satisfied by a single extinguishing system.
conducting parts of the coating material's supply system	See 5.8.1 in standard EN50176
Minimum distance in the air	See 5.5.7 and 5.8.5 in standard EN50176
Other tests	According to standard EN 12215:2004.

These tests must be carried out periodically The following maximum intervals between tests are recommended (see § 7.2.3 table 4 in standard EN 50176).

Reference	Test frequency
Complete installation safety test in relation to workers	12 months
Forced ventilation effectiveness	in continuous
Disconnection in the event of an overload current	after each start-up
Low voltage disconnection	after each start-up
Discharge energy	weekly
Protection against cleaning product inflammation	before each cleaning
Protection against direct contact	weekly
Earthing measures	weekly
Protection against inputs	weekly
Site's fire extinguishing system	before each cleaning
Conducting parts of the coating material's supply system	weekly
Minimum distance in the air	weekly
Other tests	in accordance with standard EN 12215:2004

1.4.2. Installation rules

Nanobell II using solvent-borne paints with a resistivity $\rho \geq 6 \text{ M}\Omega\cdot\text{cm}$.

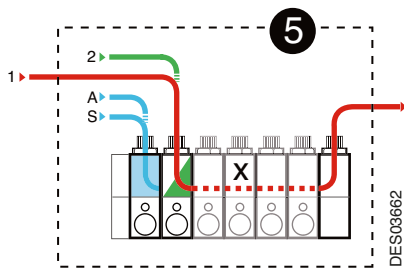
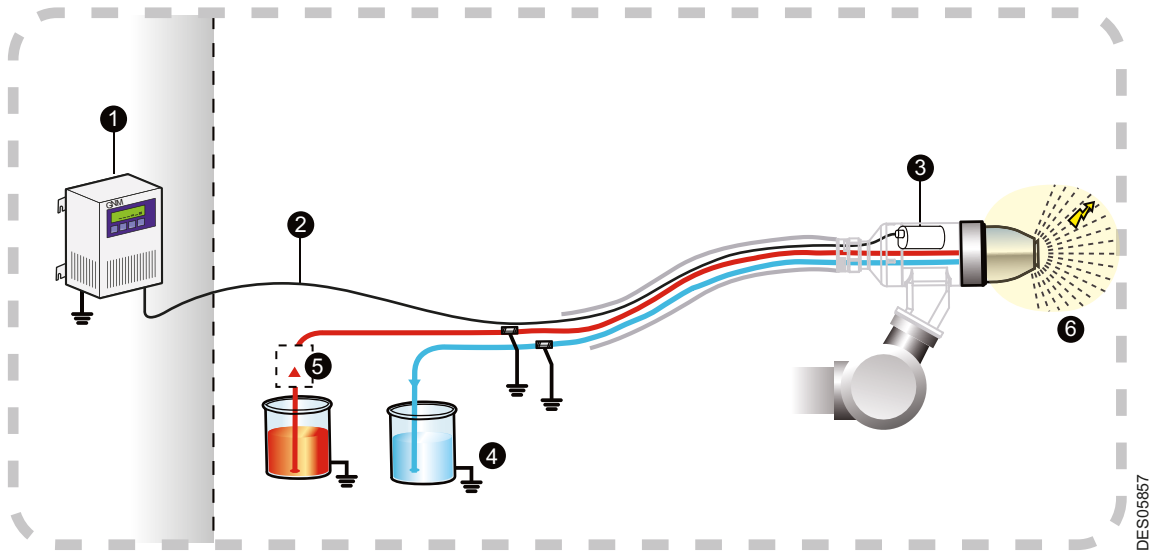

S: Rinsing product
 A: Air supply
 1: Product 1 supply
 2: Product 2 supply

Nota: Paint, solvent and dump circuits require a special kit to be grounding (see § 7.7 page 50)

Nota: Hoses and low voltage cable pass outside the robot



WARNING : All the conductive components must be connected to the ground potential (metallic fittings of Moduclean, gear pump, etc...).

Paint resistivity $\rho \geq 6 \text{ M}\Omega\cdot\text{cm}$	
1	Control module GNM 200 or GNM 300 (out of the ATEX area)
2	Low voltage connection
3	High voltage unit UHT 158
4	Dump return line connected to the ground potential
5	Supplies of paints and rinsing products connected to the ground potential
6	Safety distance (area around the the atomizer head from the parts with high voltage outer cover, bellcup etc...)



WARNING : It is strictly prohibited to install an unspecified system not complying with the rules described above.

1.5. Important Recommendations

1.5.1. Compressed Air Quality

The air must be filtered to a level that will guarantee a long life time and prevent any pollution during painting.

The filter must be installed as close as possible to the facility. The filter cartridges must be changed regularly to ensure that the air is clean.

PTFE tape or glue should not be used between the filter and the bearing as glue residue or pieces of PTFE may block the small holes of the air bearing and cause turbine failure.

The inside of hoses supplying air to the atomizer and the ports of the quick-disconnect plate must be clean and free of any traces of paint, solvent or other foreign matter.

The guarantee does not cover faults caused by unclean, unfiltered bearing air resulting from disregard of the previous recommendations.



WARNING : If the air is not correctly filtered, the bearing may become fouled resulting in a turbine operating fault. The filtering system used must prevent particles greater than 5 µm in diameter from reaching the bearing.



WARNING : The guarantee does not cover damage caused by foreign matter such as paint, solvent or other substances entering the air circuits of the Nanobell II.

1.5.2. Product Quality

The paint must be filtered to prevent any damage to the atomizer.

The maximum permissible particle size in the atomizer is 200 µm.

1.5.3. Bearing Safety

The compressed air connection to the air bearing must be made directly to the supply circuit without the use of an isolating valve.

During operation, the air bearing must be continuously under pressure, otherwise considerable damage may be caused. A sudden cut in the air supply could destroy the air bearing of the turbine. Wait until the turbine has stopped completely before cutting off the bearing air.

Procedure for cutting off air to the air bearing:

- Switch off the turbine rotation air supply
- Wait until the turbine has stopped completely (at least 150 s).
- Switch off the bearing air supply.

Running the turbine with bearing air pressure of less than 6 bar at the atomizer inlet can damage the bearing. The standard bearing air pressure is 6 bar at the air control cabinet.

All these pressure values are measured at the atomizer inlet. If the bearing pressure drops below 6 bar at the turbine or atomizer inlet, cut off the air supply to the turbine.

In addition, a 25-liter air reserve should be available so that the turbine brakes gradually if the main air supply is cut off suddenly.



WARNING : The guarantee does not cover faults that occur if the turbine is operated with insufficient bearing air pressure.

1.5.4. Locking

Do not atomize the product if the bellcup is not turning at a speed of at least 15000 rpm. At lower speeds, paint or solvent may enter the turbine, bearing and control circuits. Opening the head valve, injector rinsing valve and bellcup exterior rinsing valve must be prohibited when the bellcup is not turning. Only qualified personnel are authorized to by-pass this locking system for flow rate checks.



WARNING : If the turbine is not already operating, wait, after starting it up, until the bellcup reaches at least 15000 rpm before opening the head valve. The recommended minimum waiting time is 2 seconds.

1.5.5. Shaping Air

Do not atomize the product until the shaping air rate is at least 80 NI/mn (i.e. 0.3 bar at the atomizer inlet). If it is less, there may be a feedback of atomized product which fouls the outer cover and the inside surface of the air shroud resulting in application faults.

1.5.6. High Voltage

Disable the high voltage if the Nanobell II is not operated for a prolonged period (conveyor shutdown, no objects to be painted, slack periods, etc.) to prevent ionization of the air.



WARNING : Rinsing cycles (bellcup exterior and injector) must be carried, beforehand switching off the high voltage power supply.

1.5.7. Maximum Speed

Excessive turbine speed can result in serious damage to the turbine and loss of connection between the bell cup and turbine, presenting a risk to persons and equipment. The speed must not exceed 45,000 rpm.



WARNING : The guarantee does not cover damage resulting from a rotation speed greater than 45 000 tr/min.

1.5.8. Vibrations

If the atomizer vibrates more than usual, the cause is generally unbalanced rotating parts. There may be dry paint deposits on the bell cup or rotor. If any of these situations arise, it is essential to correct them. Excessive unbalance may damage the turbine resulting in failure to operate or even loss of the bell cup / turbine connection, presenting a risk for persons and equipment.



WARNING : The guarantee does not cover damage caused by unbalance of the rotating parts.

1.5.9. Bell Cup / Turbine Fitting

The bell cup must be correctly fitted on the turbine, a snap must be heard; the two cylinders must fit on top of each other without any foreign matter between them. If fitting is incorrect, the connection may be lost and the bell cup thrown out still spinning, presenting a risk for persons and equipment.

1.5.10. O-ring Seals

Use the seals recommended in this manual. For solvent-based products, seals in contact with the product must be chemically inert seals resistant to swelling or chemical attack. The Nanobell II is only guaranteed to operate correctly if it is used with seals whose size and material conform to this manual.

1.5.11. Ventilation

Do not begin applying paint with the Nanobell II before starting up the ventilation system in the spraying booth. If the ventilation is cut, toxic substances such as organic solvents or ozone may remain in the spraying booth, resulting in a risk of fire, poisoning or irritation.

1.5.12. Residual pressure

Before all maintenance or repair operations, remove paint and solvent from the atomizer, switch off the high voltage power supply and cut the paint, solvent and air supplies, then release residual pressure in each supply system. Residual pressure may lead to component damage and expose personnel to serious injuries. Paint or solvent dispersion may also lead to poisoning or irritation.

1.5.13. Safety devices

During installation of the Nanobell II, it is important to set up safety devices enabling high voltage power, paint, solvent and air supplies to be cut immediately if there is a problem.

- Detection of control system faults
- Detection of high voltage surges linked with the SAMES KREMLIN high voltage module.
- Detection of air pressure drops.
- Detection of ventilation failure.
- Detection of fire
- Detection of human presence.
- Detection of turbine rotation speed faults.

Failure to install safety devices could result in a risk of fire, expose the personnel to serious injury and damage the equipment.



WARNING : The electrostatic projection systems must be equipped with an automatic fire extinguishing system (according to § 5.2.5 in standard EN 50176).

1.5.14. Restriction on robot wrist movements

In order to optimize the life time of the low voltage cable as well as the supply hoses, it is recommended to limit the movement of axis 6 to $\pm 0,5$ turns compared with the axis 3.

1.5.15. Mechanical Collision

The guarantee does not cover damage resulting from the operating environment (for example collision with the robot).

1.5.16. Ambient Temperature

The sprayer is designed to work normally under room temperature between 0°C and + 40°C. In order to optimise application quality, it is advised to work under room temperature between + 15°C and + 28°C.

The storage temperature will never exceed +60°C.

1.5.17. Sound level

The acoustic pressure level, continuous, equivalent, weighted, equals to 59.7 dBA.

Conditions of measurement:

The equipment has been run at its maximum values, the measures have been made from the operator desk of the paint test booth "API" (closed booth with glass walls) of the Research & Development laboratory at SAMES KREMLIN Meylan France.

Method of measurement:

The acoustic pressure level, continuous, equivalent, weighted (59.7 dBA) is given in LEQ value, measured for observation periods of at least 30 seconds.

1.5.18. Specific maintenance provisions

The access of the booth, near the atomizer in operation, will have to be proscribed and controlled by safety devices ([see § 1.5.13 page 14](#)) which will have to stop the equipment in case of intrusion of people in the area.

Nevertheless, for maintenance operation, these safety devices will have to be arranged in order to allow certain operations and checks (only for persons trained and entitled by SAMES KREMLIN).

The turbine rotation with a bellcup, in all the cases, will be prohibited with personnel in the area.

1.6. Guarantee

Under the guarantee, which applies only to the buyer, SAMES KREMLIN agrees to repair operating faults resulting from a design fault, materials or manufacture, under the conditions set out below.

The guarantee claim must define, in writing, the exact nature of the fault concerned. The SAMES KREMLIN guarantee only covers equipment that has been serviced and cleaned according to standard procedures and our own instructions, that has been fitted with parts approved by SAMES KREMLIN or that has not been modified by the customer.

More precisely, the guarantee does not cover damage resulting from:

- the customer's negligence or inattentiveness,
- incorrect use,
- failure to follow the procedure
- use of a control system not designed by SAMES KREMLIN or a SAMES KREMLIN control system modified by a third party without written permission from an authorized SAMES KREMLIN technical agent,
- accidents such as: collision with external objects, or similar events,
- flooding, earthquake, fire or similar events,
- inadequately filtered bearing air (solid particles more than 5 µm in diameter),
- inadequately filtered paint and solvent,
- use of seals not complying with SAMES KREMLIN recommendations,
- starting up turbine rotation without minimum bearing air pressure (6 bar),
- exceeding the maximum speed of 45,000 rpm under load,
- starting up rotating parts that are unbalanced (dry paint on bellcup, rotor or damaged bellcups),
- pollution of air circuits by fluids or substances other than air.

SAMES KREMLIN atomizer **Nanobell II** is covered by a one-year guarantee for use in two 8-hour shifts under normal operating conditions.

By concession, the guarantee is extended to 10000 hours on the air turbine of the **Nanobell II**. The guarantee does not apply to wearing parts such as atomizing bellcups, diaphragms, clips, seals, etc.

The guarantee will take effect from the date of the first startup or of the provisional acceptance report.

Under no circumstances, either in the context of this guarantee or in other contexts, will SAMES KREMLIN be held responsible for physical injury or intangible damage, damage to brand image and loss of production resulting directly from its products.

2. Description

2.1. General

Atomizer **Nanobell II** is a robotic rotary atomizer, dedicated according to versions, to the application of solvented or waterborne paints, mono paintings or multi-components. It is used in environments of automatic electrostatic atomization, its design makes of this atomizer equipment simple, easy to maintain.

Light and compact, it can equip with the small size robots.

Equipped with a magnetic air bearing turbine, the atomizer **Nanobell II** can atomize with a maximum rotation speed of 45,000 rpm.

Atomizer Nanobell II allows to improve the quality of production while making significant savings of paint.

Main components:

Hollow wrist

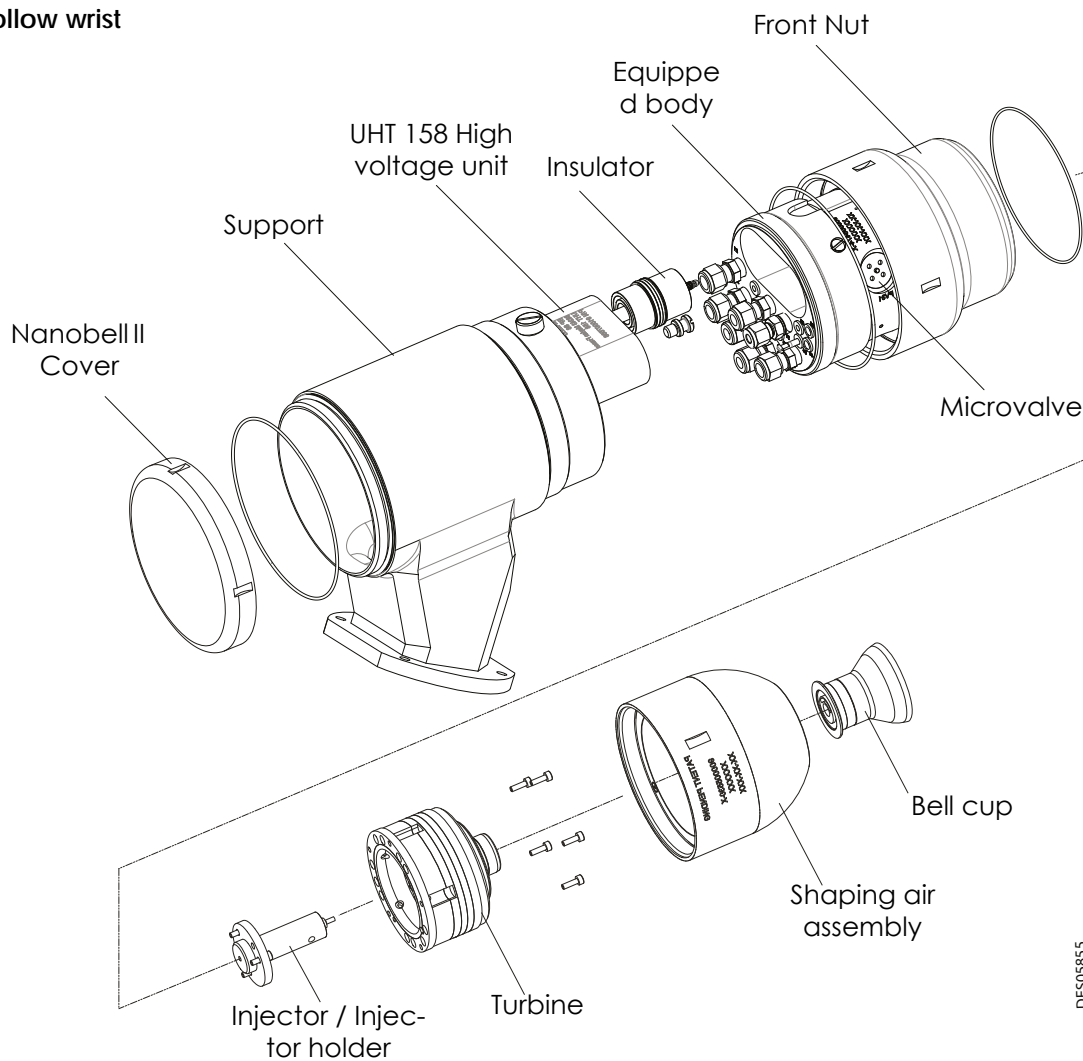

Full wrist

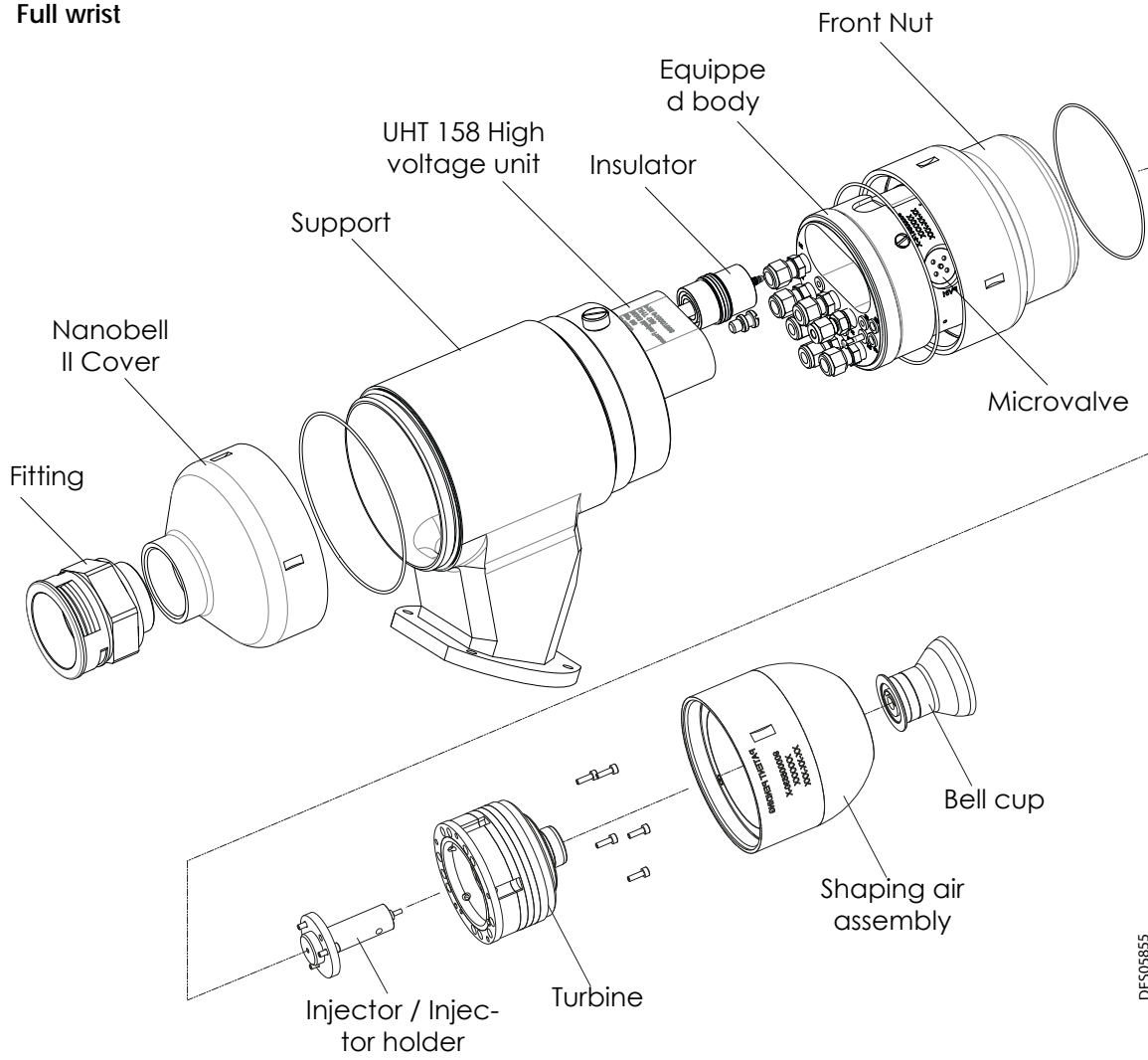

DE505855

2.2. Function of the parts

Parts	Function
Bell cup	The bell cup atomizes all types of paint. It is selected according to the type of product used.
Turbine	The rotation of the bell cup is produced by a pneumatic motor. Atomization results from the centrifugal forces generated by rotation of the bell cup. The size of sprayed paint particles decreases as the speed of the turbine motor increases.
Body	The body houses all the fluid circuits, product, air and solvent microvalves and the injector / injector holder assembly.
Shaping air assembly (outer cover / shaping air shroud)	These parts control the size and pattern diameter and transfer the particles to the parts to be painted. They protect internal components and allow easy cleaning.
Injector holder Injector	Keeps the injector in the center of the bell cup. It also has an opening to supply the microphone air.
	The injector is used to regulate the paint flow rate into the bell cup. The inner diameter of the restrictor is selected according to the viscosity of the paint and the required paint thickness
Microvalve	Air-controlled, 2-way, normally closed valves used for various operations: paint supply, paint rinse, bell cup exterior rinse, injector rinse
UHT 158 High voltage unit	Receives a low voltage supply that it converts into high voltage for charging the atomized paint particles; these are attracted to the surface to be painted, which has a ground connection

3. Technical Characteristics

3.1. Dimensions, gravity center and tool center point (mm)

3.1.1. Hollow wrist version

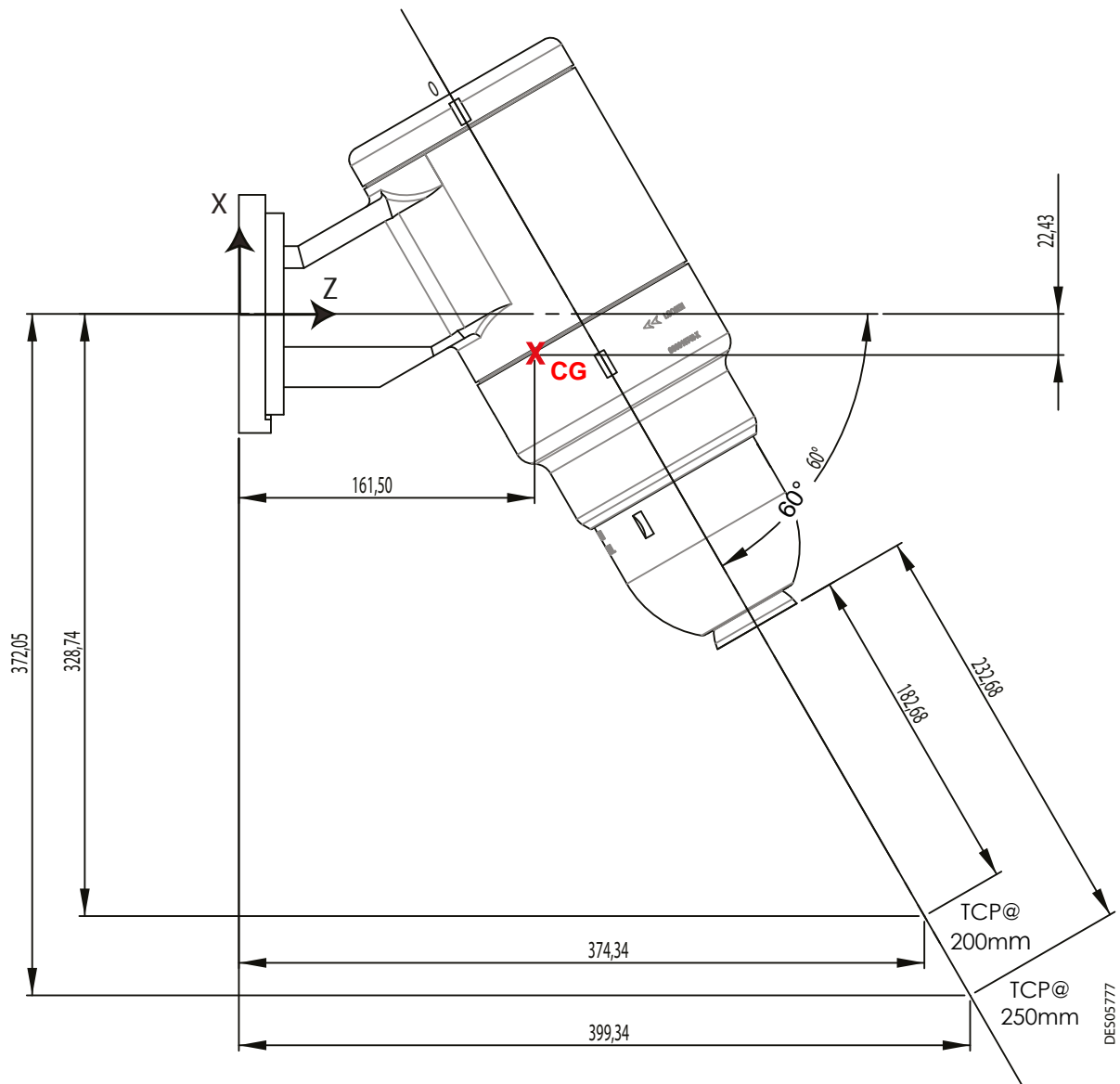

Output CS: Wrist Payload CG location

Note:

TCP : Tool Center Point

Weight: 5 kg

Gravity center (CG) in millimeters

X = -22.43

Y = -0.48

Z = 161.50

Main inertia axis and moments (kg x mm²), measured to the gravity center:

$l_x = (-0.49, 0.00, 0.87)$	$P_x = 16357.70$
$l_y = (0.87, -0.03, 0.49)$	$P_y = 43298.09$
$l_z = (0.03, 1.00, 0.01)$	$P_z = 50499.25$

Inertia moments (kg x mm²), measured to the output C.S:

$l_{xx} = 152085.93$	$l_{xy} = -170.51$	$l_{xz} = -27506.47$
$l_{yx} = -170.51$	$l_{yy} = 167955.80$	$l_{yz} = -375.89$
$l_{zx} = -27506.47$	$l_{zy} = -375.89$	$l_{zz} = 25040.60$

3.1.2. Full wrist version

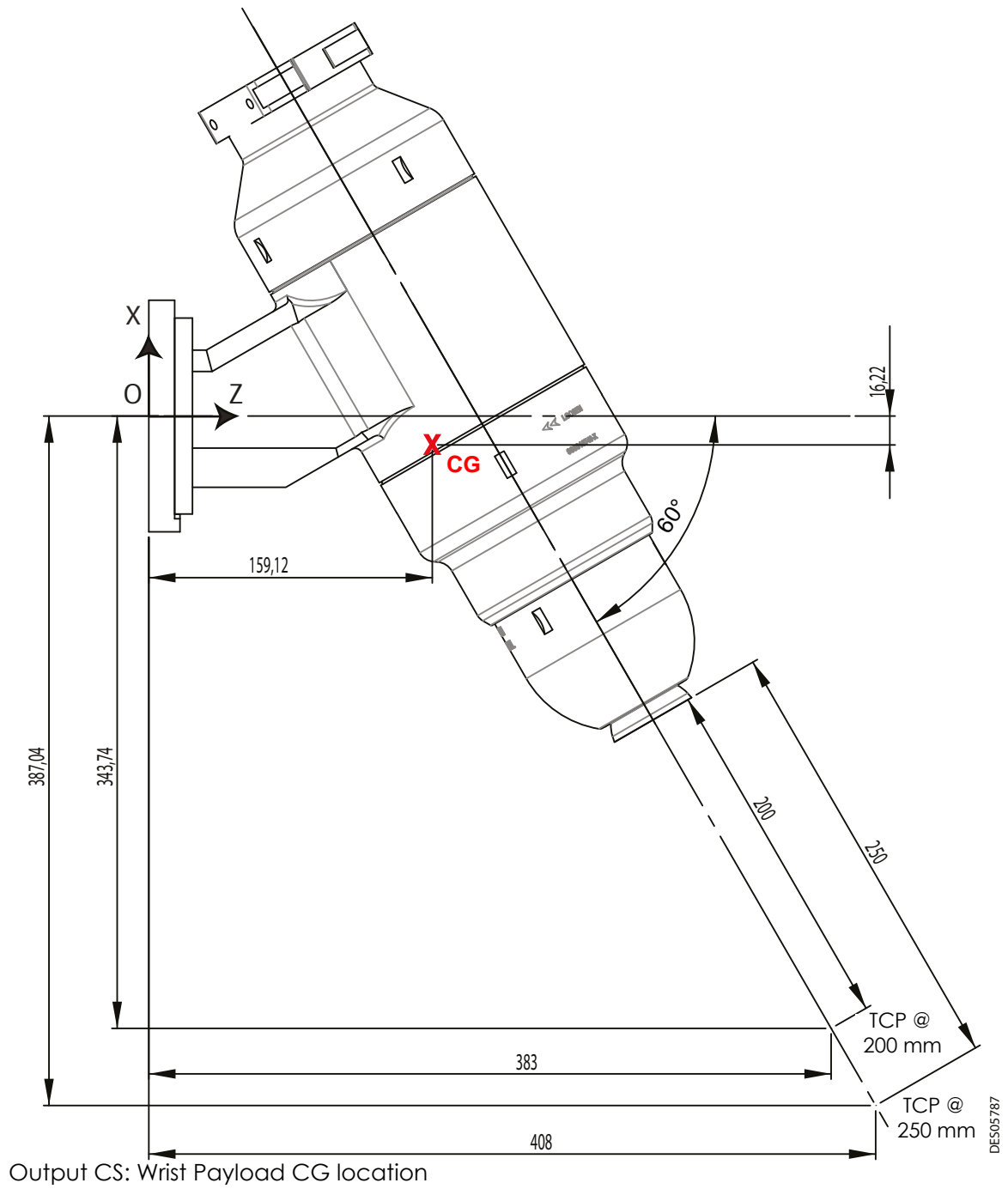

Note:

TCP : Tool Center Point

Weight: 5 kg

Gravity center (CG) in millimeters

X = -16.22

Y = - 0.47

Z = 159.12

Main inertia axis and moments (kg x mm²), measured to the gravity center:

$l_x = (-0.57, 0.00, 0.82)$	$P_x = 18850.80$
$l_y = (0.82, -0.02, 0.57)$	$P_y = 47266.67$
$l_z = (0.02, 1.00, 0.01)$	$P_z = 56507.18$

Inertia moments (kg x mm²), measured to the output C.S:

$l_{xx} = 153741.21$	$l_{xy} = -170.47$	$l_{xz} = -25136.17$
$l_{yx} = -170.47$	$l_{yy} = 173471.36$	$l_{yz} = -375.82$
$l_{zx} = -25136.17$	$l_{zy} = -375.82$	$l_{zz} = 29350.59$

3.2. Working characteristics

Weight		
	Nanobell II	5 kg
Current		
	Maximum operating voltage	70 kV
	Maximum operating current	100 μ A
Speed		
	Rotation speed	15 to 45 K tr/min.
Paint		
	Paint flow rate	30 to 750 cc/ min. maxi (depending on paint used)
	Supply pressure	6 to 8 bar
	Maximum pressure	10 bar
	Viscosity	20 to 50 seconds - cup FORD # 4
	Viscosity	20 to 45 seconds - cup AFNOR # 4
	Paint resistivity	$\rho \geq 6 \text{ M}\Omega.\text{cm}$
Air pressure		
	Microvalve pilot	6 bar mini. - 10 bar maxi
	Bearing air	6 bar mini. - 10 bar maxi at 85NI/min.
	Shaping air	6 bar constant
	Microphone air	1,9 to 3 bar constant
Air quality		
	Filtered air (bearing air) must be dry and free of oil and dust as per DIN ISO 8573-1	
	Maximum dew point at 6 bar (87psi)	Class 4, i.e + 3° C (37° F)
	Maximum oil concentration	Class 4, i.e 2 mg / m ₀ ^{3**}
	Maximum particle size of solid contaminants	Class 3, i.e \varnothing 5 mm
	Maximum concentration of solid contaminants	5 mg / m ₀ ^{3**}
Air consumption		
	Pilot	10NI/min.
	Bearing air	125NI/min.
	Shaping air	0 to 600 NI/min.according to the shaping air assembly used
	Turbine	see RT Nr 6350

* The resistivity is measured with a Resistivohmeter AP 1000 (Part Number SAMES KREMLIN: 910005790).

For values lower than 6 M Ω .cm or close to the limits, contact SAMES KREMLIN.

** m₀³ values given for a temperature of 20°C (68°F) and an atmospheric pressure of 1,013mbar.

3.3. Safety characteristics

Nanobell II with UHT 158 high voltage unit :

Authorised spraying distance

Tension (kV)	Distance (mm)
0	100
50	
60	
70	150

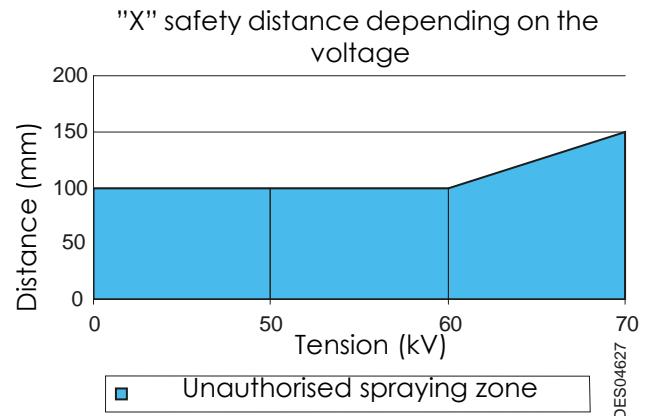

Protection against high energy discharges (§ 5.2.3 Standard EN 50176)

For a Nanobell II, the discharge energy is always less than 350 mJ.

Protection against ignition of flammable cleaning products (§ 5.2.4 Norme EN 50176)

If inflammable cleaning products are used, the discharge time for all the parts under voltage up to a discharge energy lower than 0,24 mJ is **1.7 s for a Nanobell II.**

3.4. Operating Principle

3.4.1. Turbine

[see RT Nr 6350](#)

This turbine has no mechanical shaft; it is centered by the polarity difference between the bearing magnets making it totally frictionless.

The bearing air evenly spread over the stator surface produces an air cushion that pushes the rotor away from the stator. The rotor can rotate freely, supported by the balance of pressure and magnetic forces. The air directed onto the turbine blades controls the rotation or braking of the rotor.

The product is atomized by the centrifugal forces created by the rotation of the bell cup. To some extent, the size of the atomized particles decreases as the rotation speed increases.

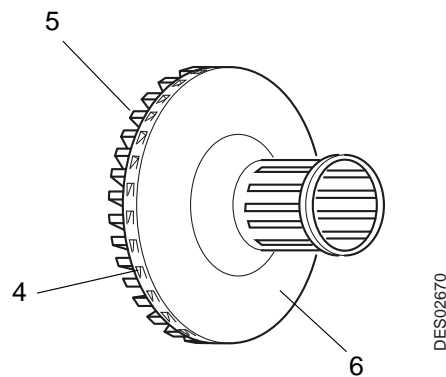
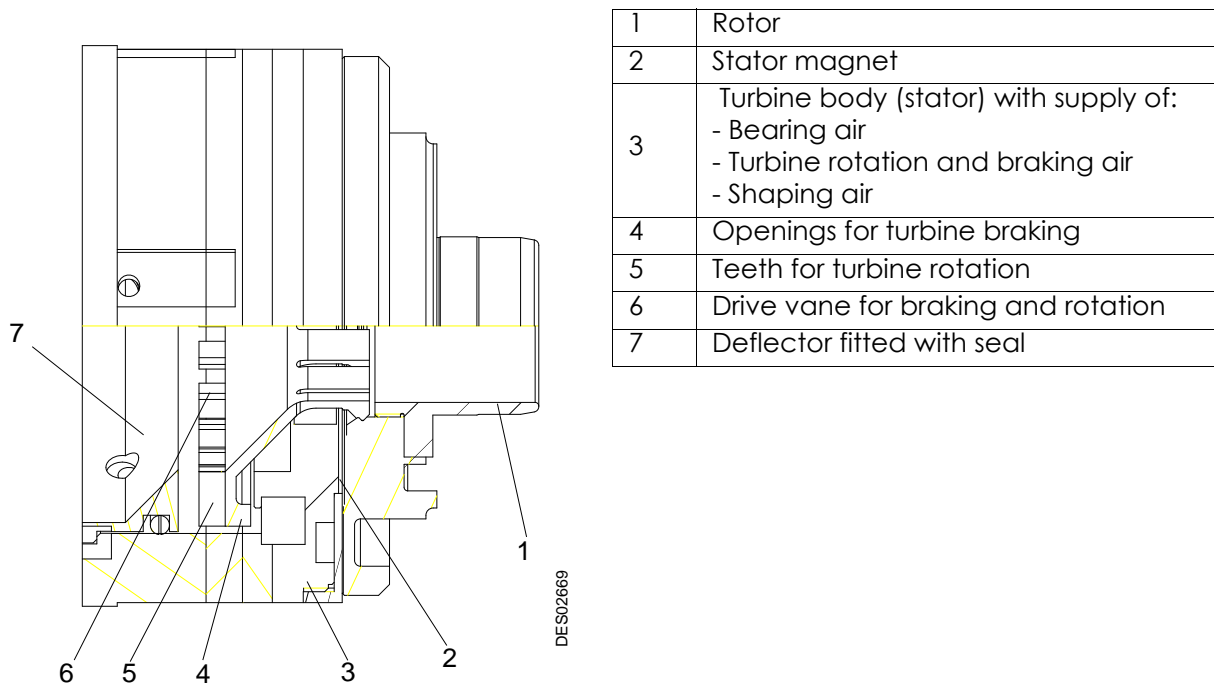

3.4.2. Turbine Rotation Speed

An acoustic method is used to measure rotation speed.

The air arrives at the injector holder. The channel machined in the 'microphone reader' located on the bellcup allows air to pass each time the bell cup rotates

This pressure variation induces a noise, or "frequency signal" which passes across the injector holder to reach a microphone.

This microphone converts the acoustic frequency signal into an electrical frequency signal for processing by the turbine speed regulation module.

The microphone assembly and the BSC 300 turbine speed regulation module constitute the MIC31 certified electrical system ([see RT Nr 6364](#)).

If used with a Frequency/Voltage converter, the MIC01 certified electrical system (Microphone + zener barrier) must be used ([see RT Nr 6364](#)).

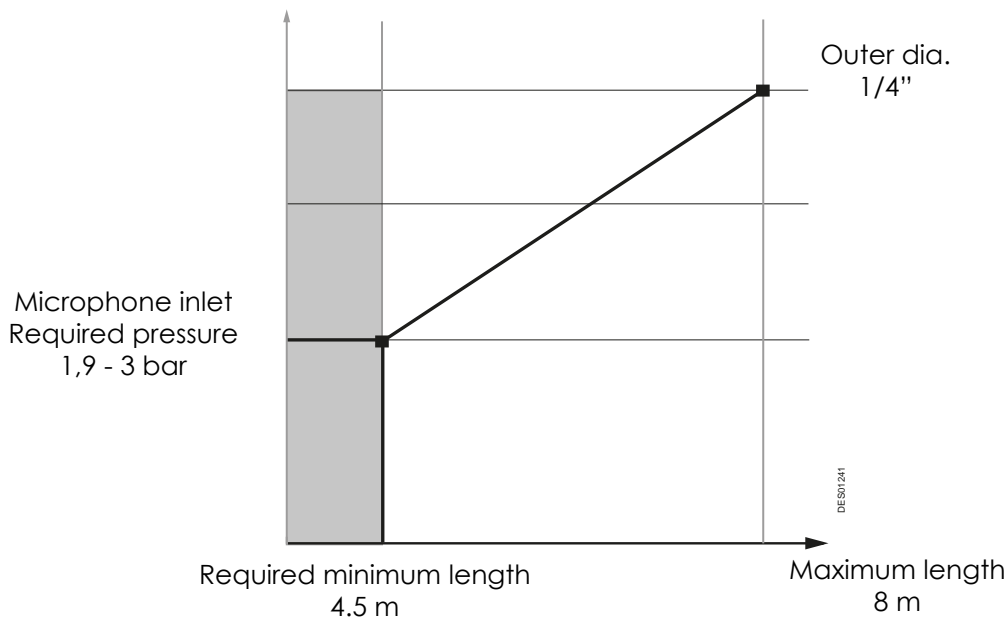

3.4.3. Microphone

[see RT Nr 6190](#)

The microphone will be associated a SAMES KREMLIN Frequency/Voltage converter which transforms the signal of analogical frequency into analogical signal of level (0 - 10 V) or numerical (pulsates).

Contact SAMES KREMLIN to obtain the adequate reference to the application.

4. Diagrams

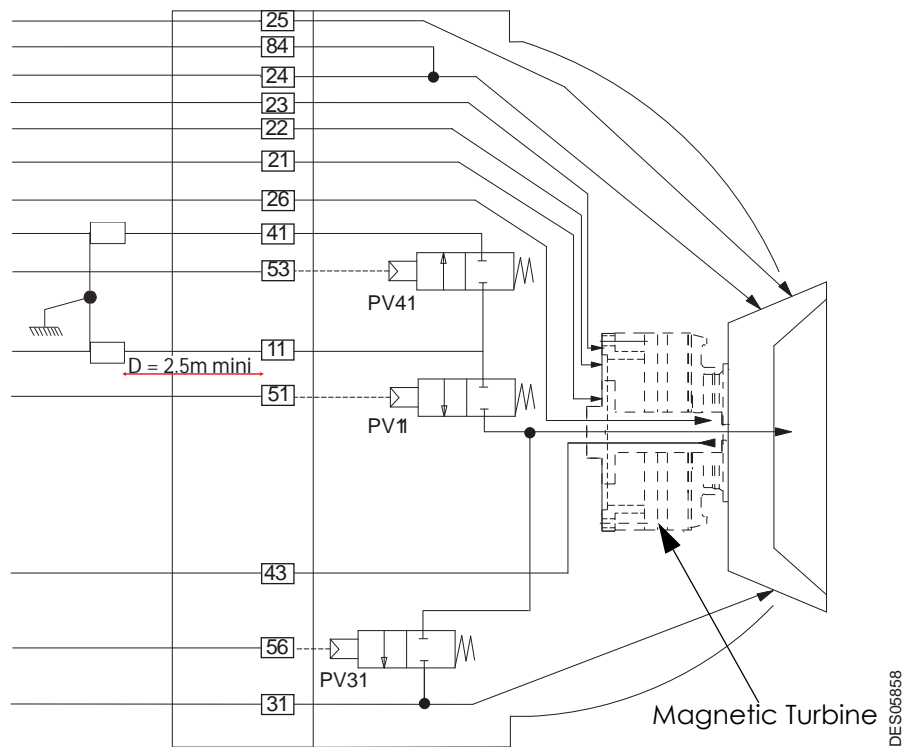

Item	Function	Hose Characteristics
11	Paint supply	D: 5/ 8 PTFE
21	Turbine rotation	D: 7/ 10 polyurethane
22	Turbine braking	D: 6/ 8 polyurethane
23	Bearing air	D: 4/ 6 polyurethane
24	Shaping air 1	D: 7/ 10 polyurethane
25	Shaping air 2	D: 7/ 10 polyurethane
26	Microphone air IN	D: 4/ 6 polyurethane
31	Injector and Bell cup exterior rinsing air/solvent	D: 4/6 PTFE
41	Dump	D: 5/ 8 PTFE
43	Microphone return (OUT)	D: 4/ 6 polyurethane
51	Pilot of paint supply	D: 2.7/ 4 polyurethane
53	Dump pilot	D: 2.7/ 4 polyurethane
56	Injector and Bell cup exterior rinsing air/solvent pilot	D: 2.7/ 4 polyurethane
84	Remote 24-shaping air	D: 2.7/ 4 polyurethane

PTFE hoses should be replaced neither by polyamide hoses nor by polyurethane hoses.
 Blue hoses are used for the different air supplies.
 The colourless hoses are used for the product.



WARNING : After a phase of the exterior bell cup and injector, it is imperative to finish the rinsing phase by a blowing of the "31" hose during 1 to 2 seconds.
 The 41-hose (dump) must, for its part, be cleaned and blown during 1 to 2 seconds before switching on high voltage.

5. Startup

5.1. Tools

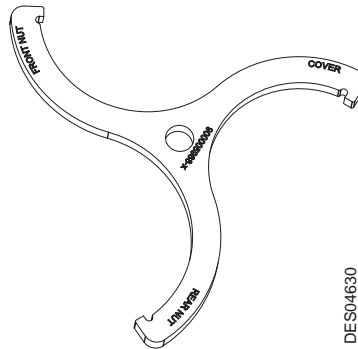

Part Number	Description	Qty	Sale unit
900005988	Installation / Removal tool for outer cover, rear and front nuts	1	1

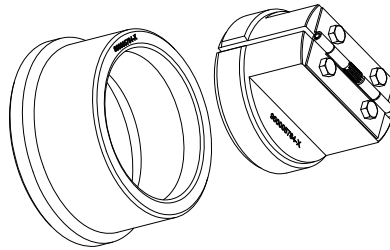

Part Number	Description	Qty	Unit of sale
900005784	Removal tool for EC 35 magnetic bell cup	1	1

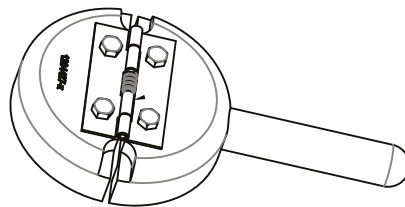

Part Number	Description	Qty	Sale unit
900000803	Removal tool for EC 50 magnetic bell cup	1	1
1204427	Removal tool for EX 65 magnetic bell cup	1	1

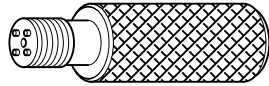

DES00039

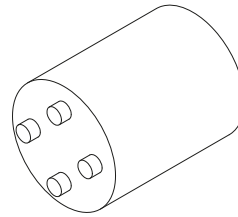

DES01673

Part Number	Description	Qty	Sale unit
1303689	Removal tool for microvalve	1	1
1403478	Automatic tightening tool for microvalve	1	1

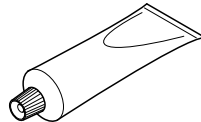

DES00685

Part Number	Description	Qty	Sale unit
H1GMIN017	White vaseline (100 ml)	1	1
H1GSYN037	Dielectric grease for high voltage unit (100 ml)	1	1

Additional tools and accessories required:

The tool listed below should be available for product installation and maintenance operations.

- Hose cutter (P/N.: W3SCTU002).
- Screwdriver (small and medium).
- Allen wrench (2.5 mm).
- Flat wrenches (4, 6, 14 and 18 mm)
- Open-socket wrench (6 mm)
- Fine brush.

5.2. Installation

For installation rules: [see § 1.4.2 page 11](#)

- **Step 1:** Install the robotic adapter specific to the robot to be equipped.
- **Step 2:** Cross the strand (low voltage cable and hoses) through the robot wrist.
- **Step 3:** Screw the atomizer via its equipped support on the robotic adapter.
- **Step 4:** Connect 11 and 41 hoses to the grounding kit to a distance from 2.5m minimum.

5.3. Shutdown and Startup Procedures

Important recommendations

Follow the air settings given in Section 3.2.

The rotor and stator will become unusable if the bearing air is cut.

The bearing air must be at least 6 bar at the inlet of the body.

(*For hose lengths greater than 4.5 m, measure the air pressure at the quick-disconnect plate to determine the correct setting).

Check that the speed regulating module transmits a signal.

5.3.1. Shutdown Procedure

Important steps to be observed:

		Step 1	Step 2	Step 3	Step 4	Step 5	Step 6
Stop atomizing	Sequence chart						
Switch off the high voltage power supply							
Run a rinsing cycle							
Run a blowing cycle of paint and solvent hoses							
Cut off the shaping air							
Cut off the turbine rotation air *							
Cut off the bearing air air							



WARNING : * Wait until the turbine has completely stopped 0 rpm.

5.3.2. Startup Procedure

Important steps to be observed:

		Step 1	Step 2	Step 3	Step 4
Switch on the bearing air supply	Sequence chart				
Start up turbine rotation					
Switch on the shaping air supply					
Switch on the high voltage supply					
Start up atomization					

6. Maintenance

6.1. Summary table of maintenance operations

Procedure	Description	Preventive	Corrective	Duration	Frequency	
A	Cleaning of atomizer exterior, outer cover and bell cup	X		5 min.	8H	
B	B1	Cleaning of bell cup	X	2 min.	40H	
	B2	Cleaning of outer cover	X	8 min.	40H	
	B3	Cleaning of injector / injector holder	X	4 min.	40H	
	Body maintenance					
C	C1	Body installation / removal		X	5 min.	
	C2	Replacement of turbine		X	5 min.	> 10000 H
	C3	Replacement of solvent pipette		X	5 min.	> 10000 H
	C4	Replacement of microvalves		X	5 min.	2.5 millions cycles
	C5	Replacement of o-rings		X	15 min.	> 10000 H
	C6	Replacement of fittings		X	60 min.	> 10000 H
	C7	Replacement of high voltage unit		X	60 min.	> 10000 H
	C8	Replacement of hoses /low voltage cable (see RT Nr 7068) wiring		X	60 min.	2000 H

6.2. Preventive maintenance

These maintenance operations can be performed online. Always refer to the health and safety instructions before carrying out any work ([see § 1.4 page 6](#)).

6.2.1. Procedure A: Atomizer exterior

At regular intervals during frequent use, and at the end of each cycle:

- Stop atomization, switch off the high voltage supply, (ensure that the GNM 200 control module does not deliver high voltage) and run a rinsing cycle.
- Stop the turbine.



WARNING : Always wear safety goggles.

Whenever solvent is handled, gloves made of an appropriate resistant material must be worn. Work in a well-ventilated area whenever solvent is used.



WARNING : Prior to cleaning, It is essential to eliminate all electrostatic charges on the atomizer using a cloth soaked with water then clean using a rag and an approved cleaning product. Do not use a manual solvent gun.



WARNING : Under no circumstances must the atomizer or any of its components be sprayed with solvent or water at high or low pressure.



WARNING : Soak the body of the atomizer in a liquid of cleaning without integral disassembling of all its components is strictly prohibited. It is essential to remove bell cup, shaping air assembly, turbine, la turbine, microvalves, o-rings and fittings by using suitable tools ([see § 5.1 page 29](#)) then dry all the parts perfectly.

If this information is not respected, there is a risk of total deterioration of the atomizer imposing its replacement which is not covered by the SAMES KREMLIN guarantee. It is in the same way strictly prohibited to soak the turbine in solvent.



WARNING : SAMES KREMLIN advises the use of anti-static plastic films to protect bodies and insulating covers of the atomizers. These films are conductive and can short-circuit the high voltage.

SAMES KREMLIN forbids the use of adhesives on the insulating parts of the atomizers. The glue of the adhesives is conductive and thus can short-circuit the high voltage.

SAMES KREMLIN also forbids the use of absorbent textile cover to protect bodies and insulating covers of atomizers. Textile covers retain the cleaning products and paint what can generate problems of high voltage (drilling, ionization, degradation of the material...).

Thus, SAMES KREMLIN recommends the use of insulating grease for protection of the atomizers. In any case, insulating protection means must be used to prevent the slightest risk of current overconsumption.

This is why, insulating protection means must be renewed on a regular basis.

1	Bell cup
2	Outer cover
3	Grooves in outer cover

- Clean the atomizer, the outer cover and the bellcup exterior using a clean rag.
- Check that the outer cover grooves are clean.
- Dry carefully with compressed air.

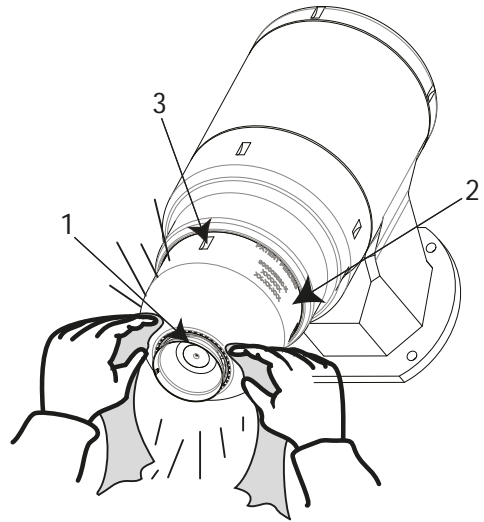

DES06021

6.2.2. Procedure B1: Magnetic bell cup



WARNING : All bell cup maintenance or handling operations must be performed with extreme care, since the bell cup is balanced.



WARNING : Stop the turbine and cut off the shaping air supply, the bearing air remains pressurized.

- Remove the magnetic bell cup using the suitable tool, [see RT Nr 7071](#).
- Carry out a visual inspection.
- Let the bell cup soak for one hour in an appropriate solvent, then clean with a clean cloth and soft brush.



WARNING : Make sure that all surfaces are clean and free from impurities. Take care particularly of the internal and external surfaces of the cylinder of the bellcup fixing.

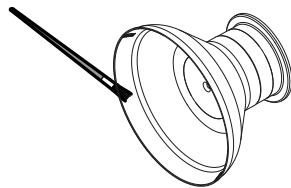
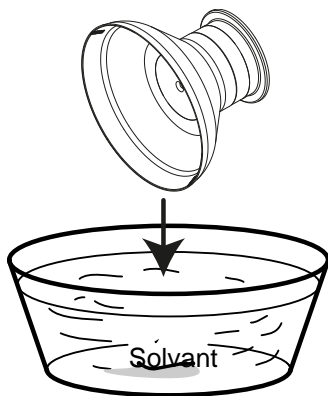

- Dry carefully with compressed air.

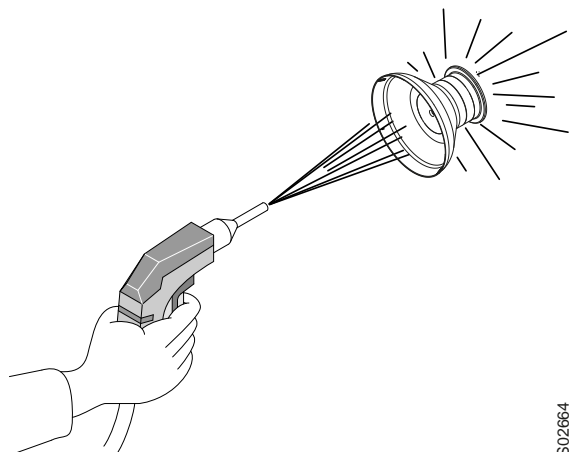

- Reinstall the bell cup on the atomizer.

6.2.3. Procedure B2: Shaping air assembly

- The bell cup has been previously removed,
- Begin to loosen the outer cover with tool (P/N: 900005988), then continue manually.
- Remove the outer cover, then the shaping air shroud.
- Carry out a visual inspection of the three components (jouter cover, shaping air shroud and o-ring) replace if necessary, then clean the outer cover:

- **Step 1:** Let the outer cover soak for one hour in an appropriate solvent then clean the outer and inner surfaces with a clean cloth soaked in solvent.

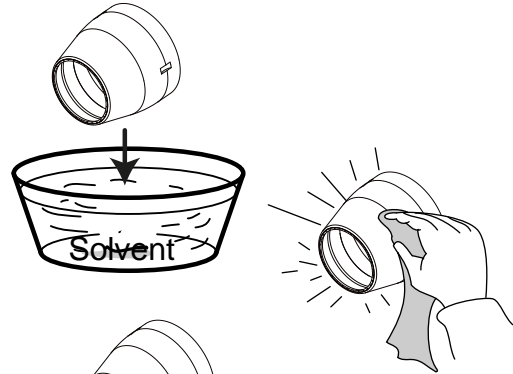

- **Step 2:** Use a nylon brush to clean the holes on the front face of the outer cover.

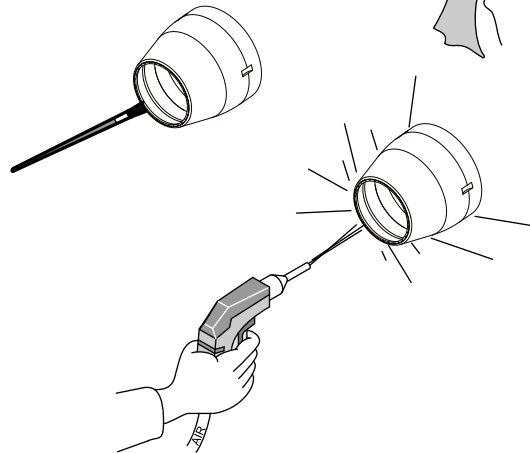

- **Step 3:** Dry carefully with compressed air (concentrating on the holes to eliminate paint residues) then wipe with a clean, dry cloth.

- Check the condition of the inner shaping air shroud and, if necessary, clean it with a cloth soaked in solvent.

- Reinstall the shaping air assembly, [see RT Nr 7071](#).



WARNING : Keep the threading between the outer cover and the body clean. It is imperative to coat the threading with vaseline to facilitate the reinstallation of the outer cover.

DES03336

6.2.4. Procedure B3: Injector / Injector holder assembly

- Bell cup, shaping air assembly, and turbine has been previously removed,

- **Step 1:** Using a 4mm-flat wrench, unscrew the injector (in the clockwise direction) and remove it, taking care not to damage the injector and its o-rings.



- **Step 2:** Leave to soak for one hour in a suitable solvent, then dry carefully with compressed air. Check the o-rings, replace if necessary.
- **Step 3:** Place the injector onto the injector holder and tighten by turning clockwise to a maximum torque of 3.5 Nm.

- **Step 4:** If necessary, remove the injector holder, Untighten the 3 screws securing the injector holder using the 2.5 mm allen key. For re-assembling, tighten the screws to a maximum torque of 1,7 N.m.



3 - C M 3x10
screws

6.3. Corrective maintenance

The following operations are preferably performed in a workshop.

6.3.1. Procedure C1: Body installation / removal

- **For Nanobell II full wrist version:** unscrew the straight connector, loosen the cover using the tool (P/N# 900005988) and slide it on the hoses.
For Nanobell II hollow wrist: Slide back the part fastening low voltage cable and hoses in order to separate the body from the support.
- **For the two versions of Nanobell II:**
 - Remove bell cup, shaping air assembly (and if necessary turbine and the injector / injector holder assembly).

- Unscrew the front nut using tool (P/N 900005988).



- Unscrew the securing pin.

Securing pin



- Separate the body from the support.
- Disconnect the hoses one by one
- Loosen the fastening screw of the high voltage unit. Withdraw the high voltage unit ([see § 6.3.7 page 41](#)).
- **Reinstall the body:** Proceed in reverse order.



6.3.2. Procedure C2: Replacement of turbine

- **Remove the turbine:**
Loosen the five screws fixing the turbine on the body using a 2.5mm- allen wrench. Pull the turbine along the axis.



5 - CHc M 3 x 10 screws

- **Install the turbine:**
Install and secure the turbine on the body with the five screws (tightening torque: 1,5Nm).

6.3.3. Procedure C3: Replacement of solvent pipette

- **Remove the solvent pipette:**

Unscrew the solvent pipette using a 4mm-flat wrench.

Change systematically the o-ring (P/N J3STKL027) located in bottom of the pipette housing. Remove it using a small hook then push a new o-ring in the pipette housing using an allen wrench.



Replace and screw the new pipette in the body. The pipette shoulder must slightly be placed into the body.

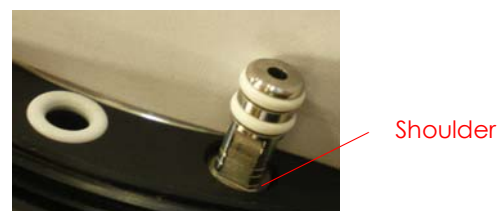

Nota: Check the condition of the o-rings on the solvent pipette each time the outer cover is removed.

6.3.4. Procedure C4: Replacement of microvalves

- Unscrew the front nut using tool (P/N: 900005988).



- Slide the front nut to be able to have access to the microvalves. Unscrew the securing pin.



- **Remove the microvalves:**

[see RT Nr 6021](#) for the operations listed below.

Remove the microvalves using tool (P/N 1303689).

Check the condition of the microvalves, clean them and replace if necessary.

Before re-assembling, coat the threading of the microvalves with vaseline grease.



6.3.5. Procedure C5: Replacement of body o-rings

- Check the conditions of the o-rings and replace if necessary.
O-ring kit (turbine side): 1527518.
Prior to reinstalling the body, make sure all the o-rings are present.



6.3.6. Procedure C6: Replacement of fittings

- To access to the fittings [see § 6.3.1 page 38](#).
- Loosen the fitting nut(s) to be replaced using a suitable flat wrench, disconnect the hose(s).
- Loosen the fitting(s) and withdraw from the body.

- To merely replace the fitting, cut the hose approximately 20 mm from its end using the tube cutter (P/N W3SCTU002). Caution: the cutting plane must be perfectly perpendicular to the hose.



Reinstallation of fittings:

- Place PTFE tape on fitting threading, then screw each fitting into the body using a 14 or 18mm- flat wrench according to the diameter.



PTFE tape

- Push the hose into the fitting and tighten the nut on the hose.

6.3.7. Procedure C7: Replacement of high-voltage unit

- To access to the high voltage unit [see § 6.3.1 page 38](#)

- To withdraw high-voltage unit UHT 158, loosen the fastening screw in order to separate the body from the support.



Securing pin

- Slide the body. Unscrew the fastening screw of the HVU and pull the high-voltage unit along the axis.

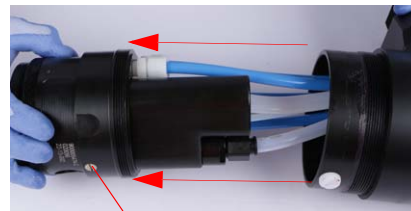

Fastening screw of UHT 158



- **Install the new HVU:** Coat the high voltage well (body side and HVU side) with red dielectric grease. Screw the securing device. Install the insulator, then tighten with a 6mm- open-socket wrench by positioning it on the dishes of the banana plug. Push the high voltage unit in all the way and fasten the fastening screw. Connect the low voltage cable ([see RT Nr 7068](#) for the connecting diagram). Connect the ground wire to the securing device.

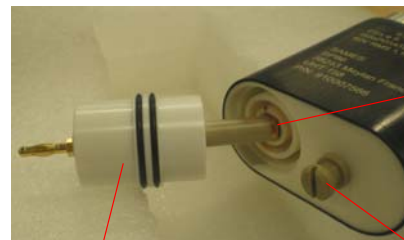

Insulator

High voltage well

Securing device UHT 158

7. Spare parts list

7.1. Nanobell II hollow wrist

Bell cup and shaping air assemblies are not included.

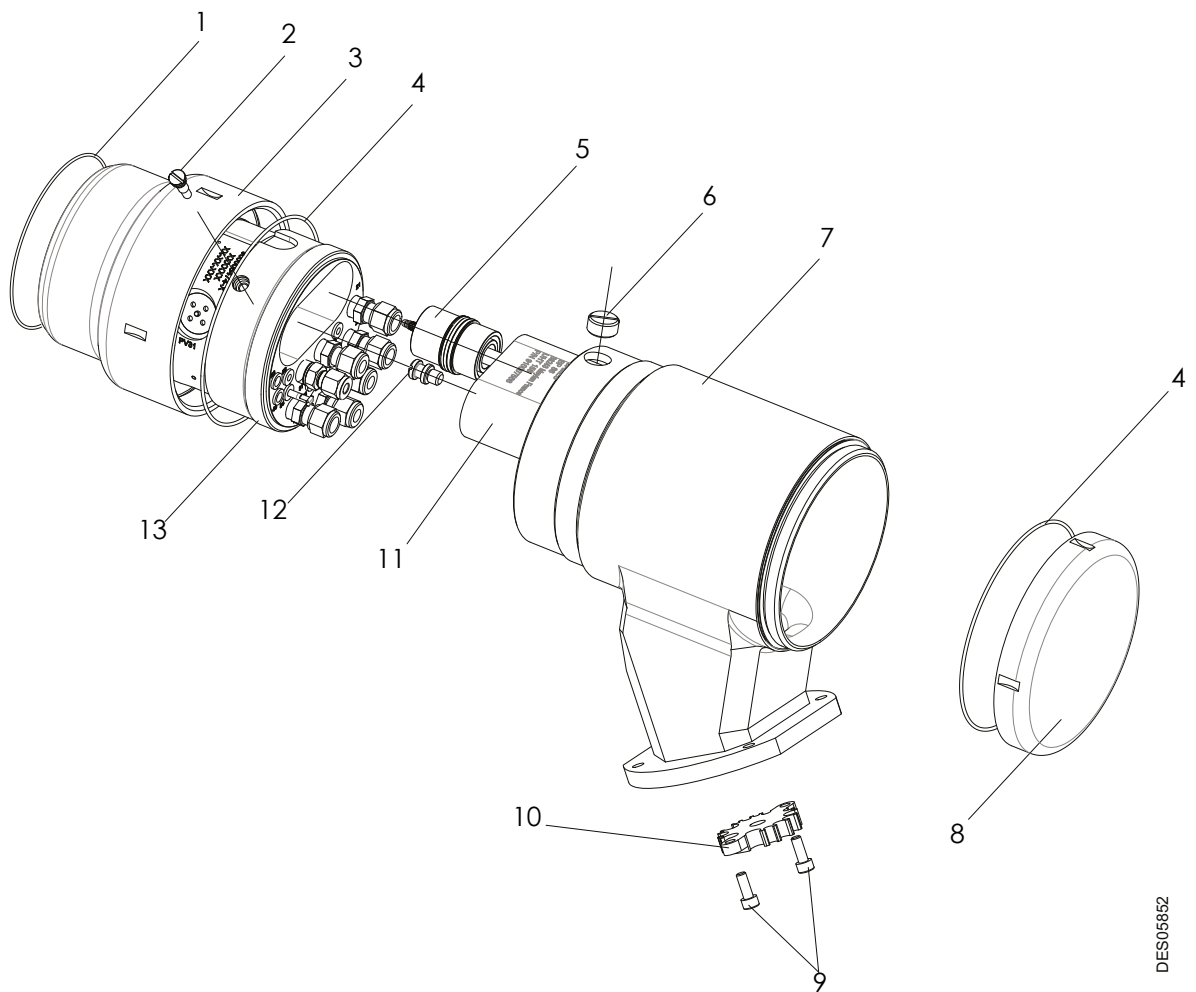

DES05852

Item	Part number	Description	Qty	Unit of sale	Maintenance level for spare part (*)
	910016011	Nanobell II hollow wrist	1	1	3
1	J2FENV654	O-ring - FEP-FKM	1	1	1
2	910008218	Fastening screw of high voltage unit	1	1	1
3	900010746	Nanobell II front nut	1	1	3
4	160000026	O-ring FEP-FKM	2	1	1
5	910007405	High voltage insulator	1	1	3
6	900010748	Securing pin	1	1	3
7	910019345	Nanobell II support	1	1	3
8	900010734	Nanobell II cover	1	1	3
9	X9SVCB223	Glass fiber nylon C M 6 x 16 screw	2	1	1
10	900011060	Cable and Hoses support plate	1	1	3
11	910007566	High voltage unit UHT 158 (see RT Nr 7068)	1	1	3
12	900005491	Securing device of high voltage unit	1	1	3
13	910008553	Body assembly (see § 7.3 page 46)	1	1	3
Not shown					
-	910016346	Hoses / Low voltage cable wiring	1	1	2
-	910003399	Grounding kit (see § 7.6 page 53)	1	1	-
	910018929	Kit to transform a Nanobell II hollow wrist version to a full wrist version	1	1	-

(*)

Level 1: Standard preventive maintenance

Level 2: Corrective maintenance

Level 3: Exceptional maintenance

7.2. Nanobell II full wrist

Bell cup and shaping air assemblies are not included.

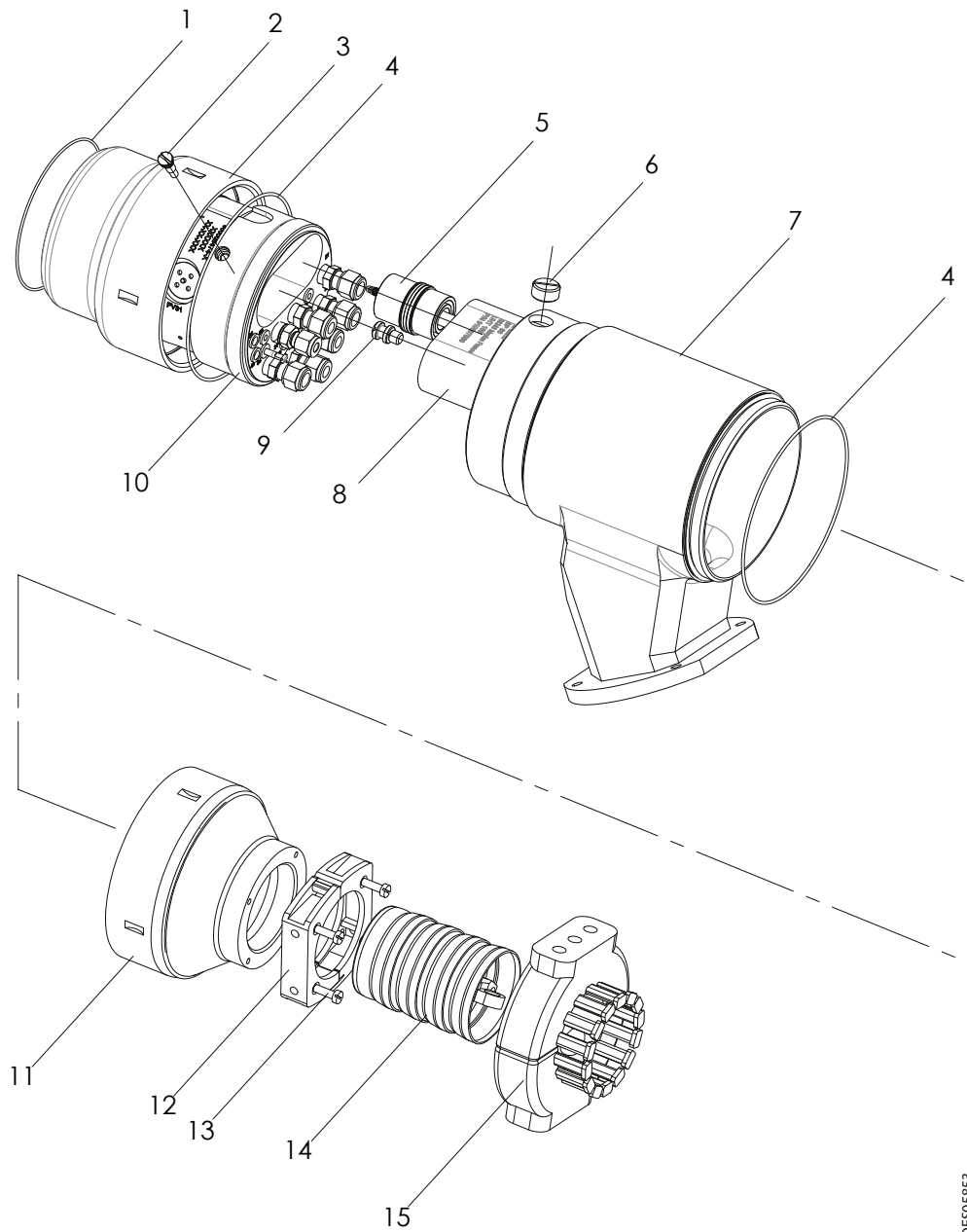

Item	Part number	Description	Qty	Unit of sale	Maintenance level for spare part (*)
	910016012	Nanobell II full wrist	1	1	3
1	J2FENV654	O-ring FEP-FKM	1	1	1
2	910008218	Fastening screw of high voltage unit	1	1	1
3	900010746	Nanobell II front nut	1	1	3
4	160000026	O-ring FEP-FKM	2	1	1
5	910007405	High voltage insulator	1	1	3
6	900010748	Securing pin	1	1	3
7	910019345	Nanobell II support	1	1	3
8	910007566	High voltage unit UHT 158 (see RT Nr 7068)	1	1	3
9	900005491	Securing device of high voltage unit	1	1	3
10	910008553	Body assembly (see § 7.3 page 46)	1	1	3
11	900013445	Nanobell II cover	1	1	3
12	110002005	Chain adapter	1	1	3
13	X9SVCB183	C M5 X 16 glass fiber nylon	4	1	1
14	110001995	Chain	150	link	3
15	110001638	Fixation of chain	1	1	3
Not shown					
-	910016346	Hoses / Low voltage cable wiring	1	1	2
-	910003399	Grounding kit (see § 7.6 page 53)	1	1	-
	910018930	Kit to transform a Nanobell II full wrist version to a hollow wrist version	1	1	-

(*)

Level 1: Standard preventive maintenance

Level 2: Corrective maintenance

Level 3: Exceptional maintenance

7.3. Body assembly

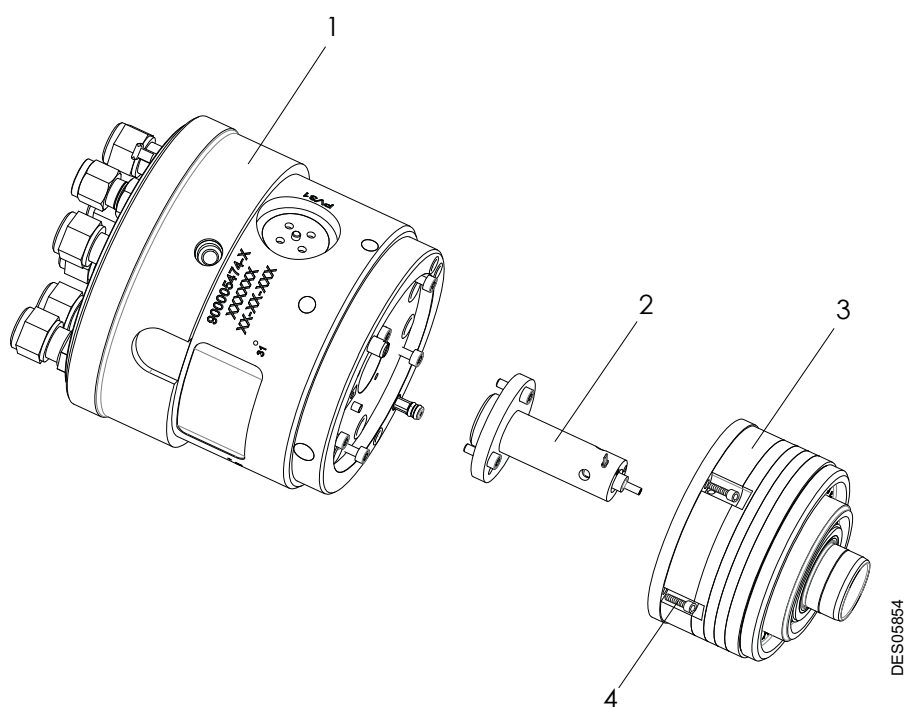

Item	Part number	Description	Qty	Unit of sale	Maintenance level for spare part (*)
	910008553	Body assembly	1	1	3
1	910007461	Equipped body (see § 7.3.1 page 47)	1	1	3
2	910001130	Injector / Injector holder assembly (see § 7.4 page 50)	1	1	3
3	1525802	S12 magnetic air bearing turbine type BTM (see RT Nr 6350)	1	1	3
4	X4FVSY067	Screw Chc M 3 x 10 ss 316	5	1	3

(*)

Niveau 1: Maintenance préventive

Niveau 2: Maintenance corrective

Niveau 3: Maintenance exceptionnelle

7.3.1. Equipped body

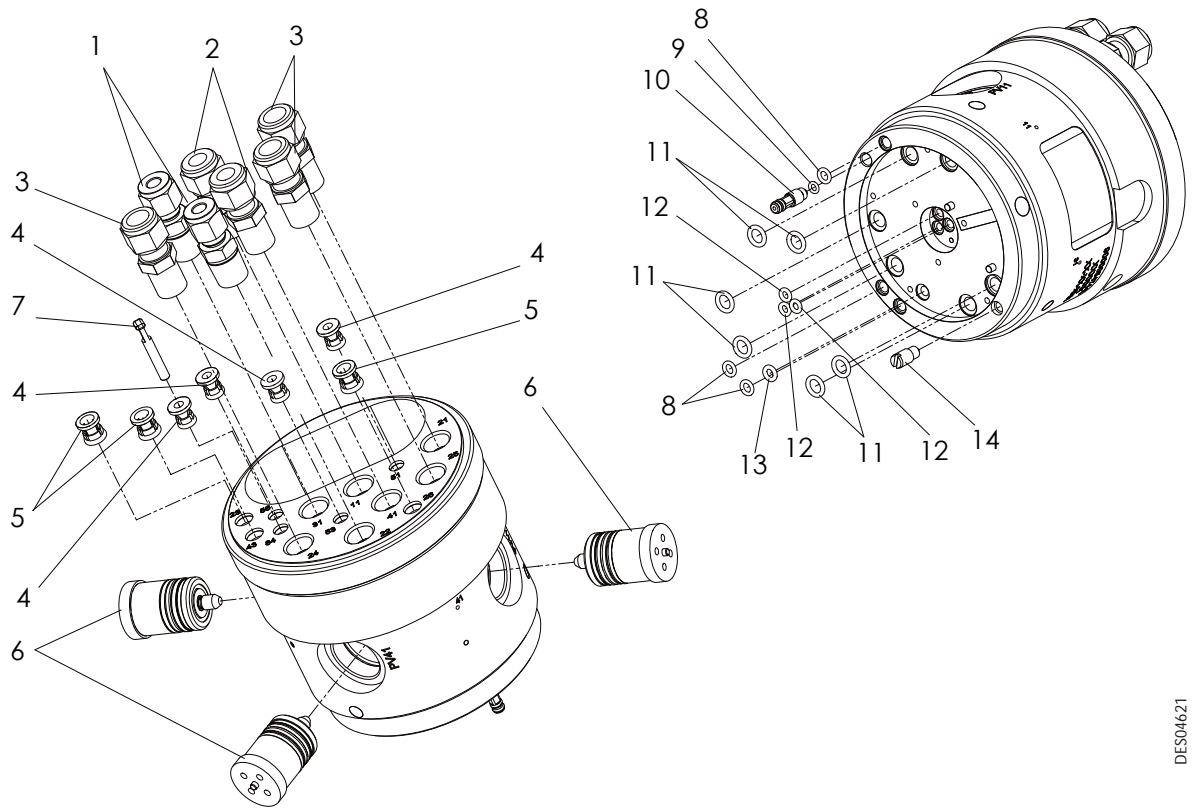

DES04621

Item	Part number	Description	Qty	Unit of sale	Maintenance level for spare part (*)
	910007461	Equipped body	1	1	3
1	F6RPUQ092	Male fitting D: 6 1/4G	1	1	1
2	F6RPUQ093	Male fitting D: 8 1/4G	3	1	1
3	F6RPUQ094	Male fitting D: 10 1/4G	3	1	1
4	F6RXZG081	Stainless steel grip and seal	4	1	2
5	F6RXZG082	Stainless steel grip and seal	3	1	2
6	1507375	Microvalve, 2 ways, orange indicator with chemically inert o-rings (see RT Nr 6021)	3	1	1
	910010850	Microvalve with bellow (**) (see RT Nr 6422)	3 option	1	1
7	F6RLZX398	Quick release plug	1	1	3
8	J3STKL039	O-ring - chemically inert	3	1	1
9	J3STKL027	O-ring - chemically inert	1	1	1
10	910008194	Solvent pipette	1	1	1
	J3STKL027	O-ring - chemically inert	2	1	1
11	J2FTDF075	O-ring - viton	6	1	1
12	J3STKL002	O-ring - chemically inert	3	1	1
13	J2FTDF035	O-ring - viton	1	1	1
14	1402691	Shaping air alignment pin	1	1	3

(*)

Level 1: Standard preventive maintenance

Level 2: Corrective maintenance

Level 3: Exceptional maintenance

Remarks: (**) If the microvalves are regularly blocked , replace the microvalve (P/N # 1507375) by a microvalve with bellow (P/N # 910010850).

O-ring set

Item	Part number	Description	Qty	Unit of sale	Maintenance level for spare part (*)
	1527518	O-ring set (turbine side)	1	1	1
8	J3STKL039	O-ring - chemically inert	3	1	1
11	J2FTDF075	O-ring - viton	6	1	1
12	J3STKL002	O-ring - chemically inert	3	1	1
13	J2FTDF035	O-ring - viton	1	1	1

Fitting set

Item	Part number	Description	Qty	Unit of sale	Maintenance level for spare part (*)
	910004632	Fitting set	1	1	1
1	F6RPUQ092	Male fitting D: 6 1/4G	1	1	1
2	F6RPUQ093	Male fitting D: 8 1/4G	3	1	1
3	F6RPUQ094	Male fitting D: 10 1/4G	3	1	1
4	F6RXZG081	Stainless steel grip and seal	4	1	2
5	F6RXZG082	Stainless steel grip and seal	3	1	2
7	F6RLZX398	Quick release plug	1	1	3

Location of fittings

Item	Location
1	on 31
2	on 11, 22 and 41
3	on 21, 24 and 25
4	on 51, 53, 56 and 84
5	on 23, 26 and 43
7	on 84

84: plug-in the shaping air pressure,

A plug is placed by default otherwise install a 2.7/4 hose to be able to measure the shaping air pressure: diagrams [see § 4 page 28](#)).

7.4. Injector / injector holder

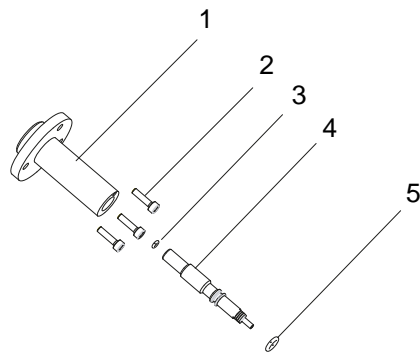

DES02117

Item	Part number	Description	Qty	Unit of sale	Maintenance level for spare part (*)
	910001130	Injector / injector holder assembly	1	1	3
1	738354	Injector holder	1	1	3
2	X4FVSY067	Screw C M 3 x 10 - stainless steel	3	1	1
3	J3STKL014	O-ring - chemically inert	1	1	1
4	738635	Injector Dia: 1.8	1	1	1
5	J3STKL005	O-ring - chemically inert	1	1	1

(*)

Level 1: Standard preventive maintenance

Level 2: Corrective maintenance

Level 3: Exceptional maintenance

7.5. Robot adapters

7.5.1. Adapter for Motoman EXP 2050 and 2900 robots

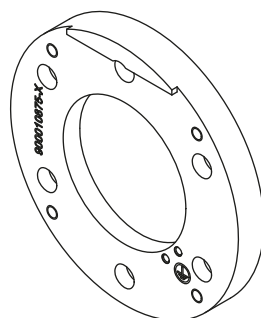

DES05862

Part number	Description	Qty	Unit of sale	Maintenance level for spare part (*)
910018263	Robot adapter	1	1	-

7.5.2. Adapter for Fanuc P250 robot

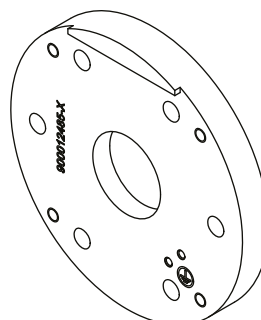

DES06112

Part number	Description	Qty	Unit of sale	Maintenance level for spare part (*)
910019313	Robot adapter	1	1	-

7.5.3. Adapter for Staubli RX 160 robot

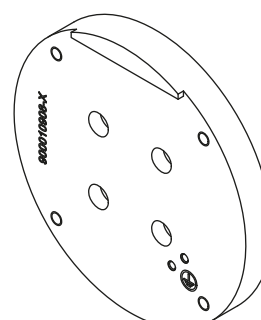

DES05861

Part number	Description	Qty	Unit of sale	Maintenance level for spare part (*)
910018262	Robot adapter	1	1	-

7.5.4. Adapter for Staubli TX 250 robot

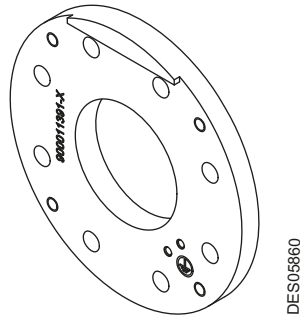

Part number	Description	Qty	Unit of sale	Maintenance level for spare part (*)
910018264	Robot adapter	1	1	-

7.5.5. Adapter for ABB IRB 4400 robot

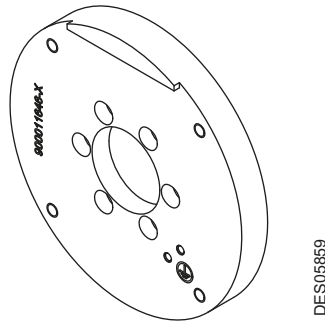

Part number	Description	Qty	Unit of sale	Maintenance level for spare part (*)
910018261	Robot adapter	1	1	-

Remarks: For other robots: contact SAMES KREMLIN.

7.6. Grounding kit

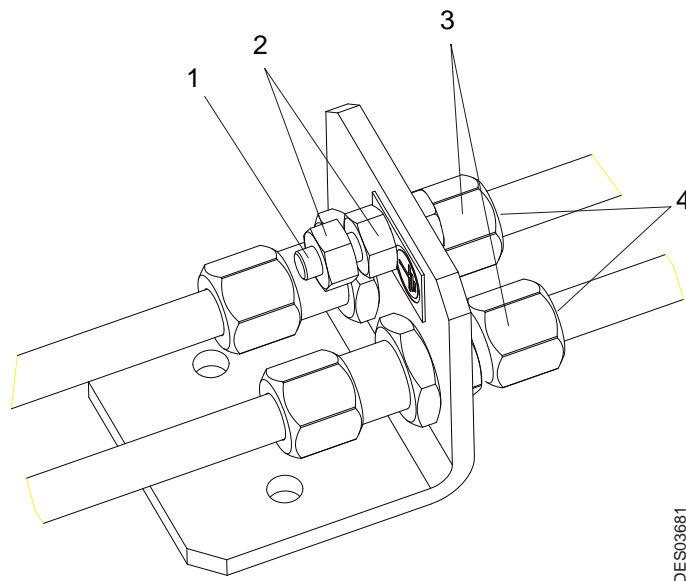

DES03681

Item	Part number	Description	Qty	Unit of sale	Maintenance level for spare part (*)
	910003399	Grounding kit	1	1	-
1	X7CVHA226	H M6 x 20 brass screw	1	1	-
2	X7CEHU006	H M 6 brass nut	2	1	-
3	F6RXGQ056	Bulkhead union	2	1	-
4	F6RXZX061	Stainless steel sheath	4	1	-

8. Option Nanobell II, Gun spraying head version

8.1. Characteristics

8.1.1. Dimensions

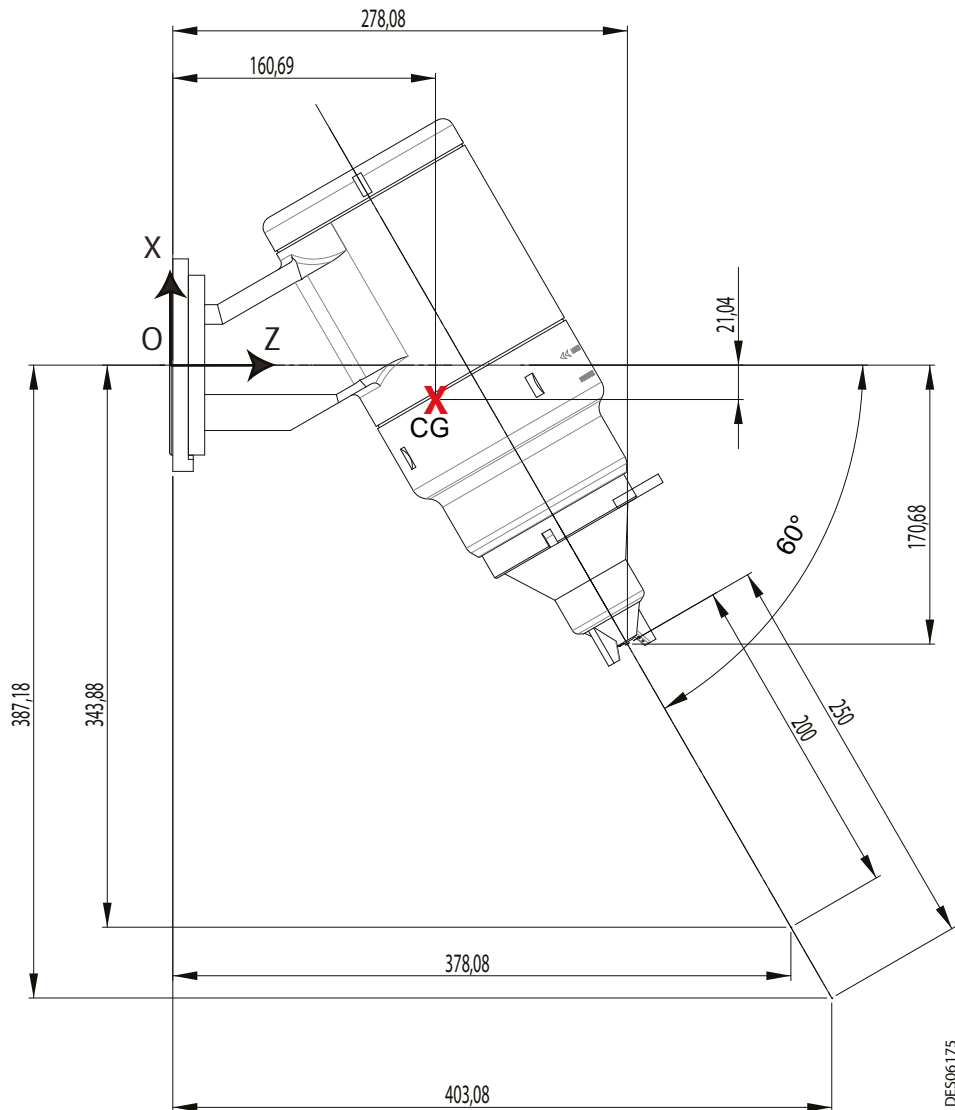

Note:

Weight : 4.2 kg

Gravity center (CG) in millimeters

X = -21.04 ; Y = -0.49; Z = 160.69

Main inertia axis (mm) and moments (kg x mm²), measured to the gravity center:

lx = (-0.51, -0.00, 0.86)	Px = 14816.98
ly = (-0.86, 0.03, -0.51)	Py = 37438.07
lz = (-0.03, -1.00, -0.01)	Pz = 43863.40

Inertia moments (kg x mm²), measured to the output C.S:

lxx = 139793.34	lxy = -177.53	lxz = -24170.17
lyx = -177.53	lyy = 154058.21	lyz = -347.07
lzx = -24170.17	lzy = -347.07	lzz = 22671.49

8.2. Fluid diagram

Cross-references between Bell cup version and Gun version

Marking no.	Bell cup version	Gun version
11	Paint supply	Paint supply
21	Turbine drive	Atomizing air
22	Turbine brake	Not used
23	Bearing air	Not used
24	Shaping air 1	Fan air 1
25	Shaping air 2	Fan air 2
26	Microphone air IN	Not used
31	Injector and Bell cup exterior rinsing air/sol-	Not used
41	Dump	Dump
43	Microphone return OUT	Not used
51	Pilot of paint supply	Pilot of paint supply
53	Dump pilot	Dump pilot
56	Injector and Bell cup exterior rinsing air/sol-vent pilot	Not used
84	Remote 24-shaping air	Not used

Remarks: It is advised to seal the fittings not used, without removing them with an appropriate cap.

8.3. Tools

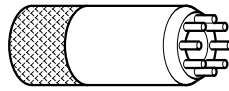

DES00557

P/N	Description	Qty	Unit of sale
643156	Installation / Removal tool of nozzle	1	1

8.4. Procedure to transform a Nanobell II bell cup version, to a Nanobell II Gun version

- Carry out a shutdown procedure([see § 5.3.1 page 31](#)).

- Remove the bell cup with the suitable tool.



- Loosen the shaping air assembly using tool (P/N # 900005988) and remove it.

- **Remove the turbine:**
Loosen the five screws fixing the turbine on the body using a 2.5mm- Allen wrench. Pull the turbine along the axis.

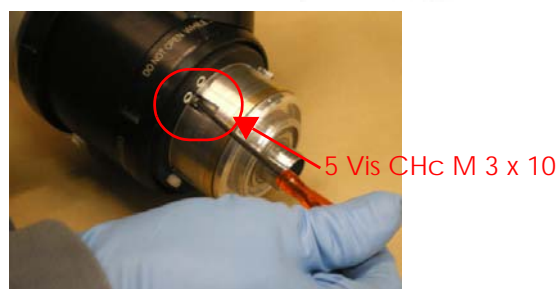

- Loosen the three screws (M3 x 8) fixing the injector holder using a 4.5mm- Allen wrench. Remove it.



- Unscrew the solvent pipette using a 4mm- flat wrench as well as the alignment pin.

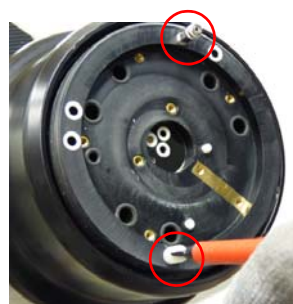

- Place the equipotential plate on the atomizer by aligning the pin and the plate. Screw the plate using the eight screws (3 screws M 3x8 on the center and 5 screws on the circumference).

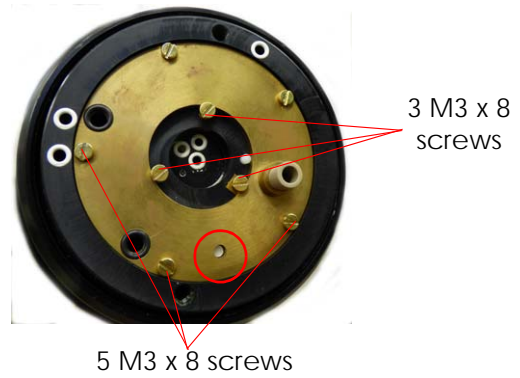

- Install the Gun spraying head on the plate by aligning the spring and the HV contact screw by having beforehand coating the spring as well as the contact screw with dielectric grease.

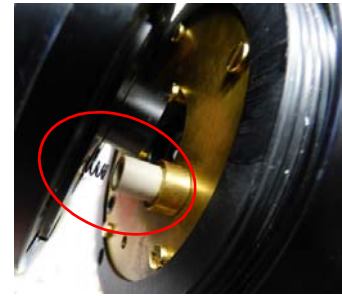

- Put in place the Gun spraying head on the atomizer, screw



and lock the Gun fastening nut using the tool (P/N # 900005988).



8.5. Maintenance



WARNING : This paragraph is only intended for the gun spraying head, for the complete maintenance of the atomizer [see § 6 page 32](#).

8.5.1. Summary table of maintenance operations

Procedure	Description	Preventive	Corrective	Duration	Frequency
A	Cleaning of atomizer exterior	X		5 mn	8H
B	Cleaning of cap	X		5 mn	8H
C	Maintenance of Gun spraying head				
	C1 Gun spraying head replacement		X	5 mn	> 10000 H

8.5.2. Preventive maintenance

8.5.2.1. Procedure A

- Clean the atomizer with a clean cloth.
- Check that the holes on the cap are clean.
- Dry carefully using compressed air.



DES06176

8.5.2.2. Procedure B

- Remove the cap.
- Leave it to soak in solvent then clean it with a clean cloth and a soft brush.
- Dry carefully using compressed air.



WARNING : The flat air spray caps must be replaced daily with clean flat air spray caps.

8.5.3. Maintenance corrective

8.5.3.1. Procedure C1: Gun spraying head

Disassembly:

- Unscrew the fastening nut of the Gun spraying head using the tool (P/N # 900005988).



- Manually unscrew the cap nut.

- Remove the cap.



- Remove the swivel ring.

- Using the tool (P/N # 643176), unscrew the nozzle.



- If necessary, remove the equipotential plate by unscrewing the eight M3x8 screws.

Reassembly:

- Check the different components, replace if necessary ([see § 8.6 page 61](#)).
- Put back in place the equipotential plate by aligning the hole in the plate and the alignment pin located on the body and tighten the 8 M3 x8 screws.
Clean the contact screw with a clean and not fluffy cloth and coat it with dielectric grease.



- Install new o-rings on the Gun head adaptation. Check that the spring is in place on the back of the head and coat it with dielectric grease.

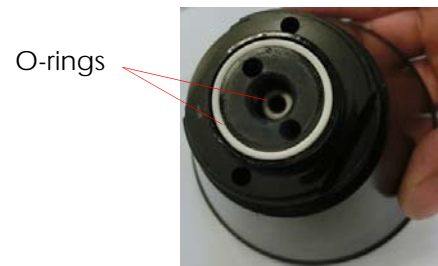

- Put in place the nozzle using the tool P/N # 643176. Make sure not to damage the nozzle injector.
- Install the swivel ring.
- Install the cap.
- Screw the cap nut.
- Install the gun spraying head on the atomizer.
- Secure the fastening nut of the Gun spraying head using the tool (P/N # 900005988).

8.6. Spare parts for the Gun spraying head

8.6.1. Head

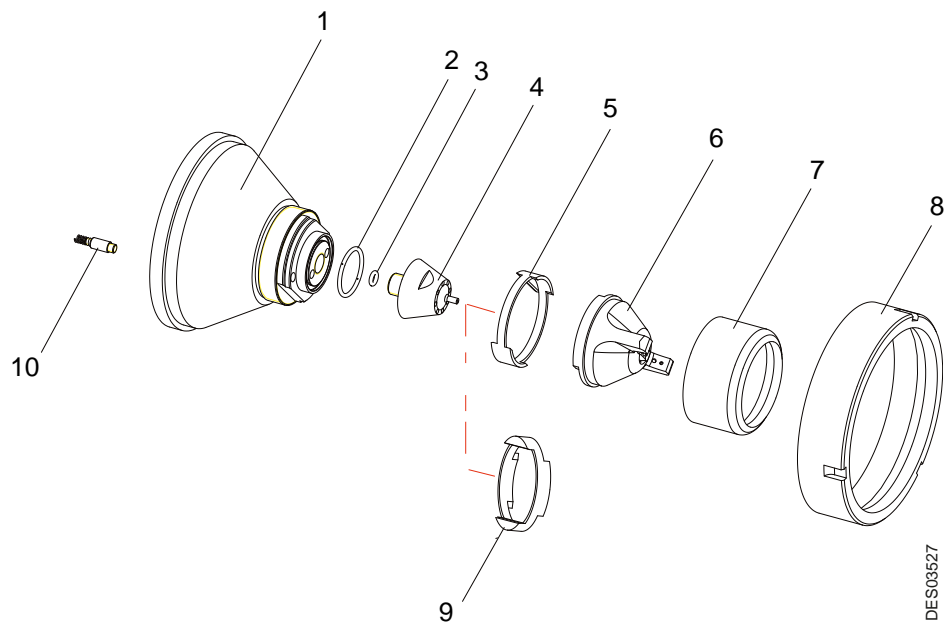

Item	P/N	Description	Qty	Unit of sale	Maintenance level for spare part (*)
	910019815	Gun spraying head	1	1	3
1	-	Gun spraying head adaptation	1	-	-
2	J2FTDF258	O-ring - chemically inert	1	1	1
3	J3STKL035	O-ring - chemically inert	1	1	1
4	1311405	Nozzle D:1,2	1	1	1
5	1311778	Vertical spray swivel ring	1	1	3
6	428376	Fan air spray cap - brass	1	1	2
7	1408174	Nut of fan air spray cap	1	1	1
8	1310289	Gun fastening nut	1	1	2
9	1311777	Horizontal spray swivel ring	1	1	3
10	910000216	HV contact screw	1	1	1

(*)

Level 1: Standard preventive maintenance

Level 2: Corrective maintenance

Level 3: Exceptional maintenance

8.6.2. Equipotential plate

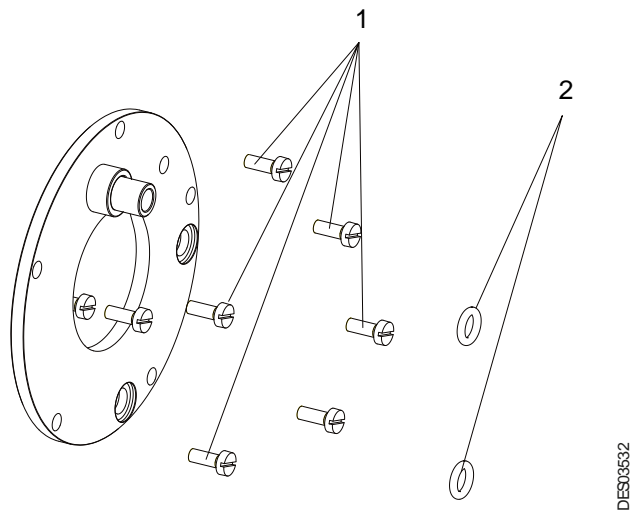

DES03532

Item	P/N	Description	Qty	Unit of sale	Maintenance level for spare part (*)
	910002722	Equipotential plate	1	1	3
1	X7CVCB066	Screw C M4 x 8 brass	8	1	2
2	J2FTDF059	O-ring - viton	2	1	1

(*)

Level 1: Standard preventive maintenance

Level 2: Corrective maintenance

Level 3: Exceptional maintenance

DECLARATION UE DE CONFORMITE
EU DECLARATION OF CONFORMITY
EU- KONFORMITÄTSEKTLÄRUNG
DECLARACIÓN UE DE CONFORMIDAD
DICHIARAZIONE DI CONFORMITÀ UE DECLARAÇÃO
UE DE CONFORMIDADE
EU-CONFORMITEITSVERKLARING



EU-FÖRSÄKRAN OM ÖVERENSSTÄMMELSE
EU- VAATIMUKSEN MUKAISUUSVAKUUTUS
DEKLARACJA ZGODNOŚCI UE
EU PROHLÁŠENÍ O SHODĚ
IZJAVA EU O SKLADNOSTI
VYHLÁŠENIE O ZHODE
EU-MEGFELELŐSÉGI NYILATKOZAT
DECLARATIA DE CONFORMITATE UE

Le fabricant / The manufacturer / Der Hersteller / El fabricante / Il produttore / O fabricante / De fabrikant / Tillverkare / Valmistaja / Producent / Výrobce / Proizvajalec / Výrobca / Gyártó / Fabricantul:	SAMES KREMLIN SAS 13, chemin de Malacher 38 240 - MEYLAN - FRANCE Tél. : 33 (0)4 76 41 60 60
---	--

Déclare que le matériel désigné ci-après / Herewith declares that the equipment / erklårt hiermit, dass die / Declara que el material designado a continuación / Dichiaro che il materiale sottoindicato / Declara que o material a seguir designado / verklaart dat de hieronder aangeduide apparatuur / Kungör att den utrustning som anges här nedan / ilmoittaa, että alla mainitut laitteistot / Oświadcza, że wymienione poniżej urządzenia / Prohlašuje, že níže uvedené vybavení / Izjavlja, da je opisana oprema spodaj / Vyhlasuje, že zariadenie uvedené nižšie / Kijelenti, hogy a megjelölt anyag a továbbiakban / Declară că echipamentul precizat mai jos:

EQUIPEMENT AUTOMATIQUE DE PULVERISATION DE PEINTURE / AUTOMATIC PAINT SPRAY SYSTEM

NANOBELL 2 - UHT158 - GNM200 ou/or GNM300

Est conforme à la législation d'harmonisation de l'Union applicable suivante / Is in conformity with the relevant Union harmonisation legislation / Erfüllt die einschlägigen Harmonisierungsrechtsvorschriften der Union / es conforme con la legislación de armonización pertinente de la Unión / è conforme alla pertinente normativa di armonizzazione dell'Unione / in overeenstemming met de desbetreffende harmonisatiewetgeving van de Unie / med den relevanta harmoniserade unionslagstiftningen / on asiaa koskevan unionin yhdenmukaistamislaainsäädännön vaatimusten mukainen / jest zgodny z odnosnymi wymaganiami unijnego prawodawstwa harmonizacyjnego / Shoduje se s nasledující příslušnou evropskou harmonizační legislativou / V skladu s harmonizirano zakonodajo Unije / Je v súlade s uplatniteľnými harmonizačnými právnymi predpismi EÚ / Megfelel a következő alkalmazandó uniós harmonizációs szabályozásnak / Este conform cu legislația aplicabilă de armonizare de mai jos

Directive Compatibilité Electromagnétique / Electromagnetic Compatibility Directive / Richtlinie Für Elektromagnetische Verträglichkeit / Directiva de Compatibilitad Eletromagnética / Direttiva Compatibilita Elettromagnetica / Directiva relativa à Compatibilidade Eletromagnética / Richtlijn Elektromagnetische Compatibiliteit / Direktivet om Elektromagnetisk Kompatibilitet / EMC-direktivi / Dyrektywa Kompatybilności Elektromagnetycznej / Směrnice Pro Elektromagnetickou Kompatibilitu / Direktiva O Elektromagnetni Združljivost / Smernica O Elektromagnetickej Kompatibilite / Az Elektromágneses Összeférhetőségre vonatkozó Irányelv / Directiva Privind Compatibilitatea Electromagnetică	2014/30/UE
Directive ATEX / ATEX Directive / ATEX Richtlinie / Directiva ATEX / Direttiva ATEX / Directiva ATEX / ATEX-Richtlijn / ATEX-direktivet / ATEX-direktivi / Dyrektywa ATEX / Směrnice ATEX / Direktiva ATEX / Smernica ATEX / ATEX-irányelv Pulvérisateur : II 2 G 350 mJ < Ex < 2J GNM200 ou/or GNM300 : II (2) G [350 mJ < Ex < 2J EN 50176:2009 Matériel associé GNM200 ou GNM300 doit être installé en zone sûre (zone non dangereuse) / Associated equipment GNM200 or GNM 300 must be installed in safe zone (non explosive area) Attestation d'examen UE de type / EU-type examination certificate: INERIS 18ATEX0044X Le signe X placé à la suite du numéro d'attestation d'examen UE de type indique que, suite à une coupure de la haute tension lors de l'apparition d'un défaut « di/dt » sécuritaire, tout mouvement susceptible de réduire la distance de sécurité doit être stoppé (arrêt du déplacement du pulvérisateur et arrêt du convoyeur transportant les pièces à pulvériser) avant d'autoriser le réarmement du défaut / "X" placed after the number of the EU-type examination certificate indicates that, following a high-voltage shutdown when a "di/dt" safety fault occurs, any movement that may reduce the safety distance must be stopped (the movement of the sprayer and the movement of the conveyor carrying the parts to spray) before allowing the reset of the defect. Notification Assurance Qualité de Production / Production Quality Assurance Notification : INERIS 07 ATEX Q401 Notifiées par / Notified by : INERIS 0080 – Parc Technologique ALATA – BP 2 - 60550 Verneuil-en-Halatte - France	2014/34/UE

La présente déclaration de conformité est établie sous la seule responsabilité du fabricant / This declaration of conformity is issued under the sole responsibility of the manufacturer / Die alleinige Verantwortung für die Ausstellung dieser Konformitätserklärung trägt der Hersteller / La presente declaración de conformidad se expide bajo la exclusiva responsabilidad del fabricante / La presente dichiarazione di conformità è rilasciata sotto la responsabilità esclusiva del fabbricante / A presente declaração de conformidade é emitida sob a exclusiva responsabilidade do fabricante / Deze conformiteitsverklaring wordt verstrekt onder volledige verantwoordelijkheid van de fabrikant / Denna försäkran om överensstämmelse utfärdas på tillverkarens eget ansvar / Tämä vaatimustenmukaisuusvakuutus on annettu valmistajan yksinomaisella vastuulla / Niniejsza deklaracja zgodności wydana zostaje na wyłączną odpowiedzialność producenta / Toto prohlášení o shodě se vydává na výhradní odpovědnost výrobce / Za izdajo te izjave o skladnosti je odgovoren izključno proizvajalec / Toto vyhlášení o zhode sa vydáva / na vlastnú zodpovednosť výrobcu / Ezt a megfelelőségi nyilatkozatot a gyártó kizárólagos felelőssége mellett adják ti / Prezenta declarație de conformitate este emisă pe răspunderea exclusivă a producătorului.

Directeur Recherche & Développement / Research & Development Director / Direktor für Forschung & Entwicklung / Director de Investigación y Desarrollo / Direttore Ricerca e sviluppo / Diretor de Pesquisa e desenvolvimento / Manager Onderzoek en Ontwikkeling / Direktör för Forskning och Utveckling / Johtaja tutkimus ja kehitys / Dyrektor ds. Badań i rozwoju / Ředitel výzkumu a vývoje / Direktor za raziskave in razvoj / Riaditeľ pre výskum a vývoj / Kutatási és Fejlesztési Igazgató / Director de cercetare și dezvoltare	Richard WŁODARCZYK
---	------------------------

Fait à Meylan, le / Established in Meylan, on / Geschehen zu Meylan, am / En Meylan, a / Redatto a Meylan, / Vastgesteld te Meylan, / Utoformat i Meylan, den / Meylan, Ranska, / Sporządzono w Meylan, dnia / Meylan, dnia / V Meylanu, / V Meylanu dňa / Kelt Meylanban, / Întocmită la Meylan, pe data de 24/08/2021 - 08/24/2021