

DOCUMENTATION

**AIRMIX®**  
**FLUID PRESSURE REGULATOR PH**

**250 - 10 / 120**

Manual : 582.162.110-UK - A

*Date: 06/03/23*

*Supersede: 20/02/20*

*Modif.: Doc. 573.041.212*

**TRANSLATION FROM THE ORIGINAL MANUAL**

***IMPORTANT : Before assembly and start-up, please read and clearly understand all the documents relating to this equipment (professional use only).***

THE PICTURES AND DRAWINGS ARE NON CONTRACTUAL. WE RESERVE THE RIGHT TO MAKE CHANGES WITHOUT PRIOR NOTICE.

**SAMES KREMLIN SAS**

13, chemin de Malacher  
38 240 - MEYLAN - France

 : 33 (0)4 76 41 60 60

**[www.sames-kremlin.com](http://www.sames-kremlin.com)**



**INSTRUCTION MANUAL**

**PRESSURE REGULATOR**  
**for fluid or semi-fluid materials**

*Manual : 2002 573.008.212*

*Date : 11/02/20 - Supersede : 03/03/14*

*Modif. : Update*

**TRANSLATION FROM THE ORIGINAL MANUAL**

***IMPORTANT : Before assembly and start-up, please read and clearly understand all the documents relating to this equipment (professional use only).***

THE PICTURES AND DRAWINGS ARE NON CONTRACTUAL. WE RESERVE THE RIGHT TO MAKE CHANGES WITHOUT PRIOR NOTICE.

**SAMES KREMLIN SAS**

13, chemin de Malacher  
38 240 - MEYLAN - France

**☎ : 33 (0)4 76 41 60 60**

**[www.sames-kremlin.com](http://www.sames-kremlin.com)**



**INSTRUCTION MANUAL**  
**PRESSURE REGULATOR**  
**for fluid or semi-fluid materials**

**TABLE OF CONTENTS**

1. GENERAL SAFETY INSTRUCTIONS .....	2
2. DESCRIPTION .....	3
3. MOUNTING .....	4
4. INSTALLATION .....	4
5. START UP.....	5
6. MAINTENANCE.....	5
7. TROUBLESHOOTING CHART .....	6

The specifications of the regulator - features and maintenance - are available in a documentation enclosed to the manual.

Dear Customer,

You are the owner of our new SAMES KREMLIN pressure regulator and we would like to take this opportunity to thank you.

To make sure your investment will provide full satisfaction, special care has been taken by SAMES KREMLIN during all designing and manufacturing processes.

To obtain the best result, safe and efficient operation of your equipment, we advice you to read and make yourself familiar with this instruction and service manual. Indeed, the non-compliance with instructions and precautions stated in this manual could reduce the equipment working life, result in operating trouble and create unsafe conditions.

## 1. GENERAL SAFETY INSTRUCTIONS



**WARNING : Any misuse of the equipment or accessories can damage them, result in serious body injury, fire or explosion hazard and reduce the equipment working life. Read, understand and comply with the safety instructions hereafter.**

The personnel involved in operating and servicing this equipment must be aware of all safety requirements stated in this manual. The workshop supervisor must be certain that the personnel has perfectly understood the safety instructions and complies with them.

Read all instruction manuals as well as the tags of the equipments before operating the equipment.

Refer to local safety instructions and comply with them.

### ■ INSTALLATION REQUIREMENTS

#### ➔ **Ground the equipments.**

Use the equipment only in a well-ventilated area to prevent from serious body injuries, fire and explosion hazards. Do not smoke in the spray area.

Never stock paints and solvents in the spray area. Always close the pots and the tins.

Always keep the spray area clean and free from debris (solvent, rags,...).

Read paint and solvent manufacturer's technical instructions.

Spraying of some materials may result in hazardous working conditions. To protect the operator, respirator mask, hand cream, glasses and hearing protective earplug are required (Refer to chapter " Safety equipment" of SAMES KREMLIN selection guide).

### ■ EQUIPMENT REQUIREMENTS

The operating pressure of these equipments are particularly high. Consequently, some precautions must be taken in order to prevent from accidents and from unsafe working conditions.

#### ➔ **Never exceed the components maximum pressure of the equipment.**

#### HOSES

Do not use hoses with a maximum burst-proof pressure less than four times the maximum service pressure of the pump (see data sheet).

Be certain the hoses are not crimped, leaking and not unrolled.

Be certain hoses are in good conditions and showing no evidence of damage.

#### ➔ **Use only air hose with static conductor to connect the pump with the spray gun.**

All fittings must be tight and in good condition.

#### PUMP

#### ➔ **Ground the equipment (use the connection on the pump).**

Do not use any product or solvent incompatible with the pump components.

Use the appropriate solvent for the material being sprayed to increase the equipment working life.

## **GUN**

Never wipe the end of the tip with the fingers.

Always depressurize air and hoses before carrying out any servicing on the gun.

Never point the spray gun at anyone or at any part of the body.

## **PRESSURE REGULATOR**

➡ **Assemble conductive hoses upstream and downstream of the regulator.**

### ■ **MAINTENANCE REQUIREMENTS**

**Guards (air motor cover, coupling shields, housings ...) have been designed for safe use of the equipment.**

**The manufacturer will not be held responsible for bodily injury or failure and / or damage to property due to removal or partial removal of the guards.**

➡ **Never modify these equipments.**

Check them daily, keep them in a good condition and replace the worn parts **only with SAMES KREMLIN parts.**

**Before cleaning or removing components of the equipment, it is compulsory :**

- to stop the pump by shutting off the compressed air supply,
- to open the pump drain valve,
- to press the gun trigger to depressurize the hoses.

## **2. DESCRIPTION**

The pressure regulator enables to adjust the fluid pressure into the circuits of low and medium pressure.

The pressure regulator is mounted on the fluid circuit between the pump fluid outlet and the gun fluid inlet. It enables to refine the pressure of the gun. It exists a spring operated model and an air operated model.

The back pressure regulator is mounted on the back fluid circuit. It enables to regulate a constant pressure and to ensure at the same time a fluid circulation into the hoses.

### 3. MOUNTING

Support (optional)

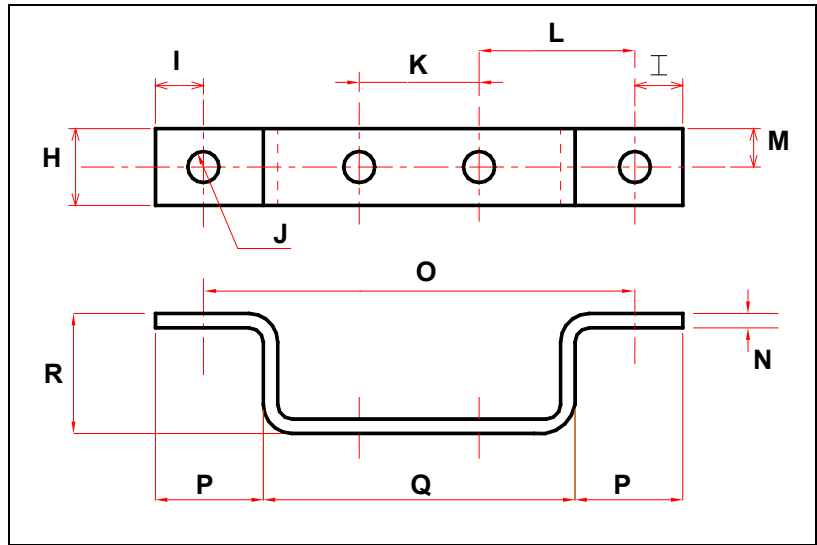
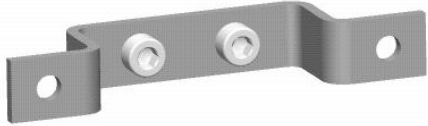

Ind.	mm	"	Ind.	mm	"	Ind.	mm	"	Ind.	mm	"
H	16	0.63	I	10	0.4	J	Ø 6.5	Ø 0.25	K	25	0.98
L	20	0.79	M	8	0.31	N	3	0.12	O	90	3.54
P	22.5	0.88	Q	65	2.56	R	25	0.98			

### 4. INSTALLATION

The pressure regulators are designed to be installed in a spraybooth.

#### ■ INSTALLATION DIAGRAM WITHOUT CIRCULATING

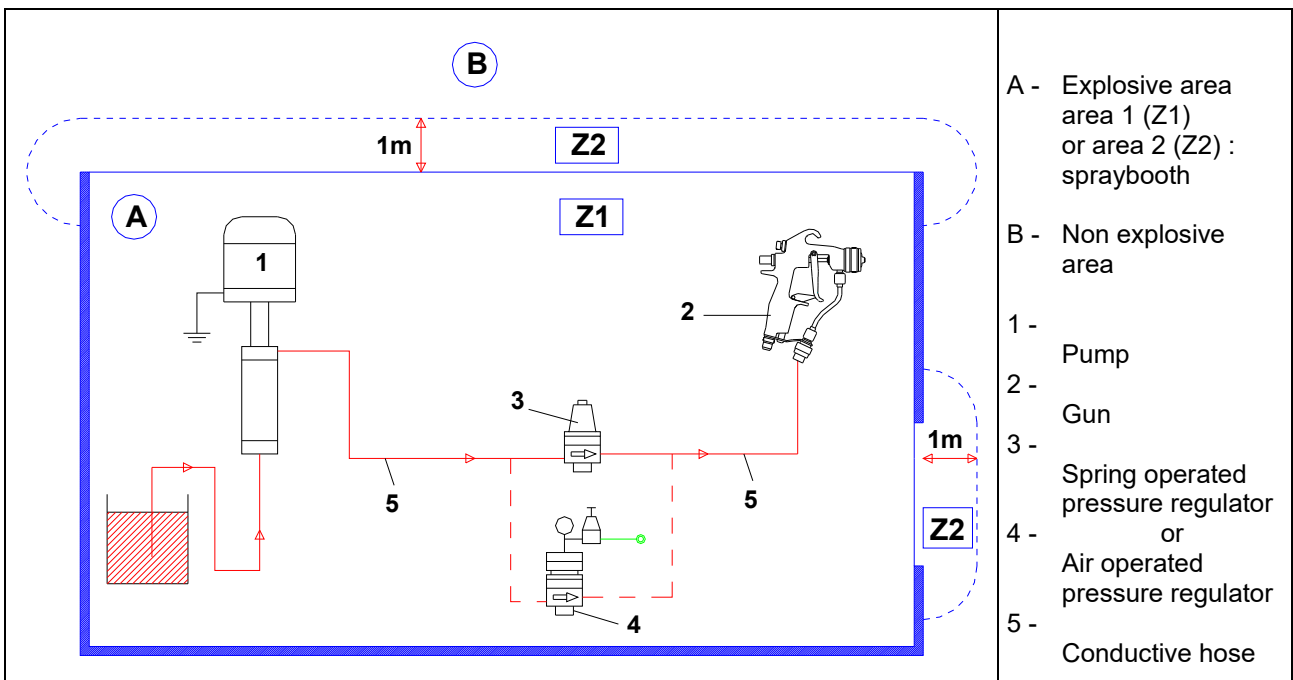

## ■ INSTALLATION DIAGRAM WITH CIRCULATING

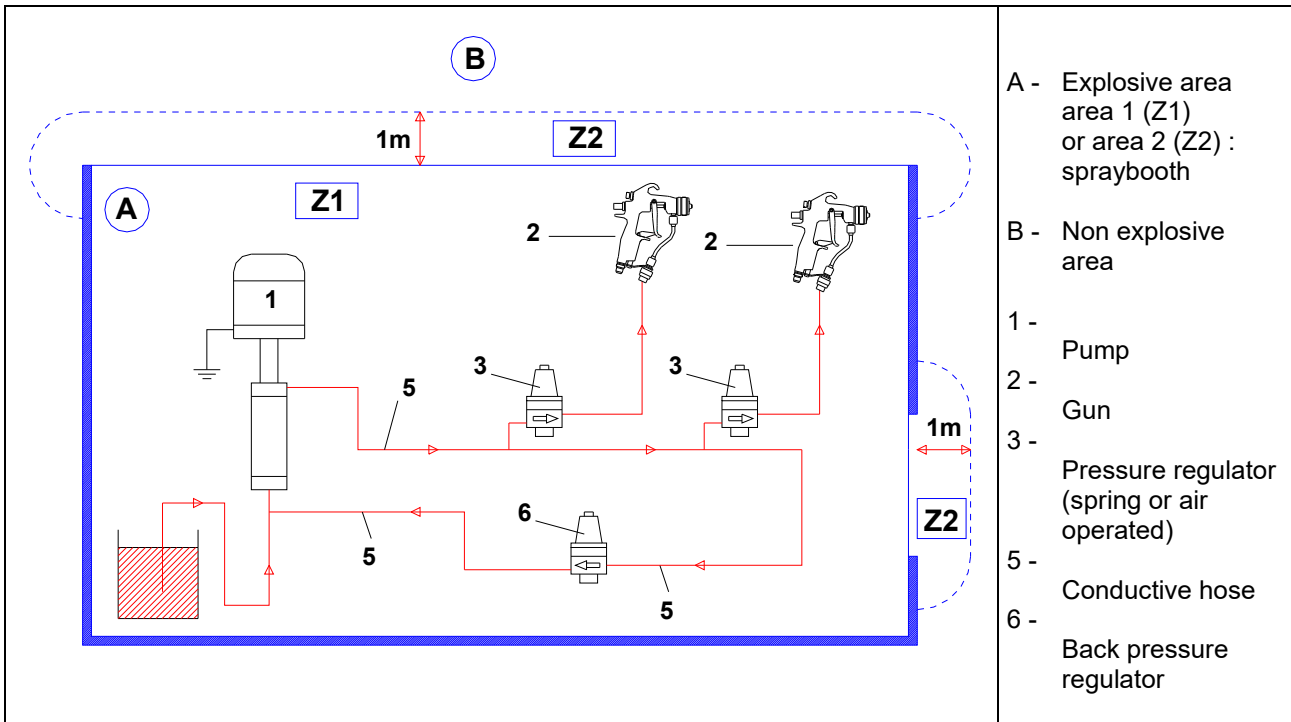

The 1 m / 39.37" distance indicated in these diagrams is given for information purposes only and hold harmless to SAMES KREMLIN. The user is responsible for the extraction and conditioning of the painting area where the equipment is used, for working conditions conditions (refer to EN 60079-10 standard). The 1 m / 39.37" distance may be modified if trials carried out by the user deem this necessary.

(Nota : diagrams represented with Airmix® regulators)



### NOTA :

To ensure a larger lifetime of your equipment and to obtain the best flow rate possible, you must mount the regulator in vertical position.

## 5. START UP

Start up the pump (Refer to pump instruction manual).

Tighten the screw located on the upper part of the spring operated regulator or turn the regulator of the air operated assembly.

Start up the gun (Refer to gun instruction manual).

Adjust the fluid regulator to obtain the required pressure and fluid flow.

**Nota : Refer to the regulator features to comply with the inlet and outlet pressures (refer to the enclosed document).**

## 6. MAINTENANCE

Keep the pressure regulator clean to ensure its proper working.

When flushing the pump, make the solvent circulate in circuit to clean all the elements (pump, hoses, regulator, gun).

## 7. TROUBLESHOOTING CHART

### ■ PRESSURE REGULATOR (AIR OR SPRING OPERATED)

TROUBLE	CAUSE	SOLUTION
Overpressure at the regulator outlet	Adjustment screw or adjustment knob of the regulator turned clockwise (full closed)	Unscrew adjustment screw or knob.
	Air pilot pressure too high	Decrease pilot pressure.
	Bad tightness of seat and ball	Clean or replace.
No material coming out from the regulator	Adjustment screw or knob turned counter-clockwise (full open)	Screw adjustment screw or knob.
	Air pilot pressure insufficient	Increase pilot air pressure.
	Ball blocked on the seat, needle broken	Clean and reinstall or change.
Irregular flow rate	Too much pulsation in the fluid network	Adjust inlet pressure.
	Improper proofness of seat, ball and spring	Clean or replace.
	Regulator in horizontal position	Mount the regulator in vertical position
Leakage at the upper part of the regulator	Defective fluid diaphragm	Replace it.
	Screws improperly tightened on the lower body	Tighten up the screws.

### ■ BACK PRESSURE REGULATOR

DEFECT	CAUSE	SOLUTION
Overpressure upstream of the regulator	Adjustment screw or knob turned clockwise (full closed)	Turn the adjustment screw or knob counter-clockwise.
	Pressure too high in the fluid circuit (or circulating)	Decrease pressure.
Pressure drop upstream of the regulator	Adjustment screw or knob turned counter-clockwise (full open)	Screw the adjustment screw or knob.
	Improper fluid proofness of seat and ball	Clean and reinstall.
Irregular circulation	Too important pulsation in the fluid network	Check and adjust inlet pressure.
	Improper proofness of seat and ball	Clean or replace.
Material leakage at the upper body of the regulator	Defective fluid diaphragm	Replace it.
	Loosened screws on the upper body	Tighten up the screws.



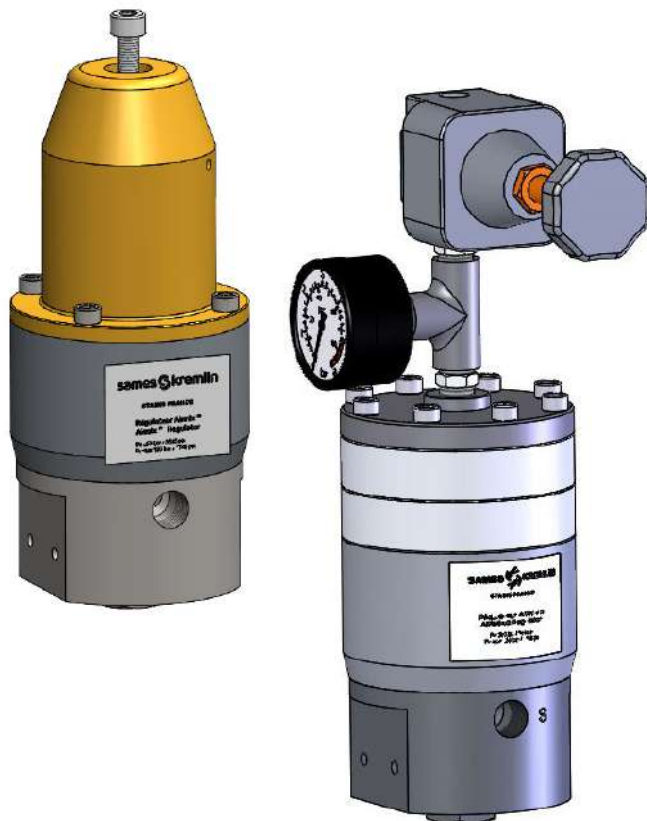

## SPECIFICATIONS

### STAINLESS STEEL AIRMIX® PRESSURE REGULATOR

Models :

250 - 10 / 70

250 - 10 / 120

250 - 10 / 160

120 - 5 / 40

Manual : 2303 573.041.212

Date : 02/03/23 - Supersede : 25/12/18

Modif. : + 250 - 10 / 160

## TRANSLATION FROM THE ORIGINAL MANUAL

**IMPORTANT : Before assembly and start-up, please read and clearly understand all the documents relating to this equipment (professional use only).**

PICTURES AND DRAWINGS ARE NON CONTRACTUAL. WE RESERVE THE RIGHT TO MAKE CHANGES WITHOUT PRIOR NOTICE.

### ADDITIONAL DOCUMENTATIONS

SPARE PARTS :	AIRMIX® regulator	(Doc. 573.328.050)
	AIRMIX® PH regulator	(Doc. 573.361.050)
	AIRMIX® regulator with cartridge	(Doc. 573.374.050)

### **SAMES KREMLIN SAS**

13, chemin de Malacher  
38 240 - MEYLAN - France  
☎ : 33 (0)4 76 41 60 60

[www.sames-kremlin.com](http://www.sames-kremlin.com)

**SPECIFICATIONS**

**STAINLESS STEEL AIRMIX® PRESSURE REGULATOR**

**Manual or piloted version**

**Versions : 250 - 10 / 70, 250 - 10 / 120, 250 - 10 / 160,  
120 - 5 / 40**

## 1. TECHNICAL FEATURES

The AIRMIX® fluid regulator is used on installations that handle fluid or semi-fluid materials.

The regulator is in stainless steel and is designed for a full and easy flushing.

For the manual control regulator : the adjustment of the fluid pressure at the outlet of the regulator is carried out by screwing or unscrewing the adjustment screw (with the wrench n° 6).

For the piloted regulator : the adjustment of the fluid pressure at the outlet of the regulator is carried out by adjusting the air pilot pressure. The pilot air must be driven by a precision air regulator to obtain a better adjustment of the piloted regulator.

The fluid part is the common part of the 2 regulators. An arrow (or the letters **E** and **S**) marked on the body indicates the fluid inlet and the fluid outlet.

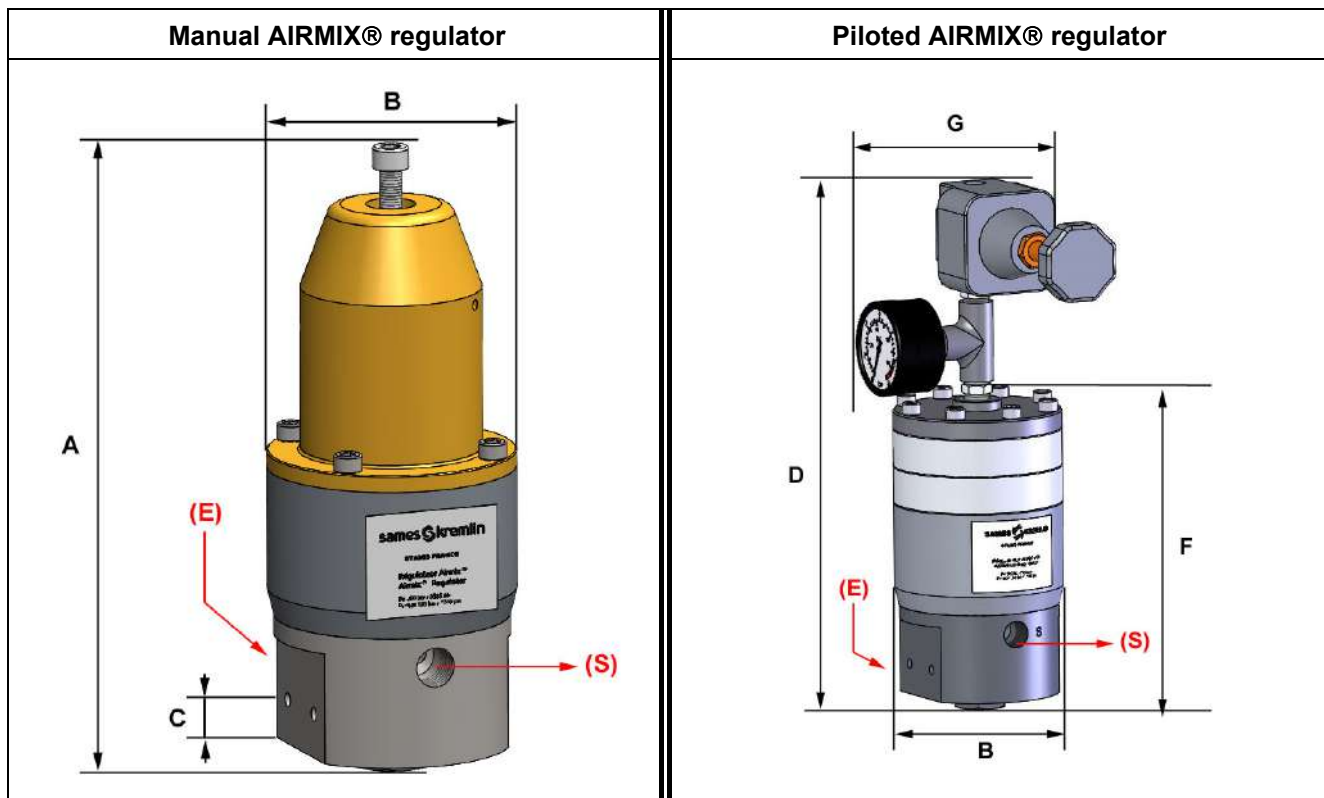

Ind.	mm	"	Ind.	mm	"	Ind.	mm	"	Ind.	mm	"
<b>A</b>	225	8.85	<b>B</b>	Ø 89	Ø 3.5	<b>C</b>	16	0.6	<b>D</b>	275	10.8
<b>F</b>	Max 160	Max 6.3	<b>G</b>	170	6.7						

Type	Manual regulator (by screws)		Air piloted regulator (with pilot regulator)			
Version	250 - 10 / 70	250 - 10 / 120	120 - 5 / 40	250 - 10 / 70	250 - 10 / 120	250 - 10 / 160
Pilot stage number	-		1	2	3	4
Pressure range (bar/psi) :						
- Maximum inlet pressure	250 bar / 3625 psi		120	250 bar / 3625 psi	250 bar / 3625 psi	250 bar / 3625 psi
- Outlet pressure	From 10 to 70 bar / from 145 to 1015 psi	From 10 to 120 psi / from 145 to 1740 psi	From 5 to 40 bar / from 72.5 to 580 psi	From 10 to 70 bar / from 145 to 1015 psi	from 10 to 120 bar / from 145 to 1740 psi	From 10 to 160 bar / from 145 to 2320 psi
- Maximum piloting air pressure	-		6 bar / 87 psi			
Fittings :						
- Fluid inlet (E)	F 3/8 NPS		F 3/8 NPS			
- Fluid outlet (S)	F 3/8 NPS		F 3/8 NPS			
- Air pilot inlet	-		F 1/4 BSP			
Wetted parts	Stainless steel, PTFE, carbide		Stainless steel, PTFE, carbide			
Weight	3.6 kg / 7.9 lb		3.6 kg / 7.9 lb	3.850 kg / 8.5 lb	4.1 kg / 9 lb	4.36 kg / 9.6 lb
Maximum temperature	50°C / 122°F		50°C / 122°F			

#### ■ HOSES WITH FITTINGS RECOMMENDED

You must choose the hose according to the material viscosity and to the length. Make sure the hose has a larger diameter for higher length or important viscosity.

Airmix ® Regulator	Fluid material		Semi-fluid material	
	Fitting	AIRMIX® hose	Fitting	AIRMIX® hose
Inlet (E)	M 3/8 NPT - M 1/2 JIC	∅ 6,35 mm int. (1/4")	M 3/8 NPT - M 3/4 JIC	∅ 9,52 mm int. (3/8")
Outlet (S)	M 3/8 NPT - M 1/2 JIC	∅ 4,8 mm int. (3/16")	M 3/8 NPT - M 1/2 JIC	∅ 4,8 mm int. (3/16") or 6,35 mm int. (1/4")



#### NOTA :

To ensure a larger lifetime of your equipment and to obtain the best flow rate possible, you must mount the regulator in vertical position.

## 2. MAINTENANCE



**WARNING :** Before any action on the installation, shut off the compressed air supply and depressurize the systems by triggering the spray gun.

#### ■ CLEANING OF THE REGULATION VALVE (22)

Unscrew the plug (27). Remove the spring (25) and the ball (24).

Clean the parts with the appropriate cleaning solvent.

Change them if necessary. During the reassembly, change the seal (26).

Reassembly all the parts by holding the regulator vertically. Tighten the plug (27).

## ■ REPLACEMENT OF THE SEAT (23)

### Removal :

Unscrew the 4 screws (18) and remove the lower body (10).

Unscrew the plug (27). Remove the spring (25) and the ball (24).

To remove it from the lower body (10), push on the seat (23).

Clean the parts or replace with new parts.

### Reassembly :

Change the 2 seals (26), the seat (23) and the ball (24) (refer to regulation assembly, 22).

Remount the seat (23), the guide bush (21), the ball (24), the spring (25) and the plug (27).

Remount the lower body (10) and fix it via the 4 screws (18). Respect the screwing torque.

## ■ REPLACEMENT OF THE NEEDLE ASSEMBLY (11) OR OF THE DIAPHRAGMS (13 & 14)

### Removal :

Unscrew the 4 screws (18) and remove the lower body (10).

Unstick the diaphragms from the upper body (19).

Pull carefully the diaphragms to remove the needle assembly (11), the piston (16) and the nut (17).

**Do not pull the needle. This would damage the parts.**

Unscrew the nut (17) to remove the piston (16).

Remove the black diaphragm (13) and the white washer support (14).

Clean the parts or replace with new parts.

### Reassembly :

Replace the seal (15) placed on the needle assembly (11) and the seal (20).

Place the black diaphragm (13) to the air side, the white washer support (14) to the fluid side, and the piston (16).

Place the needle assembly (11) into a vice and tighten at the 2 flats.

Glue with a coating of glue the axis threading (11).

Screw the nut (17) on the needle assembly without using tools, then screw it slightly with a wrench n° 8.

Install the assembly into the upper body (19).

Remount the lower body (10) with the regulation valve (22) and fix it via the 4 screws (18). Respect the screwing torque.

---

**➡ IMPORTANT : when reassembling, the needle of the needle assembly (11) must be inside the central port of the seat (23), until getting in touch with the ball (24).**

---

## ■ REMOVAL - REASSEMBLY OF THE PILOT ASSEMBLY

### Reassembly :

When reassembling, **you shall comply with the alignment of the holes.**

The parts have 9 holes : 8 holes ( $\varnothing$  6.5 mm) for the screws and one hole ( $\varnothing$  4 mm) for the pilot air.

**The air passage must not be obstructed.**

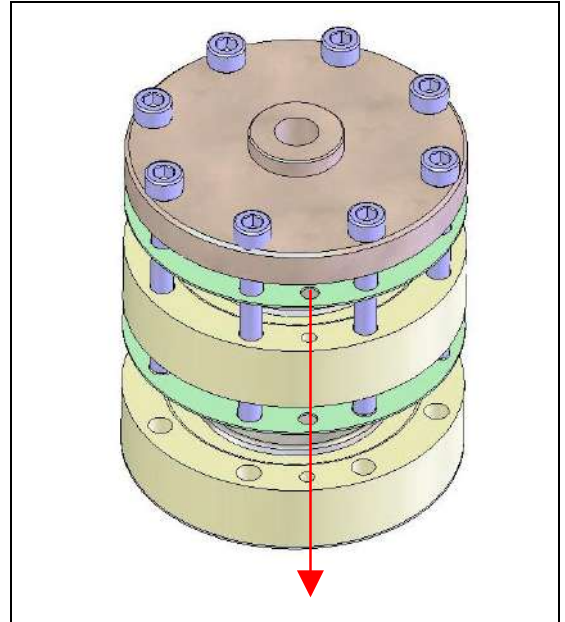

### Before reassembling the different components :

- Clean the part with the appropriate cleaning solvent.
- Install new parts if necessary after having lubricated them with PTFE grease.
- Install new parts if necessary.

## ■ ASSEMBLY INSTRUCTIONS

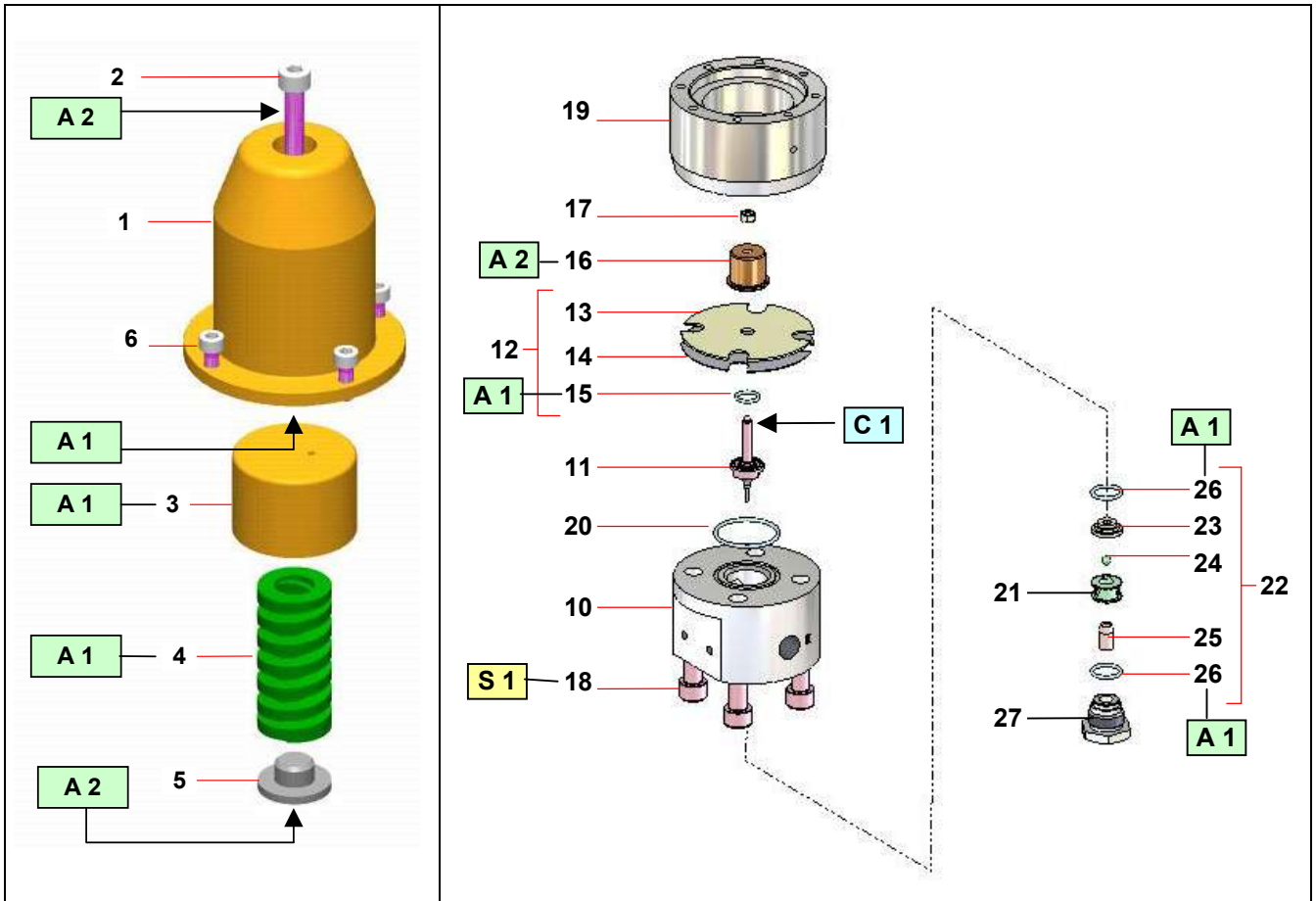

Index	Instructions	Description	Part number
<b>A 1</b>	PTFE grease	"TECHNILUB" grease (10 ml)	560.440.101
<b>A 2</b>	Graphite grease	Graphite grease box (1 kg / 2.204 lb)	560.420.005
<b>C 1</b>	Medium strength - Aneorobic Pipe Sealant - Similar as Loctite 5772		
<b>S 1</b>	Screwing torque : 20 Nm / 14.75 ft/lbs		

<b>Doc. 573.361.050</b> Date/Datum/Fecha : 11/02/20 Annule/Cancel/ Ersetzt/Anula : 08/08/16	<b>Modif. / Änderung :</b> Mise à jour / Update / Aktualisierung / Actualización	<b>Pièces de rechange</b> <b>Spare parts list</b> <b>Ersatzteilliste</b> <b>Piezas de repuesto</b>
--	--	---

<b>REGULATEUR DE PRESSION AIRMIX®, modèle PH (inox 316)</b>	<b>AIRMIX® FLUID PRESSURE REGULATOR, model PH (stainless steel 316)</b>
<b>AIRMIX®-MATERIALDRUCKREGLER, Modell PH (Edelstahl 316)</b>	<b>REGULADOR DE PRESION AIRMIX®, modelo PH (inox 316)</b>

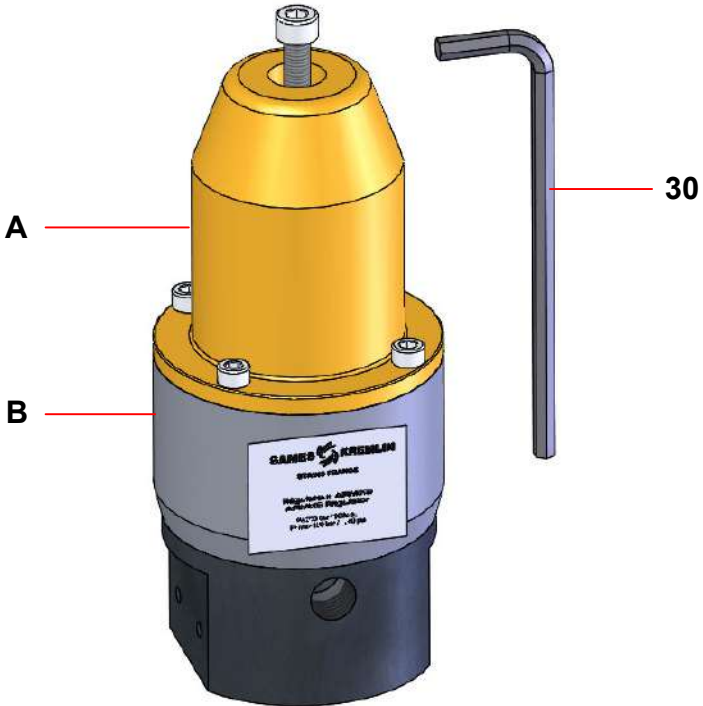
<p><b>REGULATEUR A COMMANDE MANUELLE</b>  <b>MANUAL CONTROL REGULATOR</b>  <b>DRUCKREGLER MIT HANDSTEUERUNG</b>  <b>REGULADOR CON MANDO MANUAL</b></p>	
<p><b>Mod. : 250 - 10 / 120 bar</b>  <b># 155.271.770</b></p>	

**A**

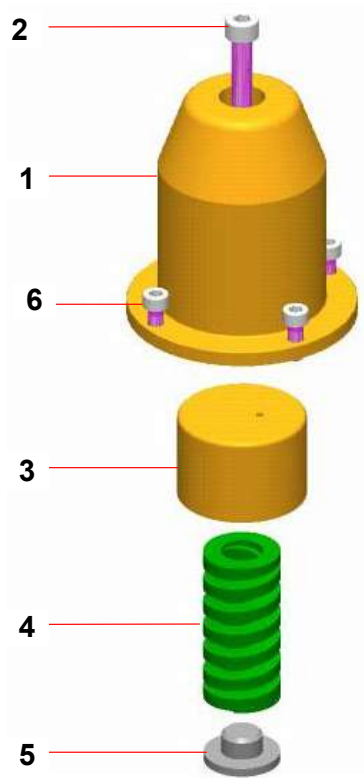

**B**

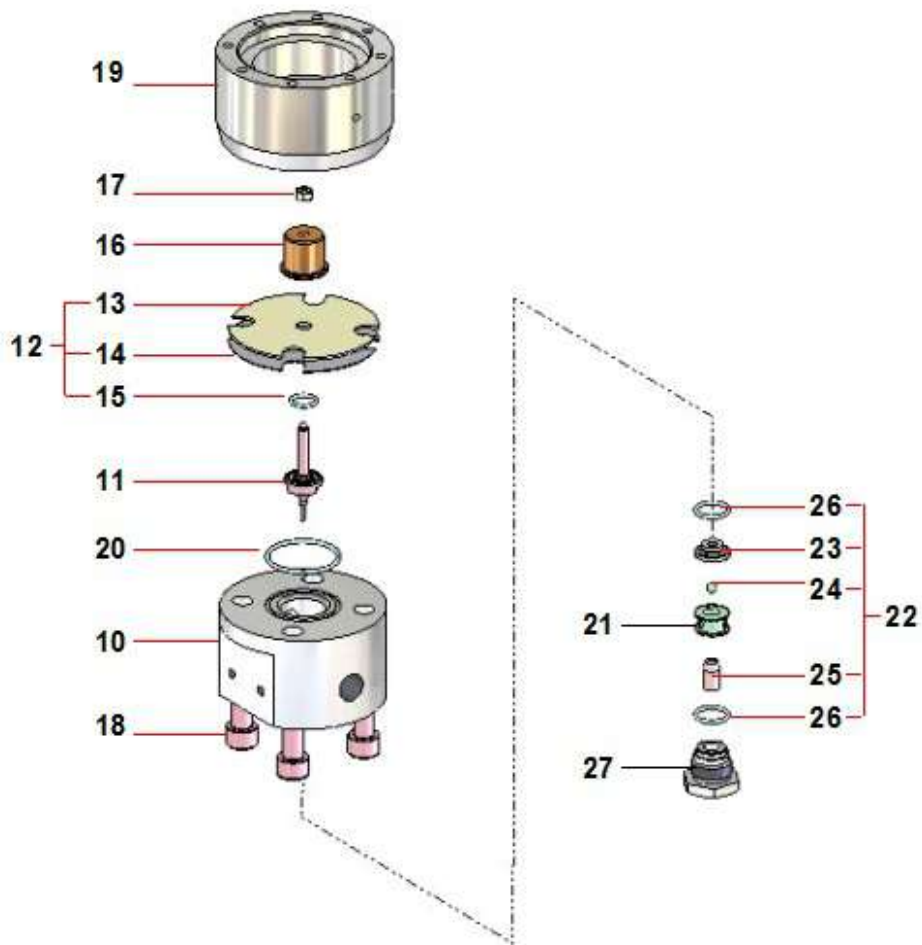



**A COMMANDE MANUELLE / MANUAL CONTROL / HANDSTEUERUNG / MANDO MANUAL**

Ind	#	Désignation	Description	Bezeichnung	Denominación	Qté
1	055 271 721	Chapeau	Hat	Regler, Oberteil	Tapa	1
2	055 271 727	Vis de réglage	Adjustment Screw	Schraube	Tornillo de ajuste	1
3	055 271 724	Guide	Guide	Führung	Guía	1
4	050 319 406	Ressort (rouge)	Spring (red)	Feder (rot)	Muelle (rojo)	1
5	055 271 726	Coupelle	Spring support	Federführung	Copa	1
6	930 151 196	Vis CHc M 6 x 16	Screw, CHc M 6 x 16	Schraube, CHc M 6 x 16	Tornillo CHc M 6 x 16	4

**B PARTIE PRODUIT / PRODUCT PART / MATERIALTEIL / PARTE PRODUCTO**

Ind	#	Désignation	Description	Bezeichnung	Denominación	Qté
10	055 271 777	Corps inférieur	Body, lower	Körper, Unterteil	Cuerpo inferior	1
11	155 271 772	Ensemble axe-aiguille	Needle assembly	Nadeleinheit	Conjunto eje-aguja	1
<b>*12</b>	<b>155 271 902</b>	<b>Membrane équipée</b>	<b>Diaphragm assembly</b>	<b>Membraneinheit</b>	<b>Membrana equipada</b>	<b>1</b>
13	NC / NS	▪ Membrane	▪ Diaphragm	▪ Luftmembran	▪ Membrana	1
14	NC / NS	▪ Contre membrane	▪ Washer support	▪ Materialmembran	▪ Contra membrana	1
15	150 040 332	▪ Joint torique, PTFE (pochette de 10)	▪ O-Ring, PTFE (pack of 10)	▪ PTFE-Dichtung (10 St.)	▪ Junta O-Ring, PTFE (bolsa de 10)	1
*16	055 271 709	Piston	Piston	Materialkolben	Pistón	1
17	953 010 014	Ecrou HM5	Nut, HM5	Mutter, HM5	Tuerca, HM5	1
18	88 173	Vis CHc M 10 x 50	Screw, CHc M 10 x 50	Schraube, CHc M 10 x 50	Tornillo CHc M 10 x 50	4
19	055 271 710	Entretoise de guidage	Body, upper	Körper, Oberteil	Cuerpo guía	1
20	150 040 309	Joint (pochette de 10)	Seal (pack of 10)	Dichtung (10 St.)	Junta (bolsa de 10)	1
21	055 271 778	Bague de guidage	Guide bush	Führungsbuchse	Anillo de dirección	1
<b>*22</b>	<b>155 271 906</b>	<b>Ensemble de régulation</b>	<b>Regulation assembly</b>	<b>Reglereinheit</b>	<b>Conjunto de regulación</b>	<b>1</b>
23	055 271 776	▪ Siège	▪ Seat	▪ Sitz	▪ Asiento	1
24	907 414 308	▪ Bille Ø 5, carbure	▪ Ball Ø 5, carbide	▪ Kugel Ø 5, Hartmetall	▪ Bola Ø 5, carburo	1
25	050 313 211	▪ Ressort conique	▪ Conical, spring	▪ Konische Feder	▪ Muelle cónico	1
26	150 040 314	▪ Joint torique, PTFE (pochette de 10)	▪ O-Ring, PTFE (pack of 10)	▪ PTFE-Dichtung (10 St.)	▪ Junta O-Ring, PTFE (bolsa de 10)	2
27	055 271 779	Bouchon	Plug	Stopfen	Tapón	1

*	<b>155 271 907</b>	<b>Pochette de maintenance (ind. 11, 12, 20, 22)</b>	<b>Servicing kit (ind. 11, 12, 20, 22)</b>	<b>Servicekit (Pos. 11, 12, 20, 22)</b>	<b>Bolsa de reparación (índ. 11, 12, 20, 22)</b>	<b>1</b>
---	--------------------	--	--	---	--	----------

\* Pièces de maintenance préconisées.

\* Preceding the index number denotes a suggested spare part.

\* Bezeichnete Teile sind empfohlene Ersatzteile.

\* Piezas de mantenimiento preventivas.

N C : Non commercialisé.

N S : Denotes parts are not serviceable separately.

N S : bezeichnete Teile gibt es nicht einzeln, sondern nur komplett.

N C : no suministrado.

**ACCESSOIRES - ACCESORIES - ZUBEHÖR - ACCESORIOS**



Ind	#	Désignation	Description	Bezeichnung	Denominación	Qté
51	906 300 213	Clé de 6	Wrench	Inbusschlüssel, Größe 6	Llave	1

**OPTION - ON REQUEST - OPTIONAL - OPCIÓN**

Ind	#	Désignation	Description	Bezeichnung	Denominación	Qté
*22	155 271 731	Kit siège-bille inox (ind. 23, 24, 26)	Seat-ball assembly, stainless steel (ind. 23, 24, 26)	Sitz-Kugel Einheit aus Edelstahl (Pos. 23, 24, 26)	Conjunto asiento-bola, inox (ind. 23, 24, 26)	1
23	055 271 212	▪ Siège	▪ Seat	▪ Sitz	▪ Asiento	1
24	907 414 404	▪ Bille Ø 5, inox	▪ Ball Ø 5, stainless steel	▪ Kugel Ø 5, Edelstahl	▪ Bola Ø 5, inox	1
26	150 040 314	▪ Joint torique, PTFE (pochette de 10)	▪ O-Ring, PTFE (pack of 10)	▪ PTFE-Dichtung (Satz mit 10 St.)	▪ Junta O-Ring , PTFE (bolsa de 10)	2

**Produits hydrodiluable et abrasifs / Water-based and abrasive product  
/ Für wasserbasis und abrasive Produkte / Productos hidrosolubles y abrasivos**

*	155 271 793	Pochette de maintenance cartouche - bille céramique (ind. 23, 24, 25, 26)	Servicing kit cartridge - ball ceramic (ind. 23, 24, 25, 26)	Servicekit Packung - Keramik Kugel (Pos. 23, 24, 25, 26)	Bolsa de reparación cartucho - bola cerámica (ind. 23, 24, 25, 26)	1
23	055 271 212	▪ Siège	▪ Seat	▪ Sitz	▪ Asiento	1
24	907 414 701	▪ Bille Ø 5, céramique	▪ Ball Ø 5, ceramic	▪ Kugel Ø 5, Keramik	▪ Bola Ø 5, cerámica	1
25	050 313 211	▪ Ressort conique	▪ Conical, spring	▪ Konische Feder	▪ Muelle cónico	1
26	150 040 314	▪ Joint torique, PTFE (pochette de 10)	▪ O-Ring, PTFE (pack of 10)	▪ PTFE-Dichtung (Satz mit 10 St.)	▪ Junta O-Ring, PTFE (bolsa de 10)	2

	#	Désignation	Description	Bezeichnung	Denominación
	155 484 010	Support pour régulateur	Support, regulator	Wandhalterung für Regler	Soporte para regulador
	155 271 790	Manomètre à membrane équipé (0-250 bar)	Diaphragm pressure gauge (0-250 bar / 0-3625 psi)	Manometer mit Membran-Druckmittler (0-250 bar)	Manómetro con membrana equipado (0-250 bar)