

DOCUMENTATION  
**AUTOMATIC SPRAY GUN**  
**A3**

**Manual : 582.065.110-UK - 2110**

*Date: 27/10/21*

*Supersede : 27/07/21*

*Modif.: Update*

**TRANSLATION FROM THE ORIGINAL MANUAL**

***IMPORTANT : Before assembly and start-up, please read and clearly understand all the documents relating to this equipment (professional use only).***

THE PICTURES AND DRAWINGS ARE NON CONTRACTUAL. WE RESERVE THE RIGHT TO MAKE CHANGES WITHOUT PRIOR NOTICE.

**SAMES KREMLIN SAS**  
13, chemin de Malacher  
38 240 - MEYLAN - France  
 : 33 (0)4 76 41 60 60  
**[www.sames-kremlin.com](http://www.sames-kremlin.com)**



<p align="center"><b>FR</b></p> <p><b>Pour une utilisation sure, Il est de votre responsabilité de :</b></p> <ul style="list-style-type: none"> <li>• D'installer, d'utiliser, d'entretenir et de réparer l'équipement conformément aux préconisations de <b>SAMES KREMLIN</b> ainsi qu'aux réglementations nationales et/ou locales,</li> <li>• Vous assurez que les utilisateurs de cet équipement ont été formés, ont parfaitement compris les règles de sécurité et qu'ils les appliquent.</li> </ul>	<p align="center"><b>UK</b></p> <p><b>To ensure safe use of the machinery, it is your responsibility to:</b></p> <ul style="list-style-type: none"> <li>• Install, use, maintain and repair the machinery in accordance with <b>SAMES KREMLIN's</b> recommendations and national and/or local regulations,</li> <li>• Make sure that the users of the machinery have received proper training and that they have perfectly understood the safety rules and apply them.</li> </ul>	<p align="center"><b>DE</b></p> <p><b>Eine sichere Nutzung setzt voraus, dass Sie: :</b></p> <ul style="list-style-type: none"> <li>• die Anlage im Einklang mit den Empfehlungen von <b>SAMES KREMLIN</b> sowie mit den nationalen und/oder lokalen Bestimmungen installieren, verwenden, warten und reparieren,</li> <li>• sich vergewissern, dass die Nutzer dieser Anlage angemessen geschult wurden, die Sicherheitsbestimmungen verstanden haben und sie anwenden.</li> </ul>
<p align="center"><b>ES</b></p> <p><b>Para una utilización segura, será de su responsabilidad:</b></p> <ul style="list-style-type: none"> <li>• instalar, utilizar, efectuar el mantenimiento y reparar el equipo con arreglo a las recomendaciones de <b>SAMES KREMLIN</b> y a la normativa nacional y/o local,</li> <li>• cerciorarse de que los usuarios de este equipo han recibido la formación necesaria, han entendido perfectamente las normas de seguridad y las aplican.</li> </ul>	<p align="center"><b>IT</b></p> <p><b>Per un uso sicuro, vi invitiamo a:</b></p> <ul style="list-style-type: none"> <li>• installare, utilizzare, mantenere e riparare l'apparecchio rispettando le raccomandazioni di <b>SAMES KREMLIN</b>, nonché le normative nazionali e/o locali,</li> <li>• accertarvi che gli utilizzatori dell'apparecchio abbiano ricevuto adeguata formazione, abbiano perfettamente compreso le regole di sicurezza e le applichino.</li> </ul>	<p align="center"><b>PT</b></p> <p><b>Para uma utilização segura, é da sua responsabilidade:</b></p> <ul style="list-style-type: none"> <li>• Proceder à instalação, utilização, manutenção e reparação do equipamento de acordo com as preconizações de <b>SAMES KREMLIN</b>, bem como com outros regulamentos nacionais e/ou locais aplicáveis,</li> <li>• Assegurar-se que os utilizadores do equipamento foram devidamente capacitados, compreenderam perfeitamente e aplicam as devidas regras de segurança.</li> </ul>
<p align="center"><b>NL</b></p> <p><b>Voor een veilig gebruik dient u:</b></p> <ul style="list-style-type: none"> <li>• het apparaat te installeren, gebruiken, onderhouden en repareren volgens de door <b>SAMES KREMLIN</b> gegeven aanbevelingen en overeenkomstig de nationale en/of plaatselijke reglementeringen,</li> <li>• zeker te stellen dat de gebruikers van dit apparaat zijn opgeleid, de veiligheidsregels perfect hebben begrepen en dat zij die ook toepassen.</li> </ul>	<p align="center"><b>SE</b></p> <p><b>För en säker användning av utrustningen ansvarar ni för följande:</b></p> <ul style="list-style-type: none"> <li>• Installera, använd, underhåll och reparera utrustningen enligt anvisningarna från <b>SAMES KREMLIN</b> och enligt nationella och/eller lokala bestämmelser.</li> <li>• Försäkra er om att användare av denna utrustning erhållit utbildning, till fullo förstått säkerhetsföreskrifterna och tillämpar dem.</li> </ul>	<p align="center"><b>FI</b></p> <p><b>Käytön turvallisuuden varmistamiseksi velvollisuutesi on:</b></p> <ul style="list-style-type: none"> <li>• Noudattaa laitteiston asennuksessa, käytössä, kunnossapidossa ja huollossa <b>SAMES KREMLIN</b> in suosituksia sekä kansallisia ja/tai paikallisia määräyksiä,</li> <li>• Varmistaa, että laitteiston käyttäjät ovat koulutettuja ja ymmärtävät täysin turvallisuusmääräykset ja miten niitä sovelletaan.</li> </ul>
<p align="center"><b>PL</b></p> <p><b>Dla zapewnienia bezpiecznego użytkowania na użytkownika spoczywa obowiązek:</b></p> <ul style="list-style-type: none"> <li>• Instalowania, użytkowania, konserwacji i naprawy urządzenia zgodnie z zaleceniami firmy <b>SAMES KREMLIN</b> oraz z przepisami miejscowymi,</li> <li>• Upewnienia, że wszyscy przeszkoleni użytkownicy urządzenia zrozumieli zasady bezpieczeństwa i stosują się do nich.</li> </ul>	<p align="center"><b>CZ</b></p> <p><b>Pro bezpečné používání jste povinni:</b></p> <ul style="list-style-type: none"> <li>• Nainstalovat, používat, udržovat a opravovat zařízení v souladu s pokyny firmy <b>SAMES KREMLIN</b> a s národními a/nebo místními legislativními předpisy,</li> <li>• Ujistit se, že uživatelé tohoto zařízení byli vyškoleni, že dokonale pochopili bezpečnostní pravidla a že je dodržují.</li> </ul>	<p align="center"><b>SI</b></p> <p><b>Za varno uporabo ste dolžni:</b></p> <ul style="list-style-type: none"> <li>• inštalirati, uporabljati, vzdrževati in popravljati opremo po določilih <b>SAMES KREMLIN</b> in v skladu z veljavnimi nacionalnimi in/ali lokalnimi predpisi,</li> <li>• poskrbeti, da so uporabniki te opreme ustrezno usposobljeni, poznajo varnostne predpise in da jih upoštevajo.</li> </ul>
<p align="center"><b>SK</b></p> <p><b>V záujme bezpečného je vašou povinnosťou:</b></p> <ul style="list-style-type: none"> <li>• nainštalovať, používať, udržiavať a opravovať zariadenie v súlade s odporúčaniami spoločnosti <b>SAMES KREMLIN</b> a národnými a/alebo miestnymi predpismi,</li> <li>• uistiť sa, že používatelia tohto zariadenia boli zaškolení, riadne porozumeli pravidlám bezpečnosti a používajú ich.</li> </ul>	<p align="center"><b>HU</b></p> <p><b>A biztonságos használat érdekében az Ön felelőssége, hogy:</b></p> <ul style="list-style-type: none"> <li>• a berendezést a <b>SAMES KREMLIN</b> ajánlásainak valamint a nemzeti és/vagy helyi szabályozásoknak megfelelően helyezze üzembe, használja, tartsa karban és javítsa,</li> <li>• megbizonyosodjon róla, hogy a berendezés felhasználói képzettek, tökéletesen megértették és alkalmazzák a biztonsági előírásokat.</li> </ul>	<p align="center"><b>RO</b></p> <p><b>Pentru o utilizare sigură, este responsabilitatea dvs. să:</b></p> <ul style="list-style-type: none"> <li>• Instalați, utilizați, întrețineți și reparați echipamentul conform instrucțiunilor <b>SAMES KREMLIN</b> precum și reglementărilor naționale și/sau locale,</li> <li>• Vă asigurați că utilizatorii acestui echipament au fost instruiți, au înțeles perfect regulile de securitate și le aplică integral.</li> </ul>

Déclaration(s) de conformité au verso de ce document / Declaration(s) of conformity at the back of this document / Konformitätserklärung(en) auf der Rückseite dieser Unterlage / Declaración (es) de conformidad en el reverso de este documento / Dichiarazione/i di conformità sul retro del presente documento / Declaração(ões) de conformidade no verso do documento / Conformanceverklaring(en) op de keerzijde van dit document / Försäkran om överensstämmelse på omstående sida av detta dokument / Vaatimustenmukaisuusvakuutukset tämän asiakirjan kääntöpuolella / Deklaracja(e) zgodności na odwrocie dokumentu / Prohlášení o shodě se nachází/nacházejí na zadní straně tohoto dokumentu / Deklaracija(e) o skladnosti na hrbtni strani tega dokumenta / Vyhlásenie/-a o zhode sa nachádzajú na zadnej strane dokumentu / A dokumentum hátlapján szereplő megfelelőségi nyilatkoz(ok) / Declarații de conformitate pe versoul acestui document



**DECLARATION UE DE CONFORMITE**  
**EU DECLARATION OF CONFORMITY**  
**EU- KONFORMITÄTSEKTLÄRUNG**  
**DECLARACIÓN UE DE CONFORMIDAD**  
**DICHIARAZIONE DI CONFORMITÀ UE**  
**DECLARAÇÃO UE DE CONFORMIDADE**  
**EU-CONFORMITEITSVERKLARING**  
**EU-FÖRSÄKRAN OM ÖVERENSSTÄMMEELSE**  
**EU- VAATIMUKSEN MUKAISUUSVAKUUTUS**  
**DEKLARACJA ZGODNOŚCI UE**  
**EU PROHLÁŠENÍ O SHODĚ**  
**IZJAVA EU O SKLADNOSTI**  
**EÜ VYHLÁSENIE O ZHODE**  
**EU-MEGFELELŐSÉGI NYILATKOZAT**  
**DECLARAȚIA DE CONFORMITATE UE**

Le fabricant / The manufacturer / Der Hersteller / El fabricante / Il produttore / O fabricante / De fabrikant / Tillverkare / Valmistaja / Producent / Výrobce / Proizvajalec / Výrobca / Gyártó / Fabricantul :	<b>SAMES KREMLIN SAS</b> 13, chemin de Malacher 38 240 - MEYLAN - FRANCE Tél. : 33 (0)4 76 41 60 60
--	--

Déclare que le matériel désigné ci-après / Herewith declares that the equipment / erklart hiermit, dass die / Declara que el material designado a continuación / Dichiaro che il materiale sottoidicato / Declara que o material a seguir designado / verklaart dat de hieronder aangeduide apparatuur / Kungör att den utrustning som anges här nedan / ilmoittaa, että alla mainitut laitteistot / Oświadczam, że wymienione poniżej urządzenia / Prohlašuje, že níže uvedené vybavení / Izjavlja, da je opisana oprema spodaj / Vyhlasuje, že zariadenie uvedené nižšie / Kijelenti, hogy a megjelölt anyag a továbbiakban / Declară că echipamentul precizat mai jos :

**PISTOLETS AUTOMATIQUES DE PULVERISATION PNEUMATIQUES / AIRSPRAY AUTOMATIC SPRAYING GUNS / AUTOMATIK LUFTSPRITZPISTOLEN / PISTOLAS AUTOMÁTICAS DE PULVERIZACIÓN NEUMÁTICAS**

A 25
A 25 F
A 28
A 29
A 35
A 3

Est conforme à la législation d'harmonisation de l'Union applicable suivante / Is in conformity with the relevant Union harmonisation legislation / Erfüllt die einschlägigen Harmonisierungsrechtsvorschriften der Union / es conforme con la legislación de armonización pertinente de la Unión / è conforme alla pertinente normativa di armonizzazione dell'Unione / Cumpre a seguinte legislação de harmonização da UE aplicável / in overeenstemming met de desbetreffende harmonisatiewetgeving van de Unie / med den relevanta harmoniserade unionslagstiftningen / on asiaa koskevan unionin yhdenmukaistamislainsäädännön vaatimusten mukainen / jest zgodny z odnosnymi wymaganiami unijnego prawodawstwa harmonizacyjnego / Shoduje se s následující příslušnou evropskou harmonizační legislativou / V skladu s harmonizirano zakonodajo Unije / Je v súlade s uplatniteľnými harmonizačnými právnymi predpismi EÚ / Megfelel a következő alkalmazandó uniós harmonizációs szabályozásnak / Este conform cu legislația aplicabilă de armonizare de mai jos :

Directive ATEX / ATEX Directive / ATEX Richtlinie / Directiva ATEX / Direttiva ATEX / Diretiva ATEX / ATEX-Richtlijn / ATEX-direktivet / ATEX-direktivi / Dyrektywa ATEX / Směrnice ATEX / Direktiva ATEX / Smernica ATEX / ATEX-irányelv	
 II 2G Ex h IIB T6 Gb X	
NF EN ISO 80079-36 Juin 2016 NF EN ISO 80079-37 Juin 2016 NF EN 1127-1 Août 2019	
Ex h=> Protection par sécurité de construction (c) / Protection by constructional safety (c) / Schutz durch konstruktive Sicherheit (c) / Protección por seguridad constructiva (c) / Protezione per sicurezza costruttiva (c) / Protecção por segurança construtiva (c) / Bescherming door constructieveiligheid (c) / Säker konstruktion (c) / Suojaus rakenteellisella turvallisuudella (c) / Zabezpečenie za pomocou bezpečieństwa konstrukcyjnego (c) / Ochrana bezpečnou konstrukci (c) / Zaščita s konstrukcijsko varnostjo (c) / Ochrana bezpečnou konštrukciou (c) / Szerkezetbiztonsági védelem (c) / Protecție prin securitate constructivă (c)	<b>2014/34/UE</b>
<b>INERIS 0080 - 60550 Verneuil-en-Halatte - France / no INERIS-CERN 036594 / 21</b>	

La présente déclaration de conformité est établie sous la seule responsabilité du fabricant / This declaration of conformity is issued under the sole responsibility of the manufacturer / Die alleinige Verantwortung für die Ausstellung dieser Konformitätserklärung trägt der Hersteller / La presente declaración de conformidad se expide bajo la exclusiva responsabilidad del fabricante / La presente dichiarazione di conformità è rilasciata sotto la responsabilità esclusiva del fabbricante / A presente declaração de conformidade é emitida sob a exclusiva responsabilidade do fabricante / Deze conformiteitsverklaring wordt verstrekt onder volledige verantwoordelijkheid van de fabrikant / Denna försäkran om överensstämmelse utfärdas på tillverkarens eget ansvar / Tämä vaatimustenmukaisuusvakuutus on annettu valmistajan yksinomaisella vastuulla / Niniejsza deklaracja zgodności wydana zostaje na wyłączną odpowiedzialność producenta / Toto prohlášení o shodě se vydává na výhradní odpovědnost výrobce / Za izdajo te izjave o skladnosti je odgovoren izključno proizvajalec / Toto vyhlásenie o zhode sa vydáva / na vlastnú zodpovednosť výrobcu / Ezt a megfelelőségi nyilatkozatot a gyártó kizárólagos felelőssége mellett adják ti / Prezenta declarație de conformitate este emisă pe răspunderea exclusivă a producătorului.



Hervé WALTER

Directeur Recherche & Développement / Research & Development Director / Direktor für Forschung & Entwicklung / Director de Investigación y Desarrollo / Direttore Ricerca e sviluppo / Diretor de Pesquisa e desenvolvimento / Manager Onderzoek en Ontwikkeling / Direktör för Forskning och Utveckling / Johtaja tutkimus ja kehitys / Dyrektor ds. Badań i rozwoju / Ředitel výzkumu a vývoje / Direktor za raziskave in razvoj / Riaditeľ pre výskum a vývoj / Kutatási és Fejlesztési Igazgató / Director de cercetare și Dezvoltare

Fait à Meylan, le / Established in Meylan, on / Geschehen zu Meylan, am / En Meylan, a / Redatto a Meylan, / Vastgesteld te Meylan, / Utformat i Meylan, den / Meylan, Ranska, / Sporządzono w Meylan, dnia / Meylan, dnia / V Meylanu, / V Meylan dňa / Kelt Meylanban, / Întocmită la Meylan, pe data de 26/10/2021 - 10/26/2021



**DECLARATION UK DE CONFORMITE**  
**UK DECLARATION OF CONFORMITY**  
**UK- KONFORMITÄTSEKTLÄRUNG**  
**DECLARACIÓN UK DE CONFORMIDAD**  
**DICHIARAZIONE DI CONFORMITÀ UK**  
**DECLARAÇÃO UK DE CONFORMIDADE**  
**UK-CONFORMITEITSVERKLARING**  
**UK-FÖRSÄKRAN OM ÖVERENSSTÄMMELSE**  
**UK- VAATIMUKSEN MUKAISUUSVAKUUTUS**  
**DEKLARACJA ZGODNOŚCI UK**  
**UK PROHLÁŠENÍ O SHODĚ**  
**IZJAVA UK O SKLADNOSTI**  
**UK-VYHLÁŠENIE O ZHODE**  
**UK-MEGFELELŐSÉGI NYILATKOZAT**  
**DECLARAȚIA DE CONFORMITATE UK**

Le fabricant / The manufacturer / Der Hersteller / El fabricante / Il produttore / O fabricante / De fabrikant / Tillverkare / Valmistaja / Producent / Výrobce / Proizvajalec / Výrobca / Gyártó / Fabricantul :	<b>SAMES KREMLIN SAS</b> 13, chemin de Malacher 38 240 - MEYLAN - FRANCE Tél. : 33 (0)4 76 41 60 60
--	--

Déclare que le matériel désigné ci-après / Herewith declares that the equipment / erklart hiermit, dass die / Declara que el material designado a continuación / Dichiaro che il materiale sottoidicato / Declara que o material a seguir designado / verklaart dat de hieronder aangeduide apparatuur

/ Kungör att den utrustning som anges här nedan / ilmoittaa, että alla mainitut laitteistot / Oświadcza, że wymienione poniżej urządzenia / Prohlašuje, že níže uvedené vybavení / Izjavlja, da je opisana oprema spodaj / Vyhlasuje, že zariadenie uvedené nižšie / Kijelenti, hogy a megjelölt anyag a továbbiakban / Declară că echipamentul precizat mai jos :

**PISTOLETS AUTOMATIQUES DE PULVERISATION PNEUMATIQUES / AIRSPRAY AUTOMATIC SPRAYING GUNS / AUTOMATIK LUFTSPRITZPISTOLEN / PISTOLAS AUTOMÁTICAS DE PULVERIZACIÓN NEUMÁTICAS**

A 25
A 25 F
A 28
A 29
A 35
A 3

Est conforme à la législation des normes désignées du Royaume-Uni suivante / Is in conformity with the UK statutory requirements / Entspricht den folgenden britischen Rechtsvorschriften für designierte Standards / Cumple con la siguiente legislación de normas designadas del Reino Unido / É conforme alla seguente legislazione sugli standard designati del Regno Unito / Está em conformidade com a seguinte legislação de Normas Designadas do Reino Unido / Voldoet aan de volgende UK Designated Standards wetgeving / Överensstämmer med följande lagstiftning om brittiska standarder (UK Designated Standards) / Noudattaa seuraavia Yhdistyneen kuningaskunnan nimettyjä standardeja koskevaa lainsäädäntöä / Zgodność z następującymi przepisami UK Designated Standards / Splňuje následující britské právní předpisy o určených normách / V skladu z naslednj zakonodajo o imenovanih standardih v Združenem kraljestvu / Je v súlade s nasledujúcimi právnymi predpismi Spojeného kráľovstva o určených normách / Megfelel a következő brit szabványokra vonatkozó jogszabályoknak / Este în conformitate cu următoarea legislație britanică privind standardele desemnate :

<b>SI 2016 No. 1107 'Equipment and Protective Systems Intended for use in Potentially Explosive Atmospheres Regulations 2016'</b>	
 II 2G Ex h IIB T6 Gb X	
Designated standards NF EN ISO 80079-36 Juin 2016 NF EN ISO 80079-37 Juin 2016 NF EN 1127-1 Août 2019 Ex h=> Protection par sécurité de construction (c) / Protection by constructional safety (c) / Schutz durch konstruktive Sicherheit (c) / Protección por seguridad constructiva (c) / Protezione per sicurezza costruttiva (c) / Protecção por segurança construtiva (c) / Bescherming door constructie veiligheid (c) / Säker konstruktion (c) / Suojaus rakenteellisella turvallisuudella (c) / Zabezpečenie za pomocou bezpečnostného konštrukčného (c) / Ochrana bezpečnou konštrukciou (c) / Zaščita s konstrukcijsko varnostjo (c) / Ochrana bezpečnou konštrukciou (c) / Szerkezetbiztonsági védelem (c) / Protecție prin securitate constructivă (c)	<b>SI 2016 No. 1107</b> <b>'Equipment and Protective Systems Intended for use in Potentially Explosive Atmospheres Regulations 2016'</b>
<b>Approved Bodies INERIS 0080 - 60550 Verneuil-en-Halatte - France / no INERIS-CERN 036594 / 21 CLM 25031 - Ellesmere Port - United Kingdom / CML n°</b>	

La présente déclaration de conformité est établie sous la seule responsabilité du fabricant / This declaration of conformity is issued under the sole responsibility of the manufacturer / Die alleinige Verantwortung für die Ausstellung dieser Konformitätserklärung trägt der Hersteller / La presente declaración de conformidad se expide bajo la exclusiva responsabilidad del fabricante / La presente dichiarazione di conformità è rilasciata sotto la responsabilità esclusiva del fabbricante / A presente declaração de conformidade é emitida sob a exclusiva responsabilidade do fabricante / Deze conformiteitsverklaring wordt verstrekt onder volledige verantwoordelijkheid van de fabrikant / Denna försäkran om överensstämmelse utfärdas på tillverkarens eget ansvar / Tämä vaatimustenmukaisuusvakuutus on annettu valmistajan yksinomaisella vastuulla / Niniejsza deklaracja zgodności wydana zostaje na wyłączną odpowiedzialność producenta / Toto prohlášení o shodě se vydává na výhradní odpovědnost výrobce / Za izdajo te izjave o skladnosti je odgovoren izključno proizvajalec / Toto vyhlásenie o zhode sa vydáva / na vlastnú zodpovednosť výrobcu / Ezt a megfelelőségi nyilatkozatot a gyártó kizárólagos felelőssége mellett adják ti / Prezenta declarație de conformitate este emisă pe răspunderea exclusivă a producătorului



Hervé WALTER

Directeur Recherche & Développement / Research & Development Director / Direktor für Forschung & Entwicklung / Director de Investigación y Desarrollo / Direttore Ricerca e sviluppo / Diretor de Pesquisa e desenvolvimento / Manager Onderzoek en Ontwikkeling / Direktör för Forskning och Utveckling / Johtaja tutkimus ja kehitys / Dyrektor ds. Badań i rozwoju / Ředitel výzkumu a vývoje / Direktor za raziskave in razvoj / Riaditeľ pre výskum a vývoj / Kutatási és Fejlesztési Igazgató / Director de cercetare și Dezvoltare

Fait à Meylan, le / Established in Meylan, on / Geschehen zu Meylan, am / En Meylan, a / Redatto a Meylan, / Vastgesteld te Meylan, / Utformat i Meylan, den / Meylan, Ranska, / Sporządzono w Meylan, dnia / Meylan, dnia / V Meylanu, / V Meylan dňa / Kelt Meylanban, / Întocmită la Meylan, pe data de 26/10/2021 - 10/26/2021



# INSTALLATION AND SAFETY INSTRUCTIONS

## TRANSLATION FROM THE ORIGINAL MANUAL

***IMPORTANT*** : Before assembly and start-up, please read and clearly understand all the documents relating to this equipment (professional use only).

THE PICTURES AND DRAWINGS ARE NON CONTRACTUAL. WE RESERVE THE RIGHT TO MAKE CHANGES WITHOUT PRIOR NOTICE.

**SAMES KREMLIN SAS**  
13, chemin de Malacher  
38 240 - MEYLAN - France  
☎ : 33 (0)4 76 41 60 60

**[www.sames-kremlin.com](http://www.sames-kremlin.com)**

# 1. SAFETY INSTRUCTIONS

## GENERAL SAFETY INSTRUCTIONS



**CAUTION :** The equipment can be dangerous if you do not follow our instructions concerning installation and servicing described in this manual and in accordance with applicable European standards and local national safety regulations.

Please carefully read all the instruction literature before operating your equipment.

### **Only trained operators can use the equipment.**

The foreman must ensure that the operator has understood the safety instructions for this equipment as well as the instructions in the manuals for the different parts and accessories.

Read carefully all instruction manuals, label markings before operating the equipment.

Incorrect use may result in injury. This equipment is for professional use only. It must be used only for what it has been designed for. Never modify the equipment. The parts and accessories supplied must be regularly inspected. Defective or worn parts must be replaced.







**Guards (motor cover, coupling shields, connectors,...) have been designed for a safe use of the equipment.**

**The manufacturer will not be held responsible for bodily injury or failure and / or property damage due to destruction, the overshadowing or the partial or total removal of the guards.**

### **Never exceed the equipment components' maximum working pressure.**

Comply with regulations concerning safety, fire risks, electrical regulations in force in the country of final destination of the material. Use only products or solvent compatible with the parts in contact with the material (refer to data sheet of the material manufacturer).

## PICTOGRAMS

					
NIP HAZARD	WARNING MOVING ELEVATOR	WARNING MOVING PARTS	WARNING MOVING SHOVEL	DO NOT EXCEED THIS PRESSURE	HIGH PRESSURE HAZARD
					
RELIEF OR DRAIN VALVE	WARNING HOSE UNDER PRESSURE	WEAR GLASSES OBLIGATORY	WEAR OF GLOVES IS OBLIGATORY	PRODUCT VAPOR HAZARDS	WARNING HOT PARTS OR AREAS
					
ELECTRICAL HAZARD	WARNING FIRE HAZARDS	EXPLOSION HAZARDS	GROUNDING	WARNING (USER)	WARNING SERIOUS INJURIES



## PRESSURE HAZARDS



Current legislation requires that an **air relief valve** be fitted in the air supply circuit to the air motor to prevent over pressurisation. This safety feature, ensures that it is not possible to supply the air motor with excessive air pressure that may cause injury.

Please ensure that a **material drain valve** is fitted in the fluid circuit to drain and depressurise the circuit. Once depressurised and drained, work /servicing may then commence on the equipment. Please remember to close these valves when restarting the system.

## HIGH PRESSURE INJECTION HAZARDS



When working with high pressure equipment, special care is required. Fluid leaks can occur. There is a risk of material being injected to any exposed parts of body, this could cause severe injury :

- medical care must be sought immediately if paint is injected under the skin or in other parts of the body (eyes, fingers).
- never point the spray gun at any one. Never try to stop the spray with your hands or fingers nor with rags or similars.
- **follow the shut down procedure and always depressurize air and fluid circuits** before carrying out any servicing on the gun (cleaning, checking, maintenance of the material or cleaning of the gun nozzles).
- for the guns equipped with a safety device, always lock the trigger when not in use.

## FIRE - EXPLOSION - SPARKS - STATIC ELECTRICITY HAZARDS



A poor earth connection, inadequate ventilation, sparks or static electricity can cause an explosion or fire. to avoid these risks when using or servicing SAMES KREMLIN equipment, the following safety procedures must be followed :

- ensure a good earth connection and ground the parts to be handled i.e. solvents, materials, components and equipment,
- ensure adequate ventilation,
- keep working area clean and free from waste solvents, chemicals, or solid waste i.e. rags, paper and empty chemicals drums,
- never use electrical switches / power if in an atmosphere of volatile solvent vapour,
- stop working immediately in case of electrical arcs,
- never store chemicals and solvents in the working area.
- use paint whose flash point is the highest possible to prevent from any formation of gas and inflammable vapours (refer to materials' safety instructions),
- install a cover on the drums to reduce the diffusion of gas and vapours in the spraybooth.

## TOXIC PRODUCT HAZARDS



Toxic products or vapours can cause severe injury not only though contact with the body, but also if the products are ingested or inhaled. It is imperative :

- to know the material products and their risks,
- notified or hazardous materials must be stored in accordance with the regulations,
- the material must be stored in an appropriate container, never place materials in a container where there is a risk of spillage or leakage,
- a procedure must be applied for the safe disposal of waste material. It must comply with all prevailing regulations and legislations of the country where the equipment is to be used,
- protective clothing should always be worn in compliance with the material manufacturers' recommendations,
- depending on the application and chemical safety instructions, safety glasses, hearing protective earplug, gloves, foot wear, protective masks and possible breathing equipment should be worn to comply with the regulations (Refer to chapter "Safety equipment of SAMES KREMLIN selection guide).



### CAUTION!

It is forbidden to use material containing high concentrations of halogenated hydrocarbon solvents with **aluminium** or **zinc fillers**. Non-compliance with the instructions may cause explosion risk causing serious or fatal injury.



### EQUIPMENT REQUIREMENTS

**Guards (motor cover, coupling shields, connectors,...) have been designed for a safe use of the equipment.**

**The manufacturer will not be held responsible for bodily injury or failure and / or property damage due to destruction, the overshadowing or the partial or total removal of the guards.**

### PUMP



Before carrying out any work, it is imperative to read and clearly understand the disassembly and reassembly instructions before servicing. The operator must understand the equipment and the safety instructions. These instructions are available in the equipment manuals.



The air motor is designed to be mounted with a pump. Never modify any components or couplings. When operating, please keep hands away from moving parts. Before starting up the equipment, please read the PRESSURE RELIEF instructions. Please ensure that any relief or drain valves fitted are in good working order.

### HOSES

- Keep hoses out of circulation areas, moving parts or hot surfaces,
- Never expose product hoses to temperature higher than + 60°C / 140° F or lower than 0°C / 32° F,
- Never pull or use the hoses to move the equipment,
- Tighten all fittings as well as the hoses before operating the equipment,
- Check the hoses regularly; change them if they are damaged,
- Never exceed the maximum working pressure (MWP) indicated on the hose.

### USED PRODUCTS

Considering the wide variety of products that are available and can be used in our equipment it is impossible to check and make recommendations for all chemical data, regarding the risks of possible chemical attack and their long term chemical reaction

SAMES KREMLIN can not be held liable for :

- compatibility of wetted parts,
- risks to staff and the surroundings,
- for worn or defective parts, for faulty equipment or units, or the quality of final product.

It is the responsibility of the user to know and prevent any possible risks such as toxic vapours, fires or explosions. He shall determine the risks of immediate reactions or pursuant to repeated exposures of the staff,

SAMES KREMLIN shall not be liable for physical injuries, direct or indirect material damages caused by the use of chemicals.

## 2. HANDLING



### **Check the weight and the dimensions of the equipment**

**(☞ refer to 'Technical features' section of the instruction manual**

If weight and dimensions are too important, the unloading must be carried out by means of a forklift or any other appropriate means with a qualified personnel and in a clear horizontal area to prevent from risks of damage injury or an accident.

The centre of gravity is not in the centre of the machine : carry out by hand a stability-test after having lifted the whole at 10 cm / 3.937" maximum.

After the unloading, the handling of the whole (eg: elevator pump) is carried out by means of a pallet truck taking the bottom part of the frame.

**Remark : Each pump motor is fitted with a ring. The ring is designed for the hoisting of one pump and can not be used for the handling of the complete assembly.**

## 3. STORING

Storing before installation :

- Storing ambient temperature : 0 / +50 °C / 0 / +122°F
- Protect the whole against dust, water trickling, dampness and shocks.

Storing after installation :

- Operating temperature : +15 / +35 °C / +59 / +138.2° F
- Protect the whole against dust, water trickling, dampness and shocks.

## 4. INSTALLATION OF THE EQUIPMENT

The machine is installed on a stable horizontal floor (for eg a concrete flag).

The machine shall be made stable by the use of holding down bolts or by the use of other anchoring methods, strong enough to prevent unintended bodily movement of the equipment.



**To avoid risks caused by static electricity, the equipment as well as its components must be grounded.**

- **For the pumping equipments** (pumps, pneumatic rams, frame...), a section wire of 2.5 mm<sup>2</sup> is fixed on the material. Use this wire to connect the material to "the general ground". In case of severe environments (mechanical protection of the wire of earthing insufficient, vibrations, mobile material...) where function damages at the ground are probable, the user have to replace the provided wire of 2.5 mm<sup>2</sup> by a device more adapted to its environment (wire with a more important section, bonding strip, fixing by thimble with eyelet...).

The continuity of the ground must be controlled by a qualified electrician. If the continuity of the ground is not ensured, check the terminal, the wire and the earthing point. **Never** use the material without have solved this problem.

- In the severe cases of environments (mechanical protection of the wire of earthing insufficient, vibrations, mobile material...) where damages of the function put at the ground are probable, the user will have to replace the wire of 2.5 mm<sup>2</sup> provided, by a device more adapted to its environment (wire of more important section, bonding strip, fixing by thimble with eyelet...),
- **The gun** must be 'grounded' via a material hose or an air hose. In case of spraying by means of a gun with cup, the air hose must be conductive,
- **The materials to be painted** must also be grounded.

**All the materials situated in the working area shall be grounded.**



- **Never store** more than necessary inflammable materials inside the working area,
- The materials must be stored into **approved drums** and grounded,
- Use only grounded **metals containers** for the use of cleaning solvents,
- **Cardboard and paper are prohibited.**

## 5. MARKING OF THE EQUIPMENT

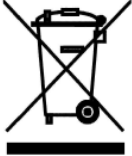

Each equipment has a label plate with the name of the manufacturer, the equipment part number, the interesting informations to use correctly the equipment (pressure, voltage,...) and sometimes the above pictogram.

The equipment is designed with and consists of high quality materials and components which can be re-used.

The 2012/19/UE European Directive covers all equipments with a crossed-out bin pictogram. Please inform yourself about the collection systems for electric and electronic equipments.

Please act in accordance with local rules and **do not dispose of old equipment with household wastes**. A correct disposal of old equipment will help prevent negative consequences for the environment and health.



# **AUTOMATIC AIRSPRAY GUN**

## **A 3**

*Disassembly / Reassembly*

### **TRANSLATION FROM THE ORIGINAL MANUAL**

***IMPORTANT : Before assembly and start-up, please read and clearly understand all the documents relating to the equipment (professional use only).***

THE PICTURES AND DRAWINGS ARE NOT CONTRACTUAL. WE RESERVE THE RIGHT TO MAKE CHANGES WITHOUT PRIOR NOTICE.

**SAMES KREMLIN SAS**

13, chemin de Malacher  
38 240 - MEYLAN - France

 : 33 (0)4 76 41 60 60

**[www.sames-kremlin.com](http://www.sames-kremlin.com)**



**CAUTION :**

Before any intervention on the gun, shut off the compressed air supply and depressurize the circuits controlling the opening of the gun.

**The gun is manufactured under the ATEX agreement and can not be modified. SAMES KREMLIN will not be held responsible for any failure to comply with that instruction.**

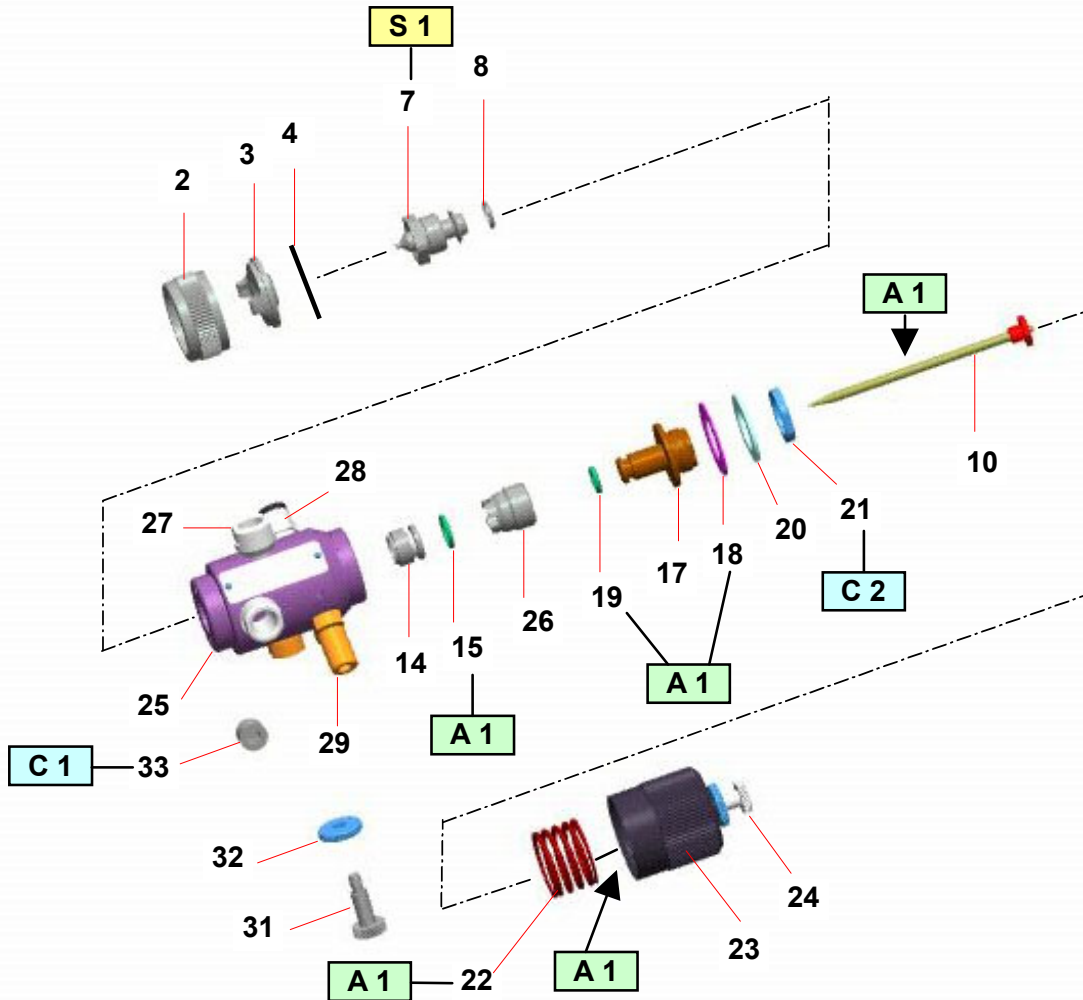

Ind.	Instructions	Description	Part number
A 1	PTFE grease	"TECHNILUB" grease (10 ml / 0.002 US gal)	560.440.101
C 1	Medium strength - Aneorobic Pipe sealant	Loctite 5772 (50 ml / 0.013 US gal)	554.180.015
C 2	Low strength - Anaerobic Adhesive	Loctite 222 (50 ml / 0.013 US gal)	554.180.010
S 1	Screwing torque : 18 Nm / 13.28 ft/lbf		

Before removing a component of the gun, some precautions have to be respected :

- Empty out the paint inside the cup or the receiver.
- Fill the cup or the receiver with cleaning solvent.
- Decrease the supply air pressure of the gun.
- Spray the solvent until it runs clear.
- Shut off the supply air pressure of the gun.
- Shut off the material pressure.
- Trigger the gun to depressurize the circuit.
- Empty out the solvent when using a gravity cup.
- Remove the part to be cleaned or changed.

**Before reassembling the different components, some precautions must be taken :**

- **Clean all the parts with the appropriate cleaning solvent and a brush.**
- **Install new seals if it is necessary after having lubricated them with PTFE grease.**
- **Install new parts if it is necessary.**

#### ▪ PISTON PACKING (18)

Unscrew cylinder (23) - (take care not to damage the spring 22).

Take hold of the entire needle and piston assembly (10 and 16) and pull them towards the back.

Unscrew nut (21). Remove support washer (20) as well as packing (18).

Clean the parts and change them if necessary.

When reinstalling :

**Before inserting piston (17), the packing lip (18) must be shaped by hand as shown opposite.**

Glue nut (21) on piston (17) with Low strength - Aneorobic Adhesive - Loctite 222. Change seal (19).

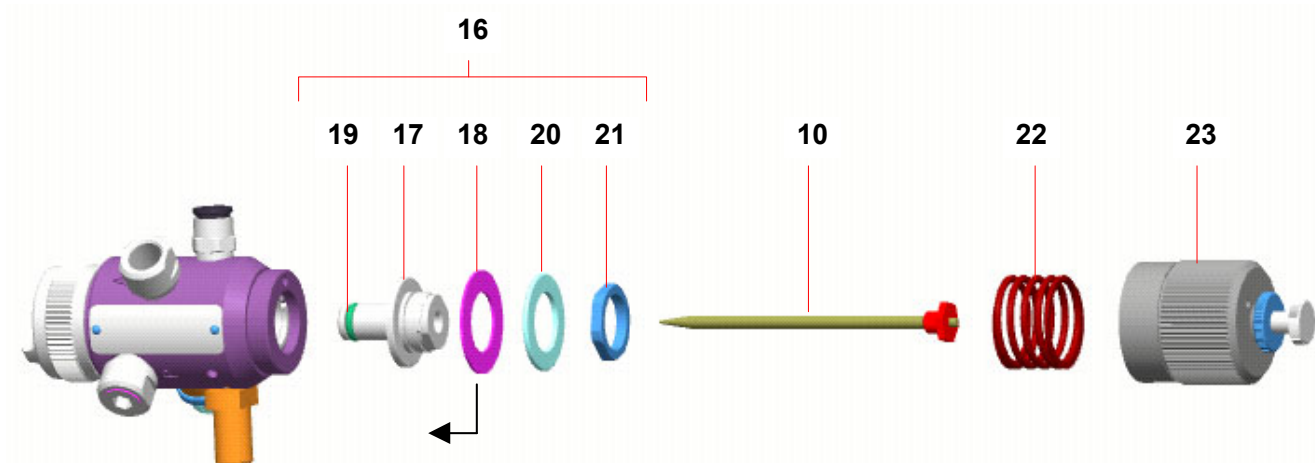

▪ **PACKING HOLDER (13)**

Unscrew cylinder (23) - (take care not to damage the spring 22).

Take hold of the entire needle and piston assembly (10 and 16) and pull them towards the back.

Unscrew sleeve (26).

Remove the packing holder (13) by the rear part of the spray gun.

Clean the inside of the spray gun with solvent and blow out with air.

Change packing holder (13).

When reinstalling, drive packing holder by pushing it inside the body until it comes into contact with the body.

Replace all the parts and change the seals.

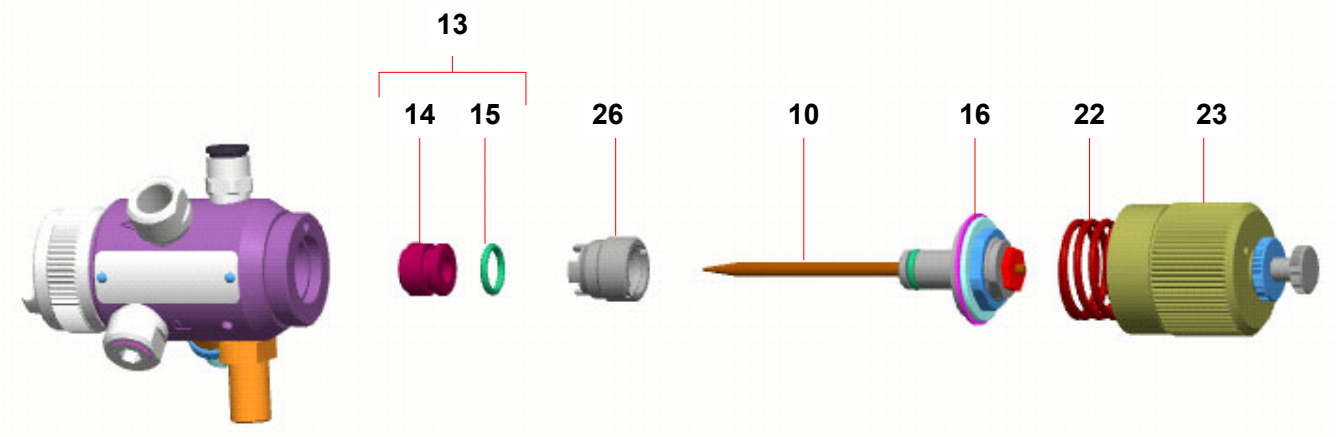



<p><b>Doc. 573.294.050</b>                  Date/Datum/Fecha : 27/10/21                  Annule/Cancel/                  Ersetzt/Anula : 22/06/21</p>	<p><b>Modif. / Änderung :</b> Mise à jour                  / Update / Aktualisierung                  / Actualización</p>	<p><b>Pièces de rechange</b>                  Spare parts list                  Ersatzteilliste                  Piezas de repuesto</p>
---	---	---

<b>PISTOLET AUTOMATIQUE A 3</b>	<b>A 3 AUTOMATIC SPRAY GUN</b>
<b>AUTOMATIKPISTOLE A 3</b>	<b>PISTOLA AUTOMÁTICA A 3</b>

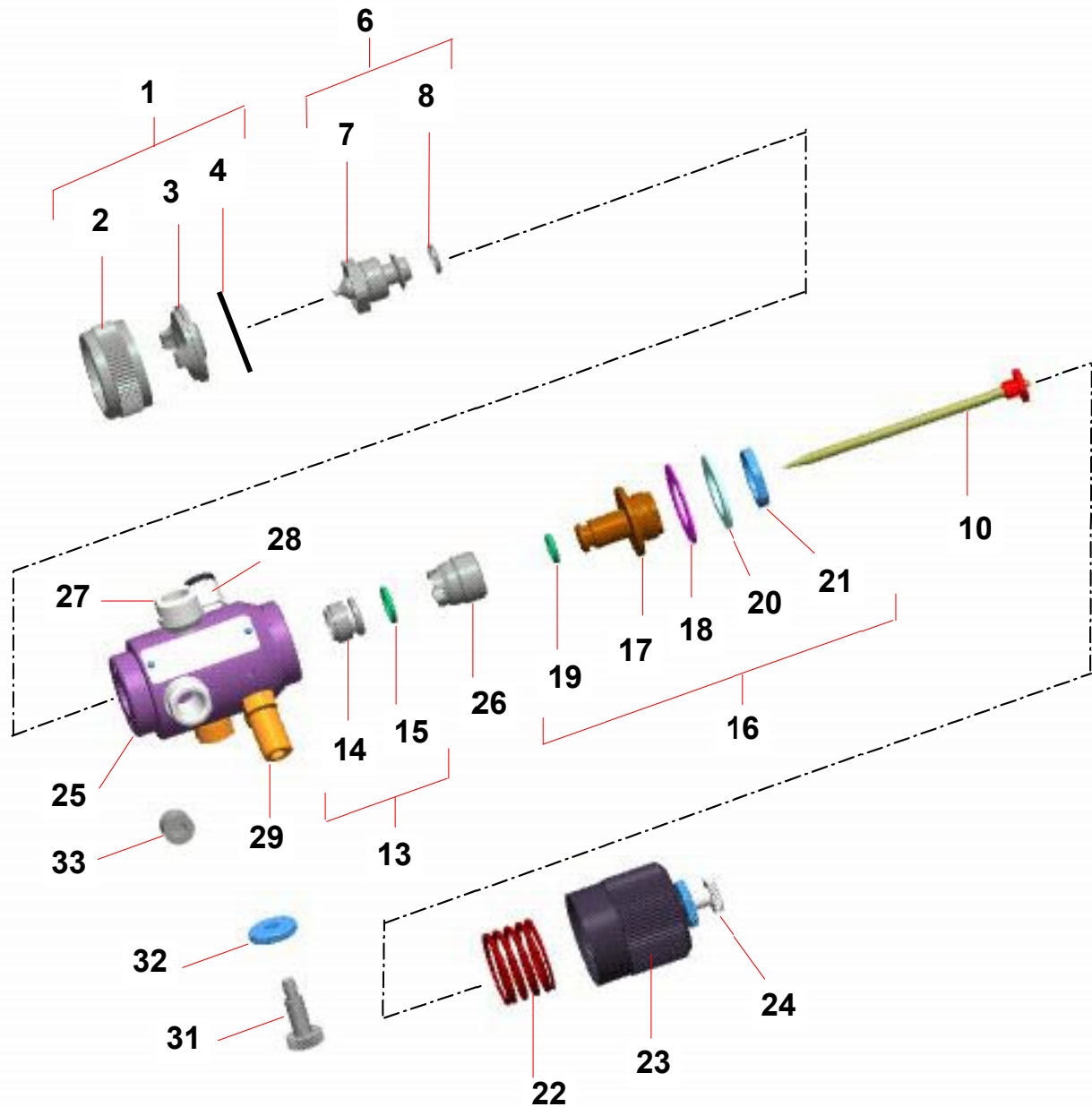











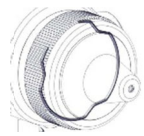
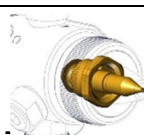
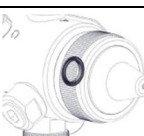

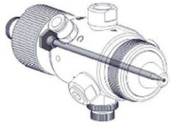
A 3	Modèle standard / standard model Standard Modell / Tipo estandar	Modèle Inox / Stainless steel model Edelstahl Modell / Tipo Inox
+ 08 PX	135 713 014	135 713 020
+ 10 PX	135 713 011	135 713 021
+ 12 PX	135 713 012	135 713 022
+ 06 GL	135 713 017	135 713 018
+10 GL	135 713 015	135 713 019





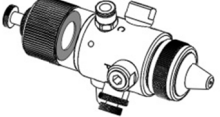

Projecteur / Projector Zerstäubereinheiten / Projector	Tête / Aircap Luftkappe / Cabezal	Buse / Nozzle Düse / Boquilla	Pointeau / Needle Nadel / Aguja
--	--------------------------------------	----------------------------------	------------------------------------

Ind. 1+7+11	#	Ind. 1	#	Ind. 7	Ø (mm / ")	#	Ind. 11	#
08 PX	031 713 014	PX	132 631 100	08	0,8 / 0.03	134 630 400	08	033 713 400
10 PX	031 713 011	PX	132 631 100	10	1,0 / 0.039	134 630 100	10	033 713 000
12 PX	031 713 012	PX	132 631 100	12	1,2 / 0.047	134 630 200	12	033 713 100
06 GL	031 713 017	PL	132 640 100	06 GL	0,6 / 0.024	134 640 300	04 06 GL	033 713 500
10 GL	031 713 015	PL	132 640 100	10 GL	1,0 / 0.039	134 640 100	10 GL	033 713 300

**PIECES DE RECHANGE - PARTS IDENTIFICATION LIST - ERSATZTEILLISTE - PIEZAS DE REPUESTO**

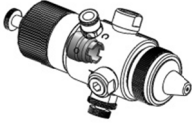
Ind	#	Désignation	Description	Bezeichnung	Denominación	Qté	Visuel Visual illustration Veranschaulichung Ilustración visual
*1	-	Tête complète (voir tableau)	Aircap assembly (refer to chart)	Zerstäuberkopf kpl. (siehe Tabelle)	Cabezal completo (consultar cuadro)	1	
2	029 630 004	• Bague de tête	• Aircap ring	• Überwurfring	• Anillo del cabezal	1	
3	NC / NS	• Tête nue	• Aircap only	• Zerstäuberkopf	• Cabezal solo	1	
4	032 630 102	• Anneau de retenue	• Stop ring	• Sicherungsring	• Anillo de retención	1	
*6	-	Buse équipée (voir tableau)	Nozzle assembly (refer to chart)	Düse kpl. (siehe Tabelle)	Boquilla equipada (consultar cuadro)	1	
7	NC / NS	• Buse	• Nozzle	• Düse	• Boquilla	1	-
8	134 639 901	• Joint de buse (les 5)	• Seal, nozzle (pack of 5)	• O-Ring, Düse (5 St.)	• Junta de boquilla (x 5)	1	

Ind	#	Désignation	Description	Bezeichnung	Denominación	Qté	Visuel Visual illustration Veranschaulichung Ilustración visual
*10	-	Pointeau complet (voir tableau)	Needle assembly (refer to chart)	Farbnadel kpl. (siehe Tabelle)	Aguja completa (consultar cuadro)	1	
*13	129 479 902	Porte-garniture équipé (les 4)	Packing-holder assembly (pack of 4)	Packungshalter (4 St.)	Porta-guarnición equipada (bolsa de 4)	1	
14	NC / NS	• Porte-garniture	• Packing	• Nadelpackung	• Porta-guarnición	1	
15	129 529 906	• Joint (les 10)	• O-Ring (x 10)	• O-Ring (10 St.)	• Junta (x 10)	2	
*16	029 712 200	Piston équipé	Piston assembly	Kolben, kpl.	Pistón equipado	1	
17	NC / NS	• Piston seul	• Piston only	• Kolben, einzeln	• Pistón solo	1	
18	029 711 302	• Garniture	• Packing, piston	• Kolben- manschette	• Garnición del pistón	1	
19	129 400 915	• Joint R5A en FPM (élastomères fluorés) (les 10)	• Seal, R5A FPM (fluorous elastomers) (pack of 10)	• O-Ring R 5A FPM (Elastomer Fluor) (10 St.)	• Junta R5A, FPM (elastómeros fluorados) (bolsa de 10)	1	
20	029 711 303	• Rondelle d'appui	• Support washer	• Stützscheibe	• Arandela de apoyo	1	
21	029 711 304	• Ecrou	• Nut	• Mutter	• Tuerca	1	
*22	050 312 501	Ressort de piston	Spring, piston	Feder für Kolben	Muelle de pistón	1	

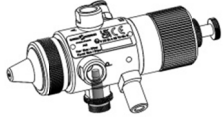
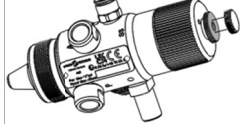
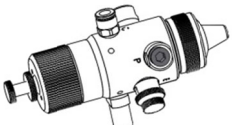
Ind	#	Désignation	Description	Bezeichnung	Denominación	Qté	Visuel Visual illustration Veranschaulichung Ilustración visual
23	029 711 400	Cylindre équipé	Cylinder assembly	Luftzylinder, kpl.	Cilindro equipado	1	
24	129 713 015	• Butée de pointeau	• Adjustment knob	• Nadelanschlag	• Tope de aguja	1	
25	<b>NC / NS</b>	<b>Corps équipé</b>	<b>Body assembly</b>	<b>Pistolenkörper</b>	<b>Cuerpo</b>	<b>1</b>	-
26	029 410 003	• Fourreau	• Sleeve	• Nadelführung	• Vaina	1	
27	029 713 002	• Raccord M 12x100 - F 1/8 NPS	• Fitting M 12x100 - F 1/8 NPS	• Anschluss M 12x1,00 AG - IG 1/8 NPS	• Racor M 12x100 - H 1/8 NPS	3	
28	905 124 901	• Raccord M 1/8 BSP - T 4x6 (air de commande)	• Fitting M 1/8 BSP - T 4x6 (control air)	• Anschluss für Steuerluft AG 1/8 BSP - Schlauch 4x6	• Racor M 1/8 BSP - T 4x6 (air de commande)	1	
29	029 711 102	• Axe de fixation	• Pin, gun mounting	• Achse für Pistolen Halterung	• Eje	1	
31	029 711 001	Vis pointeau	Fan adjustment	Spritzstrahl Regulierschraube	Regulador abanico	1	
32	029 711 002	Contre-écrou	Lock nut	Kontermutter	Contra tuerca	1	
33	906 333 108	Bouchon F 1/8 NPT (pour montage sans circulation)	Plug F 1/8 NPT (for mounting without circulation)	Stopfen AG 1/8 NPT (für Montage ohne Zirkulation)	Tapón H 1/8 NPT (montaje sin circulación)	1	

\* Pièces de maintenance préconisées.

\* Preceding the index number denotes a suggested spare part.

\* Bezeichnete Teile sind empfohlene Ersatzteile.

\* Piezas de mantenimiento preventivas.

N C : Non commercialisé

N S : Denotes parts are not serviceable.

N S : Bezeichnete Teile gibt es nicht einzeln, sondern nur komplett.

N S : no suministrado.

**ACCESSOIRES - ACCESSORIES - ZUBEHÖR - ACCESORIOS**

Ind	#	Désignation	Description	Bezeichnung	Denominación	Qté
41	049 030 021	Clé plate	Gun wrench	Pistolenschlüssel	Llave para pistola	1
42	906 300 102	Goupillon PM	Small size brush	Pistolenreinigungsbürste	Cepillo pequeño	1

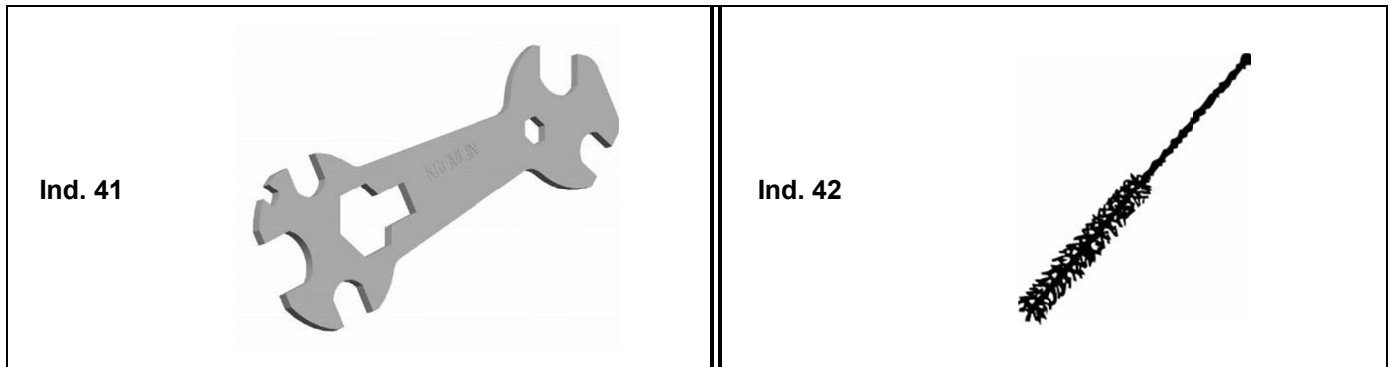

**A LA DEMANDE - ON REQUEST - AUF ANFRAGE - A PETICIÓN**

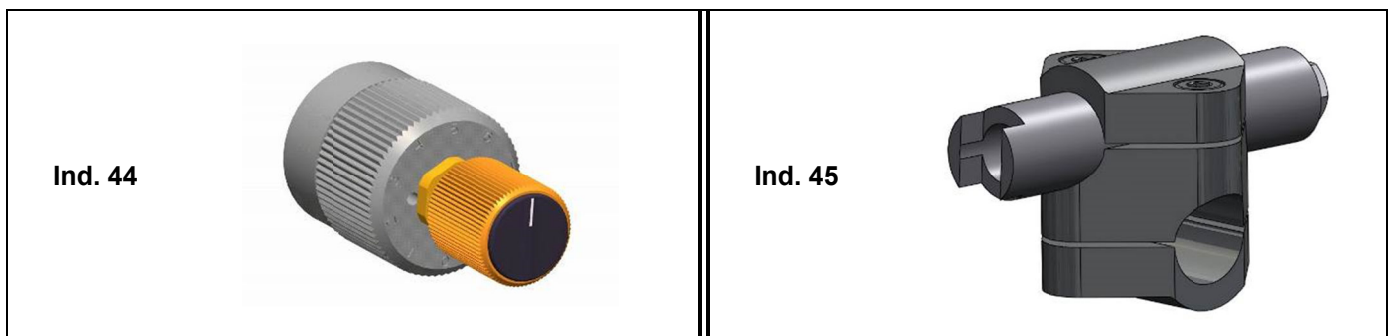

Ind	#	Désignation	Description	Bezeichnung	Denominación	Qté
44	129 713 050	Kit de réglage indexé au pointeau	Indexed needle adjust kit	Indexiertes Nadeleinstellset	Kit de regulación indexado para el botón aguja	1
45	049 351 200	Support de fixation pour pistolet (∅ 16 mm - long. 70 mm)	Gun mounting support (diameter : 16mm / 5/8" - length : 70mm / 2-3/4")	Pistolhalterung (∅ 16 - Länge 70 mm)	Soporte de fijación para pistola (∅ 16 mm - 70 mm de largo)	1
-	905 160 105	Coude M 1/8 NPT - M 1/2 JIC (arrivée produit)	Elbow M 1/8 NPT - M 1/2 JIC (fluid inlet)	Winkelnippel AG 1/8 NPT - AG 1/2 JIC (Materialeingang)	Codo M 1/8 NPT - M 1/2 JIC (entrada de producto)	1



# AUTOMATIC AIRSPRAY GUN

# PREVENTIVE MAINTENANCE

## TRANSLATION FROM THE ORIGINAL MANUAL

***IMPORTANT : Before assembly and start-up, please read and clearly understand all the documents relating to this equipment (professional use only).***

THE PICTURES AND DRAWINGS ARE NON CONTRACTUAL. WE RESERVE THE RIGHT TO MAKE CHANGES WITHOUT PRIOR NOTICE.

**SAMES KREMLIN SAS**  
13, chemin de Malacher  
38 240 - MEYLAN - France  
☎ : 33 (0)4 76 41 60 60

**[www.sames-kremlin.com](http://www.sames-kremlin.com)**

The gun is a precision instrument and it relies on good and frequent maintenance for its correct operation. If stopped for a long time, lubricate all movable parts, axes and springs with grease.

---

---

**Never use metal brushes files, points or clips for dismantling.**

---

---

▪ **SHORT DURATION SHUTDOWN**

Remove the paint on the air cap, with a brush and solvent. Otherwise, leave the equipment as it is. Removing the paint will prevent the drying and clogging of the holes.

▪ **LONG DURATION SHUTDOWN**

Shut off the gun fluid and air supply.

Depressurize the hoses by triggering the gun or by controlling the gun opening.

Unscrew the air cap. Remove the needle and then remove the fluid nozzle with the wrench provided. Soak the needle, aircap, fluid nozzle in solvent and brush them carefully, as they are precision parts.

With a brush soaked in solvent, clean the internal parts of the gun. Wash carefully brush the threaded parts.

Flush the gun.

---

---

**Do not soak the gun in solvent**

---

---



# AUTOMATIC AIRSPRAY GUN

## TROUBLESHOOTING GUIDE

### TRANSLATION FROM THE ORIGINAL MANUAL

***IMPORTANT : Before assembly and start-up, please read and clearly understand all the documents relating to the equipment (professional use only).***

THE PICTURES AND DRAWINGS ARE NOT CONTRACTUAL. WE RESERVE THE RIGHT TO MAKE CHANGES WITHOUT PRIOR NOTICE.

**SAMES KREMLIN SAS**  
13, chemin de Malacher  
38 240 - MEYLAN - France  
☎ : 33 (0)4 76 41 60 60

**[www.sames-kremlin.com](http://www.sames-kremlin.com)**



■ **DISTORTED SPRAY**

Slightly unscrew the aircap retaining ring and rotate the aircap by one half turn. If the defect is reversed, one of the lateral air holes is plugged up or deformed. Clean the gun aircap with solvent and unclog the air holes with a compressed air. If the defect is not reversed, it means that the fluid nozzle is damaged.

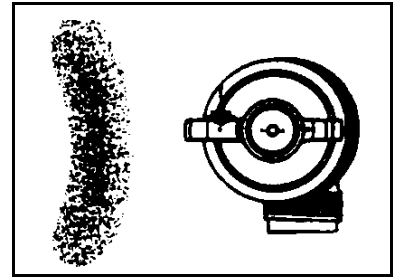

■ **DISPLACED SPRAY**

This comes from a defect in the central fan. Clean the aircap and the fluid nozzle. Make sure that :

- the aircap is correctly centered on the nozzle,
- the nozzle is not too big for the needle,
- when work is done with a large needle opening and the needle almost closed, the spray pattern is not even in all directions.

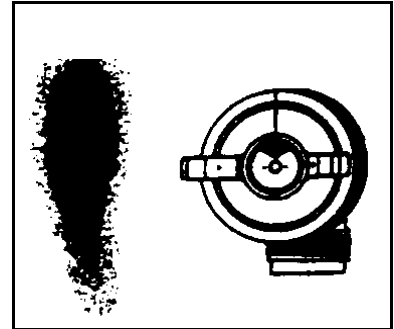

■ **FRAGMENTED PATTERN**

The fan air pressure is too big at the holes in the air cap horns :

- turn the fan air control clockwise to reduce the fan air pressure.
- increase the paint output.

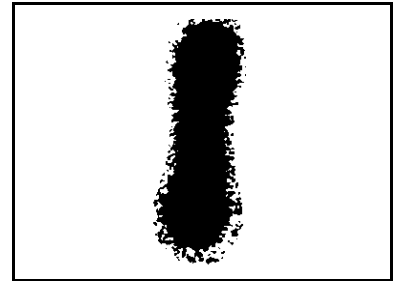

■ **FAN TOO THICK IN THE CENTER**

This is the reverse of the above defect :

- the paint output is too high for the selected air pressure :  
increase the spraying air pressure and reduce the paint output.
- if the paint is too thick, dilute it.



■ **INTERMITTANT SPRAY PATTERN**

An air inlet in the paint circuit creates an intermittant pattern when :

- the paint cup is nearly empty,
- when the nozzle is not tightened on its seat : clamp it.

If the problem persists, remove the nozzle and clean it. Check that the seat and the cone are not damaged, remount the nozzle and clamp it.

When using a cup, air can get into the paint circuit :

through the passage seal of the needle into the gun body ⇒ tighten it.

through various fittings between the gun and the cup if these are not correctly tightened.

Check that : the cup cover air hole is not blocked and the paint is homogeneous and fluid enough (use the viscosity cup).

<b>PROBLEM</b>	<b>CAUSE</b>	<b>SOLUTION</b>
No fluid out of the gun	Tip is blocked	Relieve pressure on pump. Carefully remove spray tip and filter. Take care with residual pressure in the hoses.
Pattern width narrows during reversing phase of pump	Air trapped in the fluid circuit	Check connections and suction hose quality.
	Viscosity too high	Reduce viscosity.
Aircap becomes dirty frequently	Too much air	Reduce air pressure.
	Leak from fluid packing (or cartridge)	Replace packing or cartridge.
Fluid seeping from the air holes of the aircap	Defective tip seal	Replace it.
	Tip loose	Tighten it.
Fluid leak	Impurities in the paint	Trigger the gun 3 or 4 times.
	Needle worn	Remove the needle and the nozzle.
	Cartridge or packing worn	Replace.



# AUTOMATIC AIRSPRAY GUN

***OPERATING, CONTROL AND HANDLING***

**TRANSLATION FROM THE ORIGINAL MANUAL**

***IMPORTANT : Before assembly and start-up, please read and clearly understand all the documents relating to this equipment (professional use only).***

THE PICTURES AND DRAWINGS ARE NON CONTRACTUAL. WE RESERVE THE RIGHT TO MAKE CHANGES WITHOUT PRIOR NOTICE.

**SAMES KREMLIN SAS**  
13, chemin de Malacher  
38 240 - MEYLAN - France  
☎ : 33 (0)4 76 41 60 60

**[www.sames-kremlin.com](http://www.sames-kremlin.com)**

## 1. OPERATING



### Safety instructions :

- Never try to stop the spray fan with any part of the body (hands, fingers...) or with rags. Never point the spray gun at anyone or at any part of the body.
- The operator will need medical attention if the high pressure material spray is in contact with the the body (eyes, fingers...).
- **Always lock the gun trigger with the safety device when not operating the gun.**
- **Always depressurize air and hoses** before carrying out any servicing on the gun.



In order to protect the operator, protective clothing (gloves, respirator mask, glasses, hearing protective earplug, clothes...) are required.  
Use the equipment in a properly ventilated area.

Unscrew the needle adjustment knob at the back of the gun.

Unscrew the air adjuster (s) located on the base or on the gun.

Select the desired projector (aircap + nozzle + needle) best suited for the job at hand.

Screw on the nozzle, then the aircap to the gun.

Before tightening up firmly the aircap ring, position the aircap for the best spray. The fan is vertical when the 2 ears of the aircap are horizontal.

➡ **We advice you to put the gun in the "OPEN" position to prevent any damage to the needle while fitting the nozzle.**

## 2. CONTROL

This professional spray gun features 3 controls :

### ▪ THE AIR PRESSURE

- Supply the air of the network (clean air - maximum pressure : 6 bar / 87 psi) to the gun.
- Control the gun opening (air pressure > 3 bar / 43.5 psi).
- Adjust the air pressure upstream of the gun to obtain a correct spraying.

### ▪ THE FAN WIDTH

Can be adjusted by using the knurled knob. It controls the air going to the horns on the aircap. In this way, the air is controlled through the fanned air outlets and allows the fan to change from flat (wide open) to round (closed).

### ▪ THE FLUID OUTPUT

Having selected the proper fluid nozzle / needle assembly and the fluid pressure, it is possible to further control the output by changing the travel of the needle (needle stop knob) in case of fluid supply.

Optimal set-up is usually obtained when the product needle is completely open. When this needle is nearly closed, a regular flow of product can not be guaranteed.

### 3. GUN HANDLING

When mounting the aircap on the gun, hold it vertically in order to correctly adjust the aircap before screwing the aircap ring.

Keep the gun perpendicular to the surface to be painted. Avoid working with the wrist.

Do not forget that crossed sweeps cannot correct irregularities.

Spraying from a stationary gun will not give even coverage.

Make sure that overlapping from the passes is even (gun moving vertically, part moving horizontally).

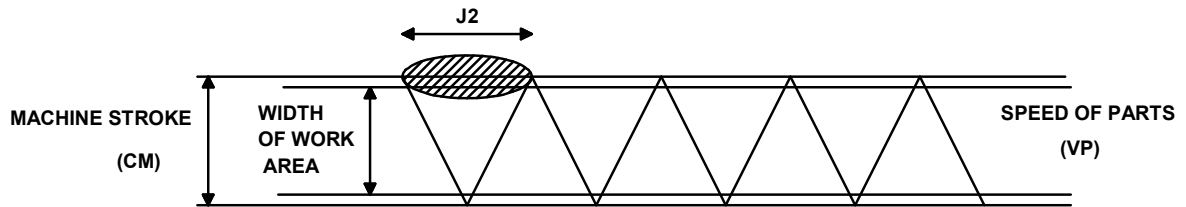

This width J2 for 2 regular coats of paint corresponds exactly to the following formula :

$$J \ 2 \ (m) = VP \ (m/s) \times 2 \ \frac{CM \ (m)}{VM \ (m/s)}$$

Where :

**VP** = speed of travel of the parts to be painted.

**CM** = total stroke of the machine (and therefore of the spray guns).

**VM** = speed of the machine (and therefore of the spray guns).

**2** = 2 regular coats of paint (or 4 if you want to double the number of coats).



## AUTOMATIC AIRSPRAY GUN

**A 3**

**TECHNICAL FEATURES**

### TRANSLATION FROM THE ORIGINAL MANUAL

***IMPORTANT : Before assembly and start-up, please read and clearly understand all the documents relating to the equipment (professional use only).***

THE PICTURES AND DRAWINGS ARE NOT CONTRACTUAL. WE RESERVE THE RIGHT TO MAKE CHANGES WITHOUT PRIOR NOTICE.

**SAMES KREMLIN SAS**  
13, chemin de Malacher  
38 240 - MEYLAN - France  
☎ : 33 (0)4 76 41 60 60  
[www.sames-kremlin.com](http://www.sames-kremlin.com)

## 1. DESCRIPTION

The A 3 spray gun is designed for applying paints and adhesives in automatic installations. It can be fitted on fixed supports, automatic machines or on robots.

It is a miniature spray guns for fine works. It enables to obtain narrow and light spray fan patterns. When using the correct projector, it allows the spraying of lines. It is an air bleedind spray gun. It is fitted with 2 fluid inlets.

## 2. TECHNICAL FEATURES

<b>Atomizing air pressure</b>	From 3 to 6 bar / from 43.5 to 87 psi
<b>Control air pressure</b>	3 bar / 43.5 psi mini
<b>Fluid pressure</b>	6 bar / 87 psi maxi
<b>Fluid flow rate</b>	Dependent upon type of nozzle (180 to 450 cm <sup>3</sup> /min)
<b>Air consumption</b>	20 m <sup>3</sup> /h maxi
<b>Operating temperature</b>	50°C / 117° F maxi
<b>Weight</b>	320 g / 70.5 lb
<b>Materials in contact with the product</b>	Aluminium - Stainless steel - Treated stainless steel

### ▪ FITTINGS

<b>Indexes</b>	<b>Spray gun</b>
Fluid (P 1)	F 1/8 NPS
Fluid (P 2)	F 1/8 NPS with plug 1/8 NPS
Control air (C)	Fitting for hose 4x6
Atomizing air (A)	F 1/8 NPS

(1)	Fan adjustment	→ fan air control
(2)	Gun mounting pin	→ support : rod Ø 16 / 5/8", length 70 mm / 2.8"
(3)	Adjustment knob	→ fluid flow rate control

▪ **DIMENSIONS**

Gun dimensions	Ind.	A	B	C	D	E	F
mm		113	65	57	38	31	38
"		5.2	2.5	2.2	1.5	1.2	2.2

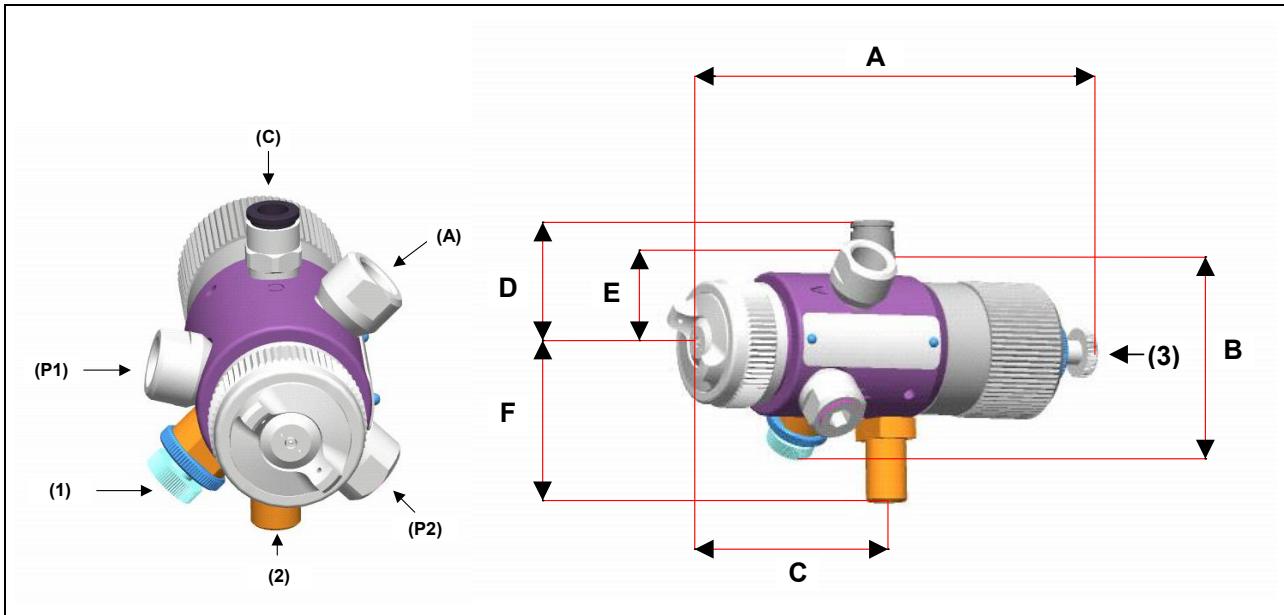

**Gun mounting support dimensions**

Ind.	G	H
mm	70	Ø 16
"	2.7	5/8

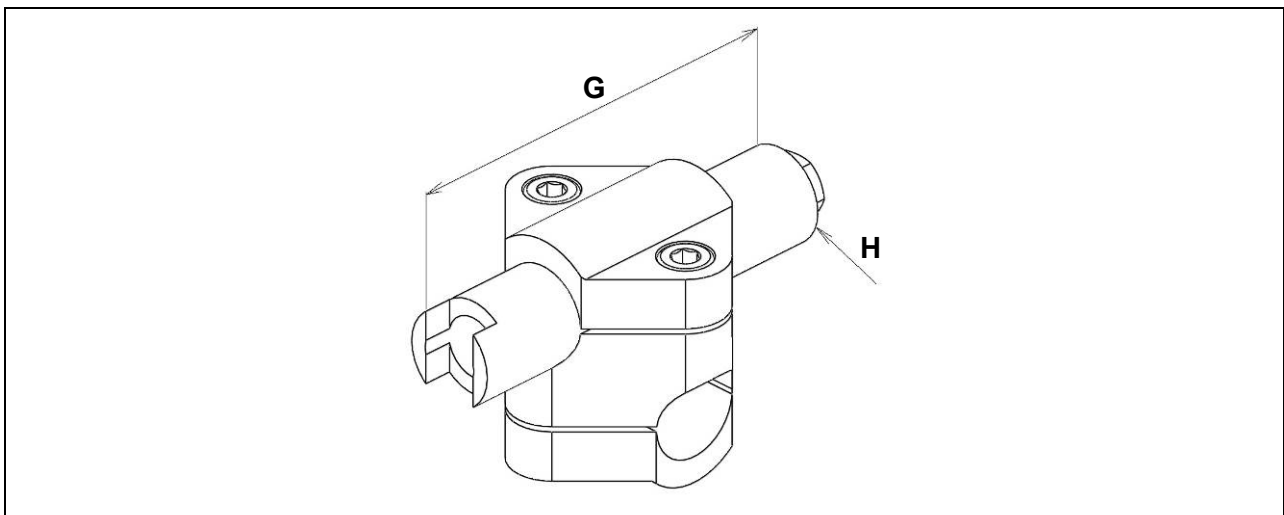





### 3. INSTALLATION

- DESCRIPTION OF THE LABEL MARKING

Marking in accordance with ATEX and UKCA regulation



Description	
<b>SAMES KREMLIN logo</b>	Manufacturer trademark
<b>A3</b>	Gun model
<b>CE</b>	<b>CE</b> : European conformity
	 : For use in explosive area <b>II</b> : group II <b>2</b> : class 2 Surface equipment meant to an area where explosive atmospheres due to gas, vapours, mists are liable to appear from time to time in usual operating. <b>G</b> : gas
<b>Ex h IIB T6</b>	<b>Ex</b> : Marking of conformity with European standards <b>h</b> : Mode of protection for non-electrical device <b>IIB</b> : Reference gas for equipment qualification <b>T6</b> : Temperature class - Maximum surface temperature : 85°C / 185°F*
<b>Gb</b>	<b>Gb</b> : Equipment protection level (Gas zone 1)
<b>X</b>	<b>X</b> : Special conditions that apply for a safe use. Refer to instructions listed in the instruction manuals accompanying your purchase.
<input type="text"/>	Marking of the manufacturer year (with 4 characters)
<b>UKCA</b>	<b>UK CA : UK Conformity Assessment</b> Marking required for certain products placed on the market in the UK
<b>P air 6 bar / 87 psi</b>	Gun air supply maximum pressure
<b>P prod 6 bar / 87 psi</b>	Maximum fluid pressure

\* Temperature class :

Temperature class	Maximum surface temperature
<b>T6</b>	85° C / 185° F