



**INSTRUCTION MANUAL**

**VOLUREX PROPORTIONING GUN  
PARKER MOTOR - JAEGER PLUGS**

<b>25 cc / 0.8 oz</b>	<b># 105 824 0406</b>
<b>50 cc / 1.7 oz</b>	<b># 105 435 0406</b>
<b>100 cc / 3.4 oz</b>	<b># 105 145 0406</b>
<b>150 cc / 5.1 oz</b>	<b># 104 115 0406</b>

**Manual : 574.094.112 - 1703**

*Date : 23/03/17 - Supersede : 21/09/12*

*Modif.: Update + § 5*

**TRANSLATION FROM THE ORIGINAL MANUAL**

**IMPORTANT : Before assembly and start-up, please read and clearly understand all the documents relating to this equipment (professional use only).**

THE PICTURES AND DRAWINGS ARE NON CONTRACTUAL. WE RESERVE THE RIGHT TO MAKE CHANGES WITHOUT PRIOR NOTICE.

**SAMES KREMLIN SAS**  
13, chemin de Malacher  
38 240 - MEYLAN - France  
☎ : 33 (0)4 76 41 60 60

**[www.sames-kremlin.com](http://www.sames-kremlin.com)**



**INSTRUCTION MANUAL  
VOLUREX PROPORTIONING GUN**

**TABLE OF CONTENTS**

<b>01. WARRANTY .....</b>	<b>2</b>
<b>02. SAFETY INSTRUCTIONS.....</b>	<b>3</b>
<b>03. DESCRIPTION .....</b>	<b>6</b>
<b>04. OPERATING PRINCIPLE .....</b>	<b>7</b>
<b>05. TECHNICAL FEATURES.....</b>	<b>8</b>
<b>06. INSTALLATION .....</b>	<b>10</b>
<b>07. MAINTENANCE .....</b>	<b>11</b>
<b>08. TROUBLESHOOTINGS.....</b>	<b>12</b>
<b>09. DISASSEMBLY - ASSEMBLY.....</b>	<b>12</b>
<b>09. EXPLODED VIEW.....</b>	<b>19</b>
<b>10. SPARE PARTS' LIST.....</b>	<b>20</b>

**ADDITIONAL DOCUMENTATIONS :**

Electric part	Doc. 574.092.110
Movable mecanic part	Doc. 574.043.110
Fixed mecanic part	Doc. 574.091.110
Pneumatic part	Doc. 574.047.110
Proportioning part	Doc. 574.045.110
Inlet valve	Doc. 574.059.110
Outlet valve	Doc. 574.159.110

Dear Customer,

You are the owner of our new equipment and we would like to take this opportunity to thank you.

To make sure your investment will provide full satisfaction, special care has been taken during all designing and manufacturing processes.

To obtain the best result, safe and efficient operation of your equipment, we advise you to read and make yourself familiar with instruction and service manual. Indeed, the non-compliance with instructions and precautions stated in this manual, could reduce the equipment working life, result in operating trouble and create unsafe conditions.

## **01. WARRANTY**

We reserve the right to make changes; these changes may be carried out after the receipt of the order. No claim will be accepted as a consequence of any change carried out in the instruction manuals or in the selection guides.

Our equipment is checked and tested prior to shipment. In the case of a problem arising with the equipment, this must be in writing, within ten days from the delivery date.

SAMES KREMLIN warrants all equipment manufactured bearing its name, to be free from defect in material or workmanship for a period of 12 months (one shift per day or 1800 hours - 1 term reached) from the date of delivery. Work life is based on single shift working - 8 hours per day. Warranty claims for defective items will only be accepted in writing and will be verified and confirmed by us.

The warranty does not cover fair wear and tear, damage or wear caused by misuse, improper maintenance or non-observance of our recommendations.

SAMES KREMLIN will repair or replace parts (carriage paid to our plant and accepted as defective by us). We shall not be liable for any losses, resulting from a production breakdown. Upon request, we can carry out service work at your premises; all expenses (travelling and accommodation) for SAMES KREMLIN technicians will be chargeable.

In the event that it is found that equipment has been tampered with, this will invalidate the warranty. Equipment that it is bought in will be subject to the suppliers' warranty.

## 02. SAFETY INSTRUCTIONS

### GENERAL SAFETY INSTRUCTIONS



**CAUTION :** The equipment can be dangerous if you do not use it according to the rules mentioned in this instruction manual. Read carefully all the instructions hereafter before operating your equipment.

#### Only trained operators can use the equipment.

The foreman must ensure that the operator has perfectly taken in the safety instructions of this equipment as well as the instructions in the manuals of the different parts and accessories.

Read carefully all instruction manuals, label markings before operating the equipment.

Incorrect use may result in injury. This equipment is for professional use only. It must be used only for what it has been designed for.

**Guards (air motor cover, coupling shields, housings,...) have been designed for a safe use of the equipment.  
The manufacturer will not be held responsible for bodily injury or failure and / or damage to property due to removal or partial removal of the guards.**

Never modify the equipment. The parts and accessories supplied must be regularly inspected. Defective or worn parts must be replaced.

#### Never exceed the equipment components' maximum working pressure.

Comply with regulations concerning safety, fire risks, electricity in force in the country of final destination of the material. Use only products or solvent compatible with the parts in contact with the material (refer to data sheet of the material manufacturer).

### PICTOGRAMS

A	D	F	E	C	G
NIP HAZARD	WARNING MOVING ELEVATOR	WARNING MOVING PARTS	WARNING MOVING SHOVEL	DO NOT EXCEED THIS PRESSURE	HIGH PRESSURE HAZARD
H	J	L	K	M	O
RELIEF OR DRAIN VALVE	WARNING HOSE UNDER PRESSURE	WEAR GLASSES OBLIGATORY	WEAR OF GLOVES IS OBLIGATORY	PRODUCT VAPOR HAZARDS	WARNING HOT PARTS OR AREAS
N	P	R	I	B	S
ELECTRICAL HAZARD	WARNING FIRE HAZARDS	EXPLOSION HAZARDS	GROUNDING	WARNING (USER)	WARNING SERIOUS INJURIES

## PRESSURE HAZARDS



Current legislation requires that an **air relief** shut off valve is mounted on the supply circuit of the pump motor to let air off when closing the supply circuit. Without this precaution, the motor residual air of the motor may let the pump beat and cause a serious injury.

Please ensure that, a **material drain valve** is mounted on the material circuit to drain it (after shutting down air to the motor and the pressure relief) before any servicing on the equipment. These valves must be closed for air and opened for product when processing.

## HIGH PRESSURE INJECTION HAZARDS

When working with high pressure equipment, special care is required. Fluid leaks can occur. Then there are injection risks in exposed parts of body that may cause severe injuries or amputations :



- Medical care must be handled immediately if product is injected under the skin or in other parts of the body (eyes, fingers).
- Never point the spray gun at any one. Never try to stop the spray with your hands or fingers nor with rags or similars.
- **Follow the shut down procedure and always depressurize air and fluid circuits** before carrying out any servicing on the gun (cleaning, checking, maintenance of the material or cleaning of the gun nozzles).
- For the guns equipped with a safety device, always lock the trigger when you do not start the gun.

## FIRE - EXPLOSION - SPARKS - STATIC ELECTRICITY HAZARDS



A poor earth connection, inadequate ventilation, sparks or static electricity can cause an explosion or fire. to avoid these risks when using or servicing SAMES KREMLIN equipment, the following safety procedures must be followed :

- ensure a good earth connection and ground the parts to be handled i.e. solvents, materials, components and equipment,
- ensure adequate ventilation,
- keep working area clean and free from waste solvents, chemicals, or solid waste i.e. rags, paper and empty chemicals drums,
- never use electrical switches / power if in an atmosphere of volatile solvent vapour,
- stop working immediately in case of electrical arcs,
- never store chemicals and solvents in the working area.

## TOXIC PRODUCT HAZARDS



Toxic products or vapours can cause severe injury not only though contact with the body, but also if the products are ingested or inhaled. It is imperative :

- to know the material products and their risks,
- notified or hazardous materials must be stored in accordance with the regulations,
- the material must be stored in an appropriate container, never place materials in a container where there is a risk o spillage or leakage,
- a procedure must be applied for the safe disposal of waste material. It must comply with all prevailing regulations and legislations of the country where the equipment is to be used,
- protective clothing should always be worn in compliance with the material manufacturers' recommendations,
- depending on the application and chemical safety instructions, safety glasses, hearing protective earplug, gloves, foot wear, protective masks and possible breathing equipment should be worn to comply with the regulations

(Refer to chapter "Safety equipment of SAMES KREMLIN selection guide).



### CAUTION!

It is forbidden using any solvent or with halogenated hydrocarbon base and also products with these solvents facing **aluminium** or **zinc**. The non-compliance with the instructions may cause explosion hazards causing serious or fatal injuries.

### EQUIPMENT REQUIREMENTS

**Guards (air motor cover, coupling shields, housings,...) have been designed for a safe use of the equipment.**  
**The manufacturer will not be held responsible for bodily injury or failure and / or damage to property due to removal or partial removal of the guards.**

### PUMP

Before carrying out any work, it is imperative to get used with the compatibilities of motors with pumps before coupling. The operator shall understand the equipment and the safety instructions. These instructions are available in the manuals of the pumps.



The air motor is designed to be mounted with a pump. Never modify any components or couplings. Where operating, please keep hands away from moving parts. Before starting up the equipment, please read the PRESSURE RELIEF instructions. Please ensure that any relief or drain valves fitted are in good working order.

### HOSES

- Keep hoses out of circulation areas, moving parts or hot surfaces,
- Never expose product hoses to temperature higher than + 60°C / 140° F or lower than 0°C / 32° F,
- Never pull or use the hoses to move the equipment,
- Tighten all fittings as well as the hoses before operating the equipment,
- Check the hoses regularly; change them if they are damaged,
- Never exceed the maximum working pressure (MWP) indicated on the hose.

### USED PRODUCTS

Considering the variety of products that may be used by the users and the impossibility to check off all chemical data, of possible reactions of chemicals to each other and their long term evolution, SAMES KREMLIN can not be considered as liable for :

- the bad compatibility of wetted parts,
- risks for staff and surroundings,
- for worn or out of order parts, for wrong working of equipments or units, as well as for the qualities of final product.

The user must know and prevent the possible risks as toxic vapours, fires or explosions due to used products. He shall determine the risks of immediate reactions or pursuant to repeated exposures of the staff.

SAMES KREMLIN shall not be liable for psychic injuries, direct or indirect material damages further to the use of chemicals.

## ENVIRONMENT

### Label marking on the Volurex proportioning system

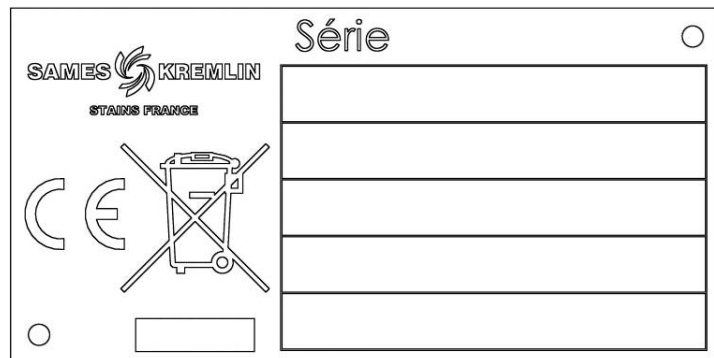

This equipment consists of a label plate with the name of the manufacturer, the equipment part number, the interesting informations to use correctly the equipment (pressure, voltage...) and the above pictogram.

The equipment is designed with and consists of high quality materials and components which can be re-used.

The 2012/19/UE European Directive covers all equipments with a crossed-out bin pictogram. Please inform yourself about the collection systems for electric and electronic equipments.

Please according to local rules and **do not throw the old equipments with household wastes**. A correct disposal of the old equipment will help prevent negative consequences for the environment and health.

## 03. DESCRIPTION

The VOLUREX system consists of a Volurex proportioning gun and a control bay. It is designed for dispensing materials beads (silicone, adhesive, mastic...) for cold and hot extrusion.

The VOLUREX assembly is linked to a robot that ensures the displacement of the proportioning system (or of the part). The robot sends a signal to the control bay, thus providing the flow rate required to dispense the bead.

The flow rate as well as the dosing are programmable and electronically controlled thanks to the control bay.

Depending upon the external informations (robot, manipulator, proportioning system), the bay drives the system. It controls some safety devices that protect the proportioning system and its environment.

## 04. OPERATING PRINCIPLE

The proportioning system consists of :

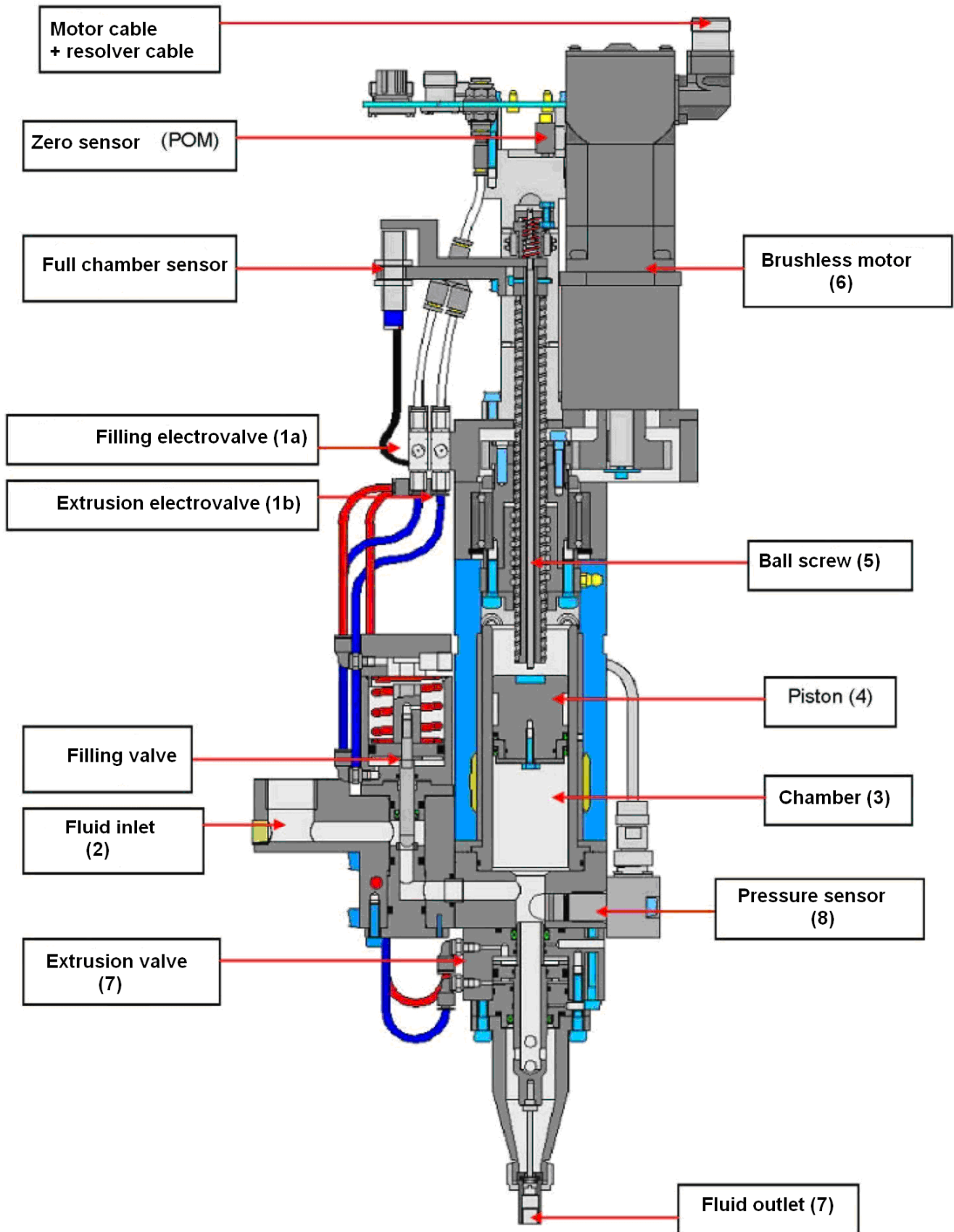



The dispensing system consists of 3 actuators :

- The motor (6) of the proportioning system gives a translation motion to the piston (4) via the ball screw (5)
- The electrovalve (1a) enables the material coming from the fluid inlet (2) to enter into the chamber.
- The electrovalve (1b) enables the material from the chamber (3) to be extruded via the fluid outlet (7).

## ■ OPERATING

### **First position :**

- The piston (4) is downwards and the ball screw (5) upwards.

### **Filling :**

- The filling electrovalve (1a) opens to let the material enter in via the fluid inlet (2).
- The fluid enters in the chamber (3) via the shutting group (not represented).
- The piston (4) goes up because of the fluid until coming into contact with the ball screw (5).

### **Pressurization :**

- Thanks to the pressure sensor (8), the piston (4) goes down to put the fluid to the required pressure.

### **Extrusion :**

- The extrusion electrovalve (1b) opens to let the material enter in via the fluid outlet (7).
- The piston (4) goes down in the chamber (3) with a speed that fits in with the output selected by the robot.
- The volume applicated is calculated thanks to the stroke carried out by the piston (4).

### **Drain :**

The drain consists in :

- carry out an extrusion (empty the gun chamber) during a long duration shutdown of the proportioning system or during a request of the operator.
- then carry out a filling operation (fill the gun chamber with material).

## 05. TECHNICAL FEATURES

### ■ DIMENSIONS

	<b>A</b>	<b>B</b>	<b>C</b>	<b>D</b>	<b>E</b>	<b>F</b>	<b>G</b>	<b>H</b>	<b>I</b>
mm	182	654	60	82	12	Ø 8	224	207	50
"	7.2	25.7	2.4	3.2	0.5	5/16	8.8	8.1	2
	<b>J</b>	<b>K</b>	<b>L</b>	<b>M</b>	<b>N</b>	<b>O</b>	<b>P</b>	<b>Q</b>	<b>R</b>
mm	10	52	110	120	182	67	40	188,45	142
"	0.4	2.05	4.3	4.7	7.2	2.6	1.6	7.4	5.6
	<b>S</b>								
mm	154								
"	6.1								

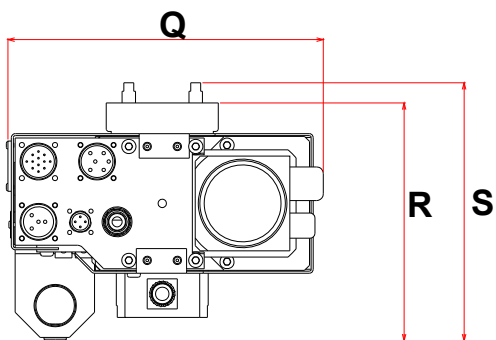
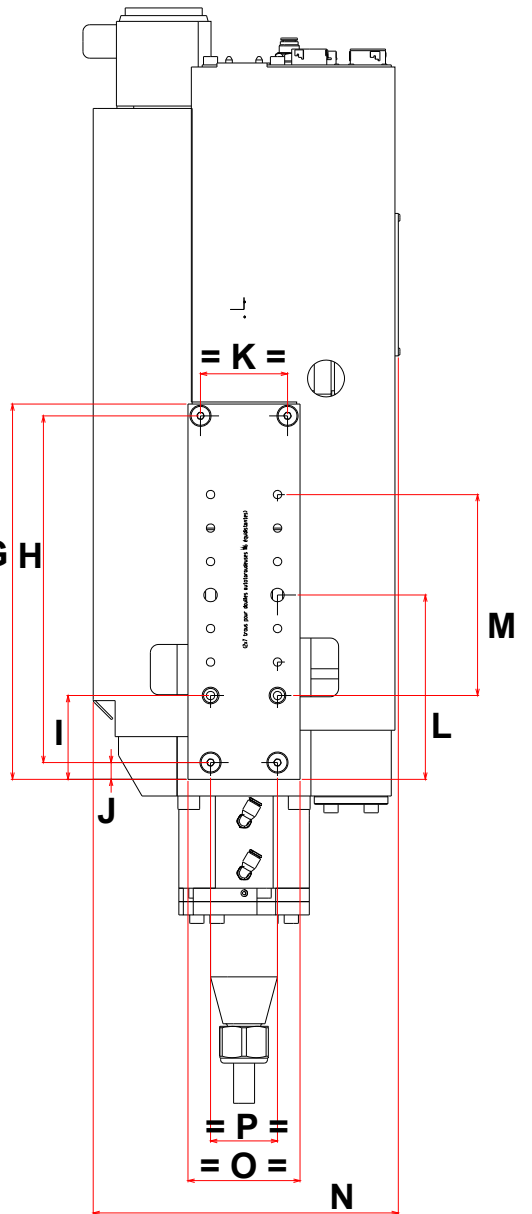
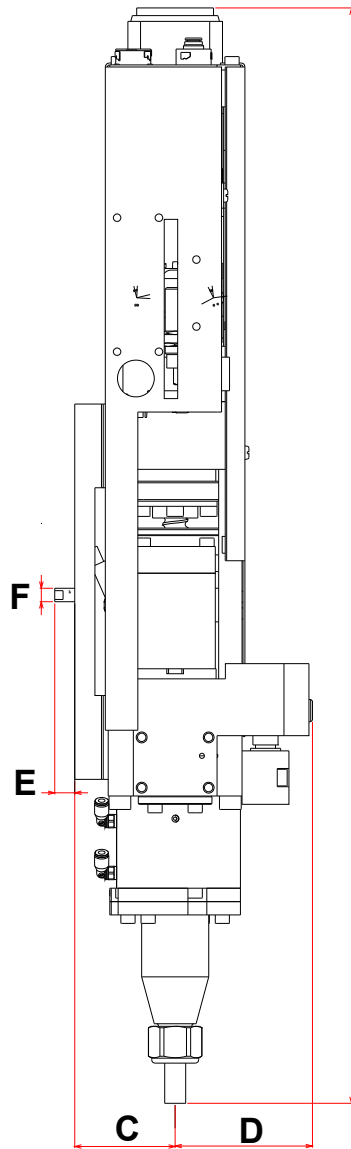
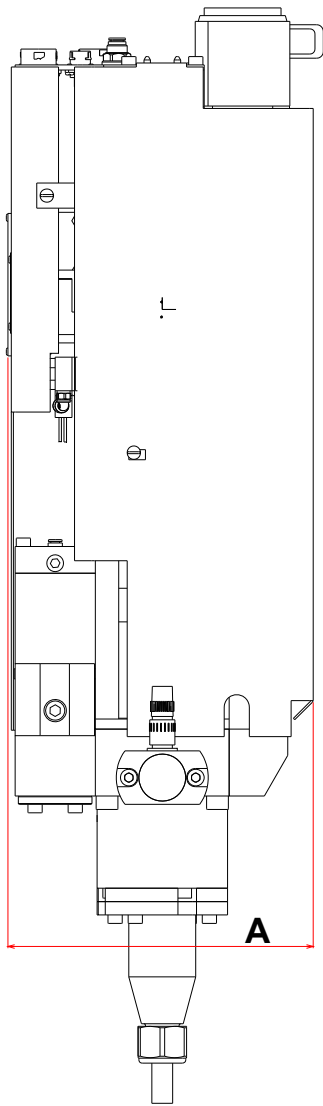

## ■ FEATURES

The VOLUREX can apply materials which have viscosities from 2 000 up to 1 000 000 Cps.

	VOLUREX			
	25	50	100	150
Capacity (cm <sup>3</sup> / oz)	25 / 0.8	50 / 1.7	100 / 3.4	150 / 5.1
Maximum fluid output (cm <sup>3</sup> /mn)	195	362	726	1090
Fluid application	Hot extrusion			
Maximum filling product pressure (bar / psi)	200 bar / 2900 psi			
Outlet dismantling product pressure (bar / psi)	200 bar / 2900 psi	170 bar / 2465.5 psi	85 bar / 1233 psi	60 bar / 870 psi
Air pressure (valve)	5 bar / 72.5 psi			
Motorization version	Parker			
Pressure sensor	0-200 bar / 0-2900 psi			
Maximum fluid temperature	80°C / 176° F			
Weight	12 kg / 26.5 lb		13 kg / 28.7 lb	
<b>Fluid connections</b>				
Fluid inlet (inlet valve)	F 3/4" BSP			
Fluid outlet (outlet valve)	Threading F10x100			
Nozzle (option)	Ø from 0.8 to 8			
<b>Electric features</b>				
Voltage (V)	230			
Power (W)	515		555	575
Intensity (A)	1,11			
Frequency (Hz)	50			
<b>Electric connections</b>				
Connectors	Jaeger			
Electric resistances	3 resistances of 125W - 230V (1 → inlet valve, 1 → outlet valve, 1 → proportioning system body)			
Heated collar (proportioning part)	140 W		160 W	
Temperature drill	PT 100 (located in the proportioning system body)			

## 06. INSTALLATION

### ■ PNEUMATIC CONNECTIONS

Install a HP fluid hose between the mastic regulator fluid inlet and the VOLUREX proportioning system inlet valve. The hose can be heated one to make easier the fluid flow.

Install an air hose (Ø 4x6) to supply with compressed air the proportioning system. Connect it to the compressed air network by means of a regulator.

### ■ ELECTRIC CONNECTIONS

Connect the electric cables between the control bay and the proportioning system.

Connect the interface electric cables between the control bay and the robot control box.

Connect the control bay to the network.

## 07. MAINTENANCE

**Guards (air motor cover, coupling shields, housings,...) have been designed for a safe use of the equipment.**  
**The manufacturer will not be held responsible for bodily injury or failure and / or damage to property due to removal or partial removal of the guards.**

### ■ DAILY PREVENTIVE MAINTENANCE

Be certain the hoses are in good condition and that there is no leakage.

Drain the proportioning gun after a long duration shutdown.

Check the nozzle is clean and correctly tightened. Clean it or change it (clogging or bead fault).

### ■ MONTHLY PREVENTIVE MAINTENANCE

Check if there is air or fluid leakage at the inlet and outlet valves' level (fluid leakage detector).



**Lubricate the ball screw (every 300 hours)**  
(KLUBER grease - STABUTHERM GH 461)  
(ball screw life duration: 500 000 cycles)

**NEVER TAKE OFF THE BALL SCREW FROM THE NUT**

**Lubricate the needle stop (KLUBER grease - STABUTHERM GH 461)**

2 lubricators (one located on the fixe part, the other one on the movable part of the proportioning system) enable to lubricate the ball screw and the needle stop. Remove the carter to carry out the lubrication.

### ■ BIMONTHLY PREVENTIVE MAINTENANCE

Check the tightening :

- of the inlet valve on the body,
- of the outlet valve on the body.

Check there is no fluid leak coming from the piston of the proportioning part.

### ■ YEARLY PREVENTIVE MAINTENANCE

Remove, clean the inlet valve. Change the seals.

Remove, clean the outlet valve. Change the seals.

Remove, clean the proportioning part. Change the seals.

Check the piston.

Check the ball screw and the bearings.



**When reassembling :**

- **Lubricate the ball screw, the needle stop, the slides and the bearings (KLUBER grease - STABUTHERM GH 461)**
- **Lubricate the seals, the piston, the cylinder, the needle (PTFE MAGNALUBE grease) (refer to § 11)**

*Nota : if using intensively the equipment, the maintenance frequency could be modified.*

## 08. TROUBLESHOOTINGS

If a trouble occurs during the operating of the VOLUREX proportioning system, the fault will be displayed on the bay display unit (refer to bay instruction manual).

## 09. DISASSEMBLY - ASSEMBLY

**Guards (air motor cover, coupling shields, housings,...) have been designed for a safe use of the equipment.  
The manufacturer will not be held responsible for bodily injury or failure and / or damage to property due to removal or partial removal of the guards.**

### ■ DISASSEMBLY / ASSEMBLY OF THE COMPLETE PROPORTIONING SYSTEM

#### **Disassembly :**

Empty completely the proportioning system,  
Shut off the air supply of the pump into operation,  
Switch the 'AUTO MANU' control box switch on 'MANU'.  
Drain the proportioning system.  
Open the drain valve (pump or collector).  
Switch off the proportioning system.  
Disconnect the beads of the electric connection.  
Remove the VOLUREX proportioning gun.

#### **Assembly :**

Install the new proportioning system,  
Connect the fluid supply hose on the inlet valve,  
Connect the electric connectors,  
Switch the heat area on 'ON'.  
Close the drain valve (pump or collector),  
Install air on the pump motor,  
Drain the circuit (pump, hose, proportioning system) until there is no more air,  
Switch the 'AUTO MANU' control box switch on 'AUTO'.

#### **To remove a component from the proportioning system, you must :**

- Stop the installation (depressurize, drain),
- Shut off the electric and pneumatic supply,
- Take off the 2 carters.

### ■ CHANGING THE INLET VALVE

Remove the hose located upwards the inlet valve,  
Disconnect the 2 air hoses (red and blue),  
Unscrew the 4 screws that hold the inlet valve on the proportioning system (BTR wrench n° 5),  
Take off the inlet valve.  
On the new valve, lubricate the seal in contact with the proportioning system body.  
Install the new valve, slide it on the heated resistance, then tighten the 4 screws.  
Install the fluid supply hose and the air hoses.  
Red hose → top fitting (closing of the valve)  
Blue hose → low fitting (opening of the valve)  
Place the installation into operation.

🔄 To disassemble / assemble the valve, refer to 'INLET VALVE' documentation.

#### ■ CHANGING THE OUTLET VALVE

Disconnect the 2 air hoses (red and blue).

Unscrew the 4 screws that hold the outlet valve on the proportioning system (BTR wrench n° 5).

Remove the outlet valve.

On the new valve, lubricate the seals in contact with the proportioning system body.

Install the new valve, make the heated resistance slide on the hole expected (shoulder hole, model Ø 5 mm), then tighten the 4 screws.

Connect the air hoses.

Red hose → low fitting (closing of the valve)

Blue fitting → top fitting (opening of the valve)

Place the installation into operation.

🔄 To disassemble / assemble the valve, refer to 'OUTLET VALVE' documentation.

#### ■ DISASSEMBLY / ASSEMBLY OF THE PROPORTIONING PART

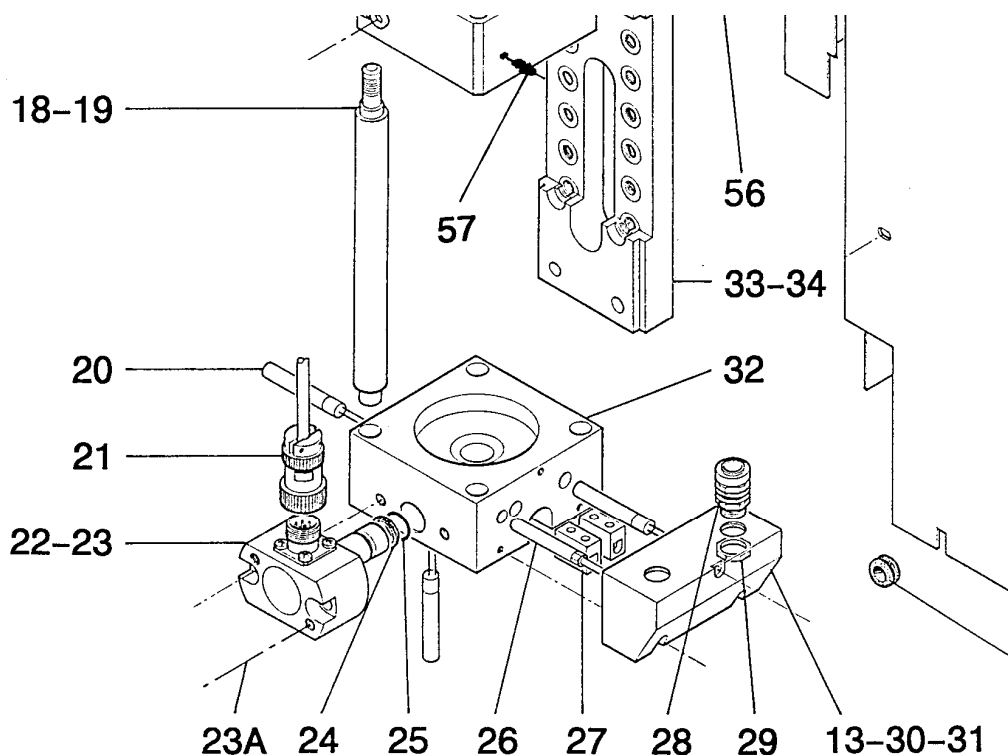

Remove the inlet valve and the outlet valve of the proportioning system.

Disconnect the pressure sensor (22). Unscrew the screws (23) (BTR wrench n° 5) and **screw** the 2 extraction screws (23A) (BTR wrench n° 3).

Remove the electric box (30).

To remove the resistances (20) and the temperature drill (26) located in the proportioning system body (32), unscrew the screw of the rope-thimble (BTR wrench n° 3).

Unscrew the 2 screws (34) that hold the fixing plate (33) and the proportioning system body (32) (BTR wrench n° 4).

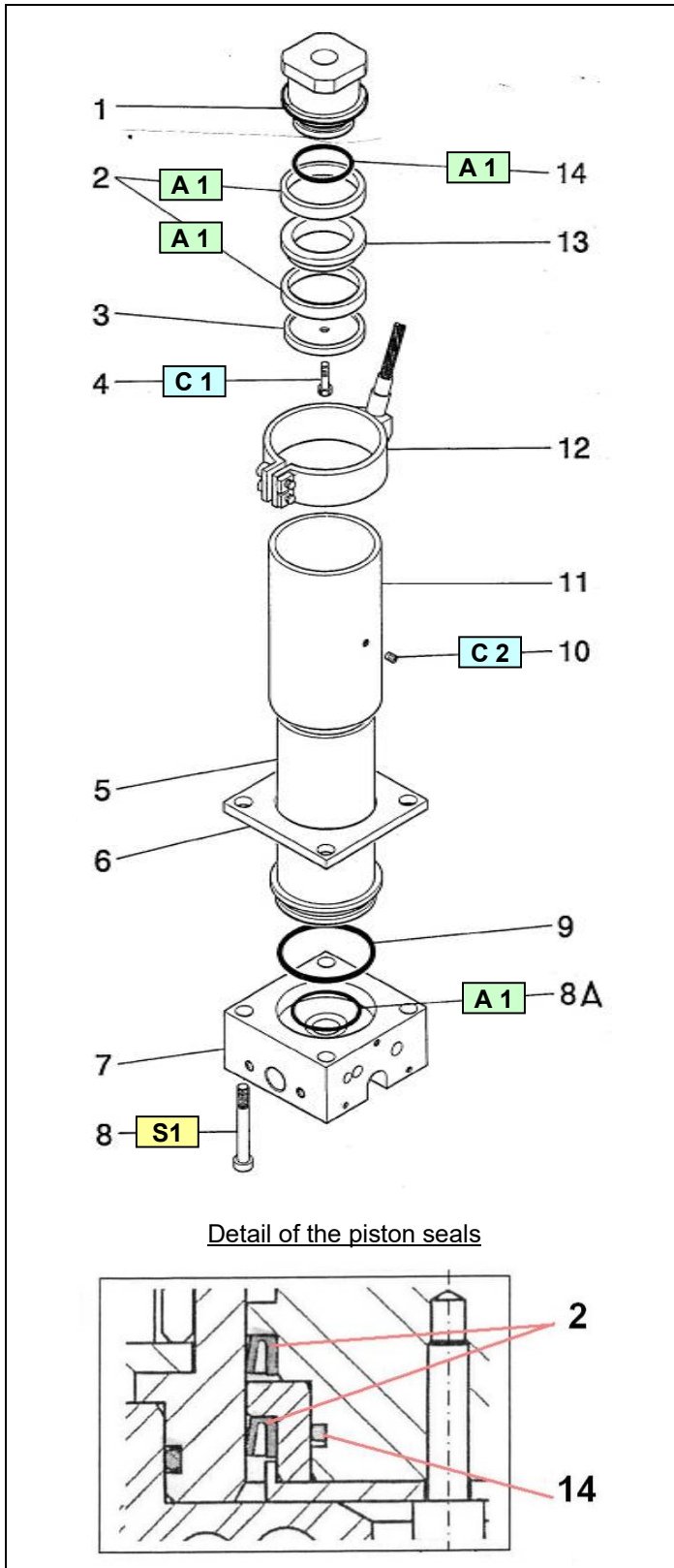

On the proportioning part :

Unscrew the little screw (10) located at the middle of the heated collar (12).

Take off the 4 screws (8) that hold the proportioning part.

Make the body (7), the cylinder (5), the piston assembly slide backwards.

Do not remove the sleeve (11) and the heated collar (12).

Take off the piston and change the seals (2, 14).

#### **Assembly :**

Grease the seals (2, 9, 14) and the seal for the 25 cc Volurex proportioning system.

On the piston (1), install the seal (14), a seal (2), the ring (13), the second seal (2), the stop washer (3) - refer to above drawing.

Applicate Loctite 577 glue on the threading of the screw (4) and tighten the whole with that screw.

Grease the inside of the cylinder (5) and install the piston assembly on that cylinder.

**Important : Make it slide from downwards to upwards to prevent from damaging the piston seals.**

Install the counter plate (6).

**Caution when mounting the plate (5) → shoulder downwards.**

Install the seals (9 & 8A) at the bottom part of the cylinder (5).

Slide the whole in the sleeve (11).

Applicate Loctite 222 glue on the screw (10).

Tighten the whole (11 & 12) on the cylinder (5) with the screw (10).

Reinstall the body (7) at the bottom part of the cylinder (5).

(Locate the 2 holes of the body in front of the 2 holes of the fixing plate (33)).

Tighten (16 Nm / 11.802 Ft/Lbs) the screws (8) in the 4 tie-rods (ind. 18 of the fixing part).

Connect the heated collar.

Reinstall the different components : the electric box, the pressure sensor, the inlet valve and the outlet valve.

Place the installation into operation.

## ■ CHANGING THE MOTOR

Stop the installation (depressurize, drain, disconnect).

Disconnect the 2 cables connected to the motor (power and control).

Unscrew the 4 screws that hold the motor (48) (BTR wrench n° 4).

Remove the motor.

Remove the motor pinion (27) unscrewing the screw (BTR wrench n° 3) and the plate on which it is screwed (BTR wrench n° 4).

Change with a new motor and connect the 2 cables.

Place the installation into operation.

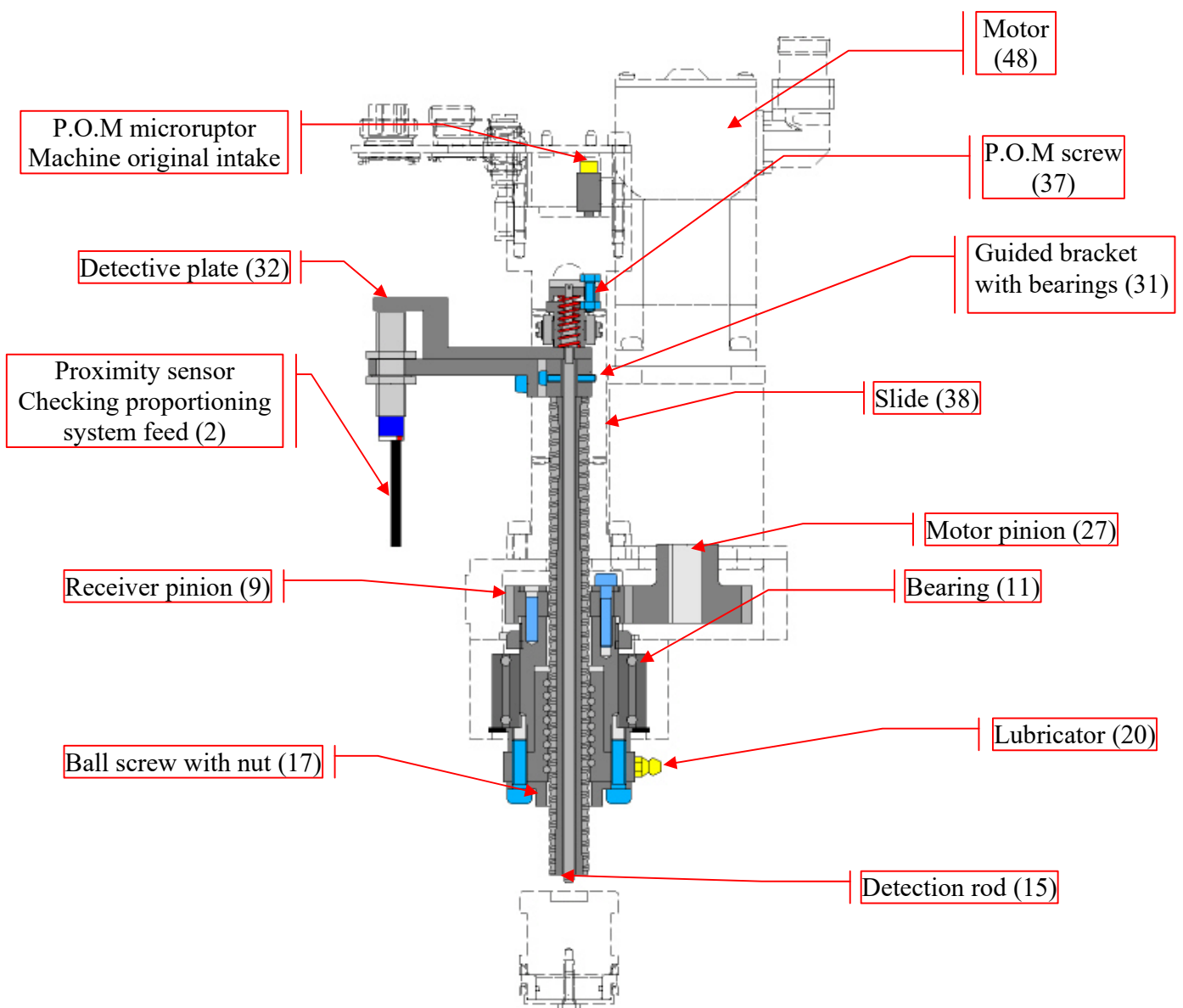
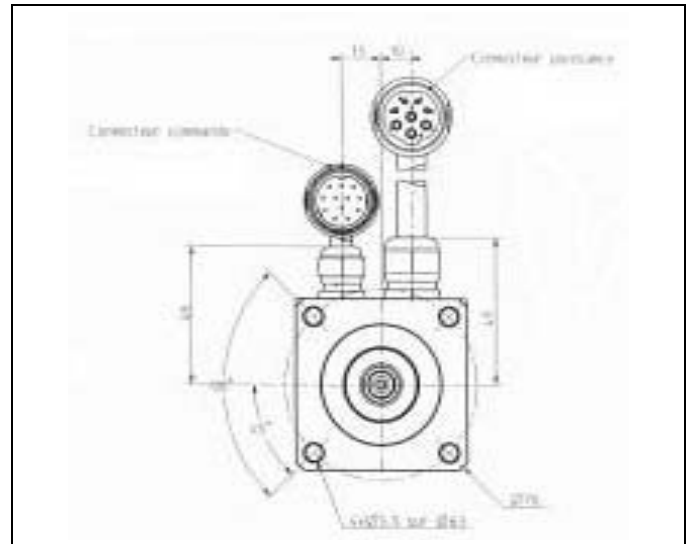



## ■ CHANGING THE BALL SCREW (IND. 17)

Remove the inlet valve, the outlet valve, the proportioning part (do not remove the sleeve and the heated collar).

Unscrew the 2 screws (30) (BTR wrench n° 2.5) installed on the bracket (31).

Unscrew the 4 screws (18) (BTR wrench n° 5) installed on the stop (19).

Hold the whole to prevent it from rotating.

Take off the ball screw pushing it downwards.

During the disassembly, check if there is play in the bearings.



**Lubricate the ball screw**  
(KLUBER grease - STABUTHERM GH 461)

**NEVER TAKE OFF THE BALL SCREW FROM THE NUT.**

Install the new ball screw, the stop (19). Tighten them with the screws (30 & 18).

Reinstall the proportioning part, the outlet valve and the inlet valve.

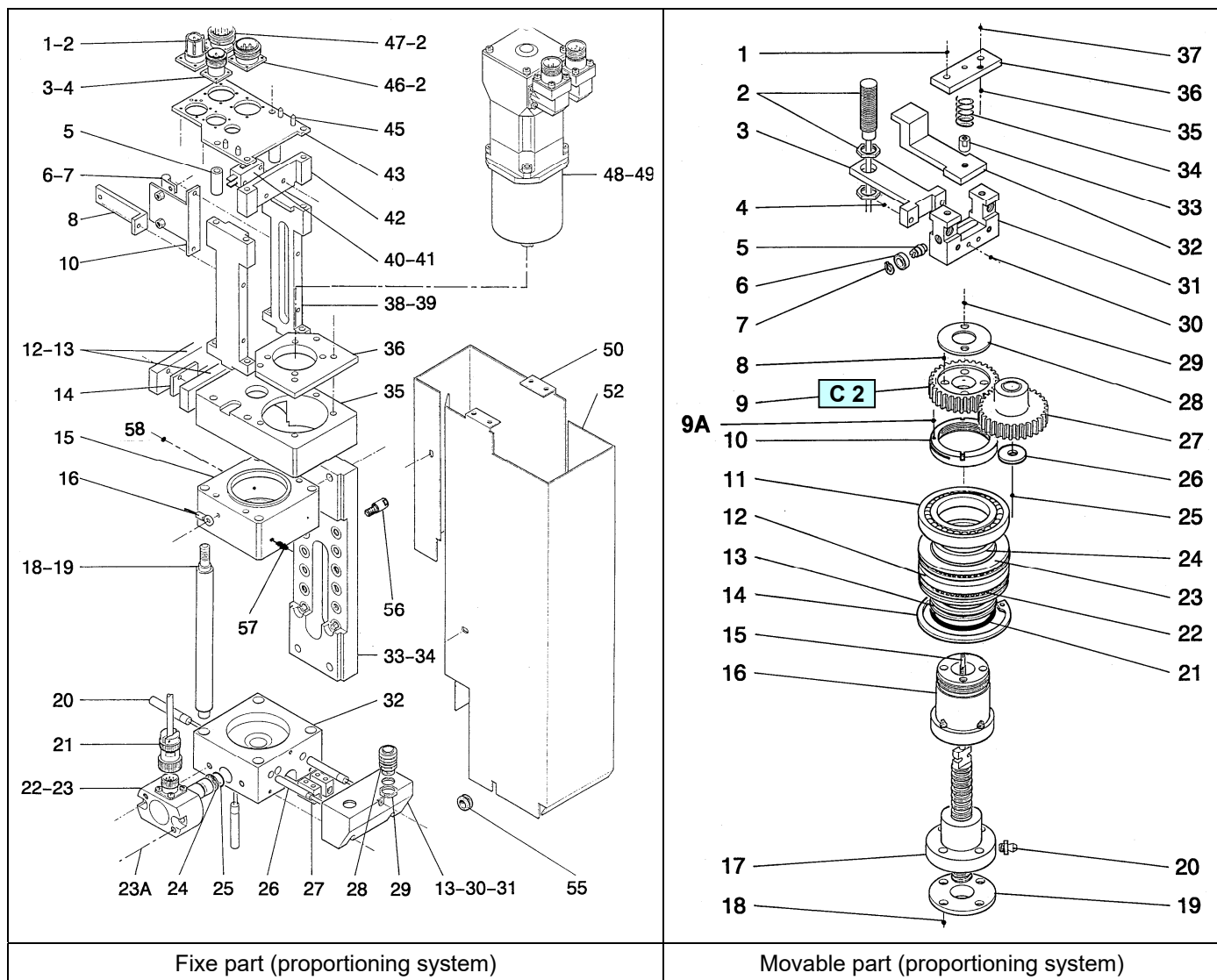

## ■ CHANGING THE BEARINGS (11), THE NEEDLE STOP (22)

Take off the 4 tie-rods (18).

Take off the screws (34) that hold the bearing box (15) on the fixing plate (33).

The whole (A) consists of the bearing box, the ball bearing (11), the needle stop (22), the spacers (13, 24), the washers (12, 23), the bearing shaft (16), the ring (14).

Nota : the pinion (9) does not take part from the whole (A).

Disassemble the receiver pinion (9) from the bearing box.

Unscrew the 2 screws (29) (BTR wrench n°4) to remove the washer (28).

Take off the 2 pins (8), the pinion (9).

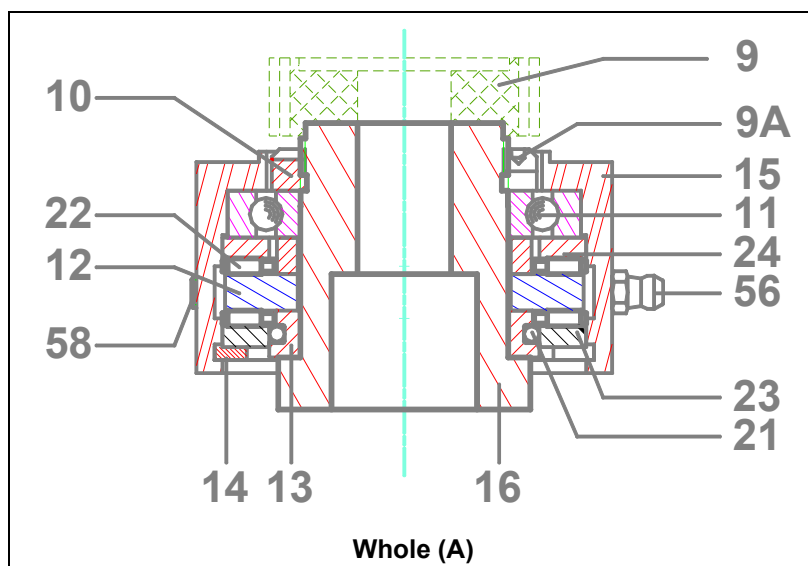

Change the whole (A). Reinstall the receiver pinion (9), the 2 pins (8), the washer (28) and the 2 screws (29).

⚠ **Caution : comply with the pinion and washer assembly orientation.**



**To lubricate the bearings and the needle stop, apply grease on the lubricator (56).**

Install the new assembly in the proportioning system.

Make the assembly turn by hand before assembling the other components (tie-rods, ball screw...).

## ■ CHANGING THE POM SENSOR (40)

Take off the connection plate (43) unscrewing the screws at the back.

Unscrew the screws (41).

Take off the electric rope-thimbles.

Take off the sensor (40).

Install a new sensor instead of it.

Connect the electric rope-thimbles (terminals 1 & 2).

## ■ CHANGING THE MEASURE ROD (15)

Remove the sensor bracket (42).

Unscrew the screws to take off the 2 spacers (5).

Unscrew the 2 screws (39) (BTR wrench n° 4).

⚠ Take off the slide (38), opposite side of the cable bracket.

Remove the bracket (31) and the detection rod (15).

You can change the little bearings (6) removing the clips (7).

⚠ Lubricate the bearings during the assembly.

To change the rod (15) :  
 Unscrew the screws (1).  
 Remove the plate (36), the spring (34).  
 Unscrew the nut (33).  
 The rod is screwed in the detection plate (32).

**⚠ When reassembling, comply with the 213 mm / 8.4" dimensions between the end of the rod (15) and the detection plate (32).**

Applicate glue on the threading of the rod (Loctite 577).

Reinstall the nut (33), the spring (34), the plate (36) (36), the 2 screws (1).

**Check the 5 mm / 0.2" dimension between the screw (37) and the plate (36).**

Lubricate the slides (38).

Reinstall the slides and the cart (rod with plate).

Tighten the screws by hand.

Locate the cart downwards and tighten the bottom of the slides by means of clamps.

Tighten the screws by means of the wrench.

Install above the plate with the connectors.

Displace the clamps upwards of the slides and tighten the upper screws.

**⚠ Displace the cart checking that the bearings turn.**

Lubricate the rod (15) and reinstall the ball screw (17).

Insert them in the bracket (31).

**⚠ Line up the different parts.**

Install the plate (19) at the bottom of the ball screw and tighten it with the screws (18).

Reinstall the proportioning part, the outlet valve and the inlet valve.

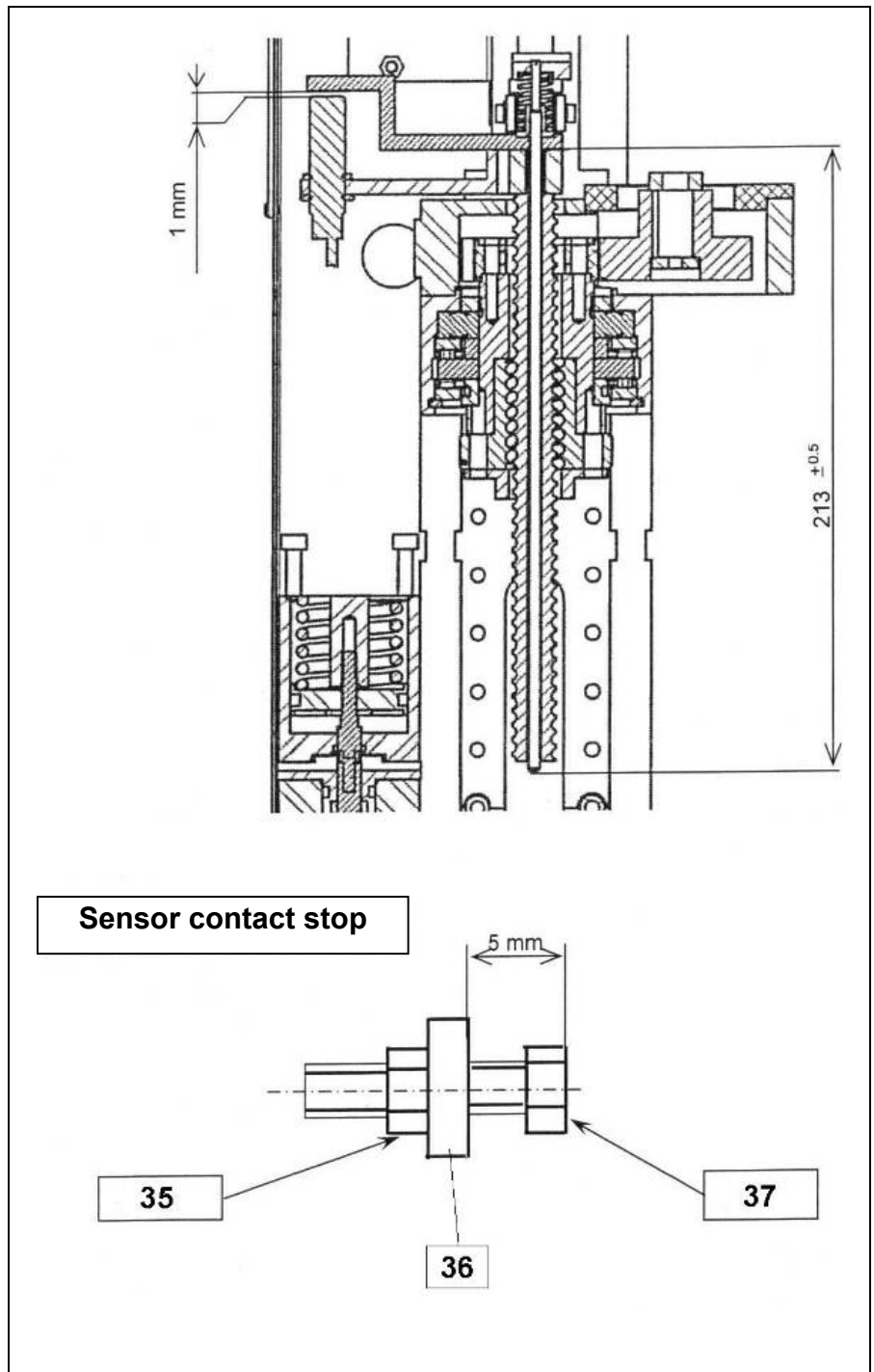

## ■ CHANGING THE ELECTROVALVES

Disconnect the electrovalves.

Change them.

EV controls the outlet valve that is bellow (cable with a black coupling).

EV controls the outlet valve that is above (cable with a white coupling)

Index	Instructions	Description	Part number
A 1	PTFE Grease	"TECHNILUB" grease (10 ml)	560.440.101
C 1	Medium strength Aneorobic Pipe sealant	Loctite 577 (250 ml)	554.180.015
C 2	Low strength - Aneorobic Adhesive	Loctite 222 (50 ml)	554.180.010
S 1	Torque screwing : 16 Nm / 11.802 Ft/Lbs		

## 09. EXPLODED VIEW

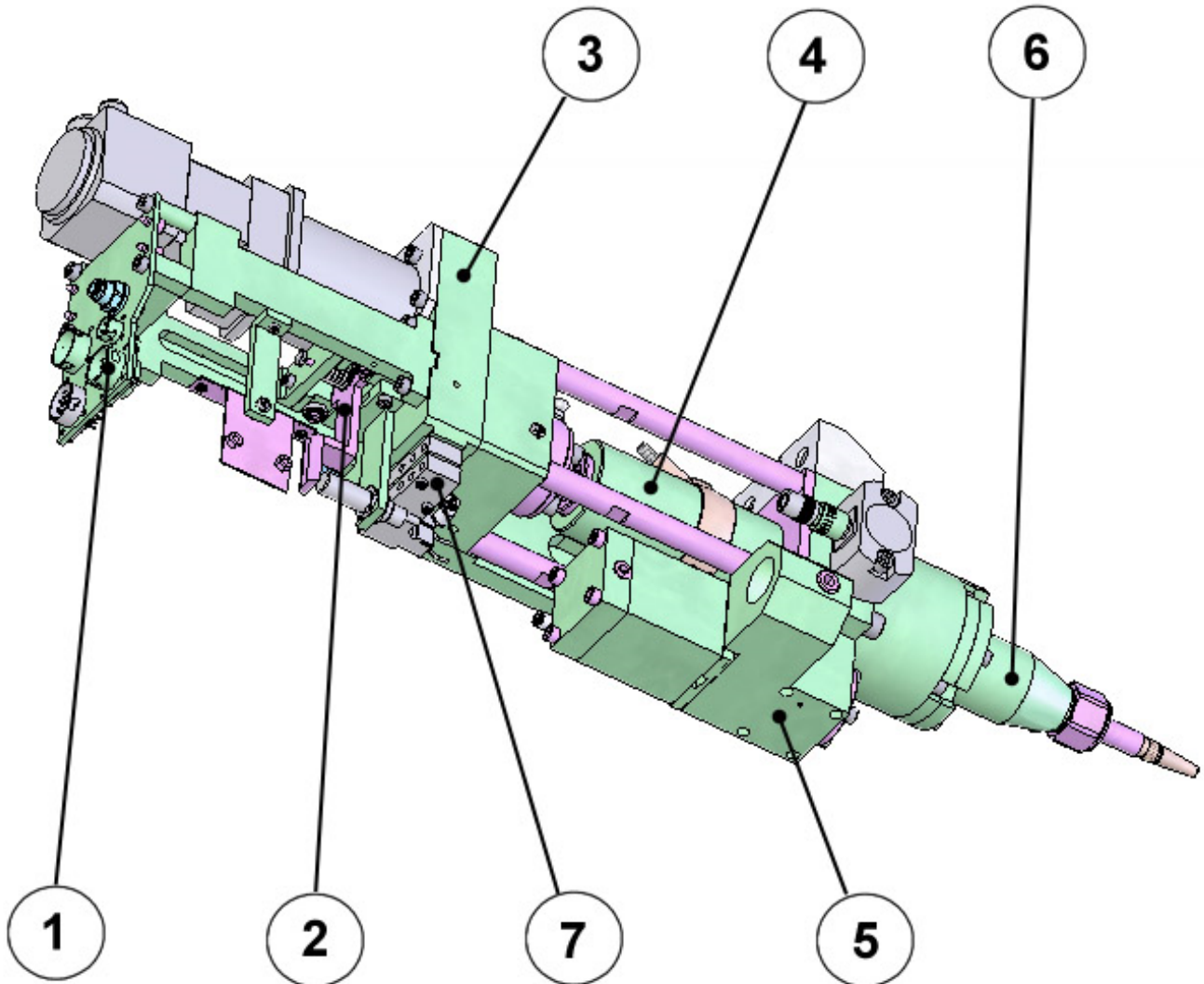

## 10. SPARE PARTS' LIST

<b>VOLUREX PROPORTIONING SYSTEM</b>	<b>25</b>	<b>50</b>	<b>100</b>	<b>150</b>
<b>#</b>	<b>105 824 0406</b>	<b>105 435 0406</b>	<b>105 145 0406</b>	<b>104 115 0406</b>

Ind	#	Désignation	Description	Bezeichnung	Denominación	Qté
1	106 593	Partie électrique	Electric part	Elektrisches Teil	Parte eléctrica	1
2	105 806	Partie mécanique mobile	Movable mechanical part	Bewegliches mechanische Teil	Parte mecánica móvil	1
3	106 592	Partie mécanique fixe	Fixed mechanical part	Befestigtes mechanische Teil	Parte mecánica fija	1
*4	-	Partie dosage (voir pièces spécifiques)	Proportioning part (see specific parts)	Dosierungsteil (Siehe spezifische Teile)	Parte dosificación (ver partes específicas)	1
*5	107 139	Vanne d'entrée	Inlet valve	Eingangsventil	Válvula de entrada	1
*6	107 202	Vanne de sortie	Outlet valve	Ausgangsventil	Válvula de salida	1
7	104 159	Partie pneumatique	Pneumatic part	Pneumatisches Teil	Parte neumática	1

### *Pièces spécifiques - Specific parts - Spezifische Teile - Partes específicas*

Partie dosage / Proportioning part / Dosierungsteil / Parte dosificación				
Ind	Volurex 25	Volurex 50	Volurex 100	Volurex 150
*4	# 104 471	# 104 357	# 104 198	# 104 057

Voir les documentations séparées / See separated documentations /  
 Siehe die zusätzlichen Bedienungsanleitungen / Ver las documentaciones separadas

### *Option - On request - Optionen - Opción*

Ind	#	Désignation	Description	Bezeichnung	Denominación	Qté
-	560 440 001	Graisse PTFE (boite de 450g)	PTFE grease box (450g / 0.99 lb)	Dose mit PTFE-Fett (450 g)	Caja de grasa PTFE (450 g)	1

- \* Pièces de maintenance préconisées.
- \* Preceding the index number denotes a suggested spare part.
- \* Bezeichnete Teile sind empfohlene Ersatzteile.
- \* Piezas de mantenimiento preventivas.