

DOCUMENTATION

**FLOWMAX® AIRMIX®
PROPORTIONING PUMP**

PU 2160 F

Manual : 582.175.110-UK - 2012

Date : 01/12/20

Supersede :

Modif.:

TRANSLATION FROM THE ORIGINAL MANUAL

IMPORTANT : Before assembly and start-up, please read and clearly understand all the documents relating to this equipment (professional use only).

THE PICTURES AND DRAWINGS ARE NON CONTRACTUAL. WE RESERVE THE RIGHT TO MAKE CHANGES WITHOUT PRIOR NOTICE..

SAMES KREMLIN SAS

13, chemin de Malacher
38 240 - MEYLAN - France
 : 33 (0)4 76 41 60 60

www.sames-kremlin.com



INSTALLATION AND SAFETY INSTRUCTIONS

TRANSLATION FROM THE ORIGINAL MANUAL

IMPORTANT : Before assembly and start-up, please read and clearly understand all the documents relating to this equipment (professional use only).

THE PICTURES AND DRAWINGS ARE NON CONTRACTUAL. WE RESERVE THE RIGHT TO MAKE CHANGES WITHOUT PRIOR NOTICE.

SAMES KREMLIN SAS
13, chemin de Malacher
38 240 - MEYLAN - France
☎ : 33 (0)4 76 41 60 60

www.sames-kremlin.com

1. SAFETY INSTRUCTIONS

GENERAL SAFETY INSTRUCTIONS



CAUTION : The equipment can be dangerous if you do not follow our instructions concerning installation and servicing described in this manual and in accordance with applicable European standards and local national safety regulations.

Please carefully read all the instruction literature before operating your equipment.

Only trained operators can use the equipment.

The foreman must ensure that the operator has understood the safety instructions for this equipment as well as the instructions in the manuals for the different parts and accessories.

Read carefully all instruction manuals, label markings before operating the equipment.

Incorrect use may result in injury. This equipment is for professional use only. It must be used only for what it has been designed for. Never modify the equipment. The parts and accessories supplied must be regularly inspected. Defective or worn parts must be replaced.

Guards (motor cover, coupling shields, connectors,...) have been designed for a safe use of the equipment.
The manufacturer will not be held responsible for bodily injury or failure and / or property damage due to destruction, the overshadowing or the partial or total removal of the guards.

Never exceed the equipment components' maximum working pressure.

Comply with regulations concerning safety, fire risks, electrical regulations in force in the country of final destination of the material. Use only products or solvent compatible with the parts in contact with the material (refer to data sheet of the material manufacturer).

PICTOGRAMS

A	B	C	D	E	F
NIP HAZARD	WARNING MOVING ELEVATOR	WARNING MOVING PARTS	WARNING MOVING SHOVEL	DO NOT EXCEED THIS PRESSURE	HIGH PRESSURE HAZARD
G	H	I	J	K	L
RELIEF OR DRAIN VALVE	WARNING HOSE UNDER PRESSURE	WEAR GLASSES OBLIGATORY	WEAR OF GLOVES IS OBLIGATORY	PRODUCT VAPOR HAZARDS	WARNING HOT PARTS OR AREAS
M	N	O	P	Q	R
ELECTRICAL HAZARD	WARNING FIRE HAZARDS	EXPLOSION HAZARDS	GROUNDING	WARNING (USER)	WARNING SERIOUS INJURIES

PRESSURE HAZARDS



Current legislation requires that an **air relief valve** be fitted in the air supply circuit to the air motor to prevent over pressurisation. This safety feature, ensures that it is not possible to supply the air motor with excessive air pressure that may cause injury.

Please ensure that a **material drain valve** is fitted in the fluid circuit to drain and depressurise the circuit. Once depressurised and drained, work /servicing may then commence on the equipment. Please remember to close these valves when restarting the system.

HIGH PRESSURE INJECTION HAZARDS



When working with high pressure equipment, special care is required. Fluid leaks can occur. There is a risk of material being injected to any exposed parts of body, this could cause severe injury :



- medical care must be sought immediately if paint is injected under the skin or in other parts of the body (eyes, fingers).
- never point the spray gun at any one. Never try to stop the spray with your hands or fingers nor with rags or similars.
- **follow the shut down procedure and always depressurize air and fluid circuits** before carrying out any servicing on the gun (cleaning, checking, maintenance of the material or cleaning of the gun nozzles).
- for the guns equipped with a safety device, always lock the trigger when not in use.

FIRE - EXPLOSION - SPARKS - STATIC ELECTRICITY HAZARDS



A poor earth connection, inadequate ventilation, sparks or static electricity can cause an explosion or fire. to avoid these risks when using or servicing SAMES KREMLIN equipment, the following safety procedures must be followed :



- ensure a good earth connection and ground the parts to be handled i.e. solvents, materials, components and equipment,
- ensure adequate ventilation,
- keep working area clean and free from waste solvents, chemicals, or solid waste i.e. rags, paper and empty chemicals drums,
- never use electrical switches / power if in an atmosphere of volatile solvent vapour,
- stop working immediately in case of electrical arcs,
- never store chemicals and solvents in the working area.
- use paint whose flash point is the highest possible to prevent from any formation of gas and inflammable vapours (refer to materials' safety instructions),
- install a cover on the drums to reduce the diffusion of gas and vapours in the spraybooth.

TOXIC PRODUCT HAZARDS



Toxic products or vapours can cause severe injury not only though contact with the body, but also if the products are ingested or inhaled. It is imperative :



- to know the material products and their risks,
- notified or hazardous materials must be stored in accordance with the regulations,
- the material must be stored in an appropriate container, never place materials in a container where there is a risk of spillage or leakage,
- a procedure must be applied for the safe disposal of waste material. It must comply with all prevailing regulations and legislations of the country where the equipment is to be used,
- protective clothing should always be worn in compliance with the material manufacturers' recommendations,
- depending on the application and chemical safety instructions, safety glasses, hearing protective earplug, gloves, foot wear, protective masks and possible breathing equipment should be worn to comply with the regulations (Refer to chapter "Safety equipment of SAMES KREMLIN selection guide).



CAUTION!

It is forbidden to use material containing high concentrations of halogenated hydrocarbon solvents with **aluminium** or **zinc fillers**. Non-compliance with the instructions may cause explosion risk causing serious or fatal injury.



EQUIPMENT REQUIREMENTS

Guards (motor cover, coupling shields, connectors,...) have been designed for a safe use of the equipment.

The manufacturer will not be held responsible for bodily injury or failure and / or property damage due to destruction, the overshadowing or the partial or total removal of the guards.

PUMP



Before carrying out any work, it is imperative to read and clearly understand the disassembly and reassembly instructions before servicing. The operator must understand the equipment and the safety instructions. These instructions are available in the equipment manuals.



The air motor is designed to be mounted with a pump. Never modify any components or couplings. When operating, please keep hands away from moving parts. Before starting up the equipment, please read the PRESSURE RELIEF instructions. Please ensure that any relief or drain valves fitted are in good working order.

HOSES

- Keep hoses out of circulation areas, moving parts or hot surfaces,
- Never expose product hoses to temperature higher than + 60°C / 140° F or lower than 0°C / 32° F,
- Never pull or use the hoses to move the equipment,
- Tighten all fittings as well as the hoses before operating the equipment,
- Check the hoses regularly; change them if they are damaged,
- Never exceed the maximum working pressure (MWP) indicated on the hose.

USED PRODUCTS

Considering the wide variety of products that are available and can be used in our equipment it is impossible to check and make recommendations for all chemical data, regarding the risks of possible chemical attack and their long term chemical reaction

SAMES KREMLIN can not be held liable for :

- compatibility of wetted parts,
- risks to staff and the surroundings,
- for worn or defective parts, for faulty equipment or units, or the quality of final product.

It is the responsibility of the user to know and prevent any possible risks such as toxic vapours, fires or explosions. He shall determine the risks of immediate reactions or pursuant to repeated exposures of the staff,

SAMES KREMLIN shall not be liable for physical injuries, direct or indirect material damages caused by the use of chemicals.

2. HANDLING



Check the weight and the dimensions of the equipment

(☞ refer to 'Technical features' section of the instruction manual

If weight and dimensions are too important, the unloading must be carried out by means of a forklift or any other appropriate means with a qualified personnel and in a clear horizontal area to prevent from risks of damage injury or an accident.

The centre of gravity is not in the centre of the machine : carry out by hand a stability-test after having lifted the whole at 10 cm / 3.937" maximum.

After the unloading, the handling of the whole (eg: elevator pump) is carried out by means of a pallet truck taking the bottom part of the frame.

Remark : Each pump motor is fitted with a ring. The ring is designed for the hoisting of one pump and can not be used for the handling of the complete assembly.

3. STORING

Storing before installation :

- Storing ambient temperature : 0 / +50 °C / 0 / +122°F
- Protect the whole against dust, water trickling, dampness and shocks.

Storing after installation :

- Operating temperature : +15 / +35 °C / +59 / +138.2° F
- Protect the whole against dust, water trickling, dampness and shocks.

4. INSTALLATION OF THE EQUIPMENT

The machine is installed on a stable horizontal floor (for eg a concrete flag).

The machine shall be made stable by the use of holding down bolts or by the use of other anchoring methods, strong enough to prevent unintended bodily movement of the equipment.



To avoid risks caused by static electricity, the equipment as well as its components must be grounded.

- **For the pumping equipments** (pumps, pneumatic rams, frame...), a section wire of 2.5 mm² is fixed on the material. Use this wire to connect the material to "the general ground". In case of severe environments (mechanical protection of the wire of earthing insufficient, vibrations, mobile material...) where function damages at the ground are probable, the user have to replace the provided wire of 2.5 mm² by a device more adapted to its environment (wire with a more important section, bonding strip, fixing by thimble with eyelet...).

The continuity of the ground must be controlled by a qualified electrician. If the continuity of the ground is not ensured, check the terminal, the wire and the earthing point. **Never** use the material without have solved this problem.

- In the severe cases of environments (mechanical protection of the wire of earthing insufficient, vibrations, mobile material...) where damages of the function put at the ground are probable, the user will have to replace the wire of 2.5 mm² provided, by a device more adapted to its environment (wire of more important section, bonding strip, fixing by thimble with eyelet...),
- **The gun** must be 'grounded' via a material hose or an air hose. In case of spraying by means of a gun with cup, the air hose must be conductive,
- **The materials to be painted** must also be grounded.

All the materials situated in the working area shall be grounded.



- **Never store** more than necessary inflammable materials inside the working area,
- The materials must be stored into **approved drums** and grounded,
- Use only grounded **metals containers** for the use of cleaning solvents,
- **Cardboard and paper are prohibited.**

5. MARKING OF THE EQUIPMENT

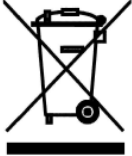

Each equipment has a label plate with the name of the manufacturer, the equipment part number, the interesting informations to use correctly the equipment (pressure, voltage,...) and sometimes the above pictogram.

The equipment is designed with and consists of high quality materials and components which can be re-used.

The 2012/19/UE European Directive covers all equipments with a crossed-out bin pictogram. Please inform yourself about the collection systems for electric and electronic equipments.

Please act in accordance with local rules and **do not dispose of old equipment with household wastes**. A correct disposal of old equipment will help prevent negative consequences for the environment and health.



INSTRUCTION MANUAL
FLOWMAX® AIRMIX® PROPORTIONING PUMP
MODEL PU 2160 F

Manual : 2011 573.182.112

Date : 30/11/20 - Supersede : 4/11/08

Modif. : Update

TRANSLATION FROM THE ORIGINAL MANUAL

IMPORTANT : Before assembly and start-up, please read and clearly understand all the documents relating to this equipment (professional use only).

THE PICTURES AND DRAWINGS ARE NON CONTRACTUAL. WE RESERVE THE RIGHT TO MAKE CHANGES WITHOUT PRIOR NOTICE.

SAMES KREMLIN SAS
13, chemin de Malacher
38 240 - MEYLAN - France
☎ : 33 (0)4 76 41 60 60

www.sames-kremlin.com

INSTRUCTION MANUAL
FLOWMAX® AIRMIX® PROPORTIONING PUMP
MODEL PU 2160 F

CONTENTS

1. SAFETY.....	2
2. TECHNICAL FEATURES.....	3
3. OPERATING PRINCIPLE	4
4. INSTALLATION	5
5. OPERATING	6
6. ADJUSTMENTS.....	9
7. CHANGING MIX RATIO	10
8. SHUTDOWN AT THE END OF WORK	10
9. DAILY CARE.....	10
10. TROUBLESHOOTINGS	11
11. DISASSEMBLY.....	12
12. ASSEMBLY INSTRUCTIONS.....	15

ADDITIONAL DOCUMENTATIONS :

	Spare parts
Two-component pump, model PU 2160 F	Doc. 573.331.050
Bare proportioning pump	Doc. 573.332.050
Motor	Doc. 573.272.050
Mixing / flushing manifold	Doc. 573.333.050

Dear Customer,

We thank you very much for purchasing our PU 2160 F Flowmax® Airmix® two-component pump. You are the owner of one of the most reliable pumping system available on the market.

Special care has been taken during all designing and manufacturing process to make sure your investment will provide full satisfaction.

To get the best result, safe and efficient operation of your equipment, we advice you to read and make yourself familiar with this instruction and service manual. Indeed, the non-compliance with this instructions and precautions stated in this manual could reduce the equipment working life, result in operating trouble and create unsafe conditions.

1. SAFETY

■ GENERAL SAFETY INSTRUCTIONS



CAUTION : The equipment can be dangerous if you do not follow our instructions concerning installation and servicing described in this manual and in accordance with applicable European standards and local national safety regulations.

Please carefully read all the instruction literature before operating your equipment.

Only trained operators can use the equipment.

The foreman must ensure that the operator has understood the safety instructions for this equipment as well as the instructions in the manuals for the different parts and accessories.

Read carefully all instruction manuals, label markings before operating the equipment.

Incorrect use may result in injury. This equipment is for professional use only. It must be used only for what it has been designed for. Never modify the equipment. The parts and accessories supplied must be regularly inspected. Defective or worn parts must be replaced.

Never exceed the equipment components' maximum working pressure.

Comply with regulations concerning safety, fire risks, electrical regulations in force in the country of final destination of the material. Use only products or solvent compatible with the parts in contact with the material (refer to data sheet of the material manufacturer).



**Refer to 'Installation and safety instructions' document
(doc. 578.001.130-UK)**

■ SPECIFIC SAFETY INSTRUCTIONS

- ↻ Use only non-static quality air hose to connect the pump to the spray gun,
- ↻ Ground the pump (use the connection on the pump),
- ↻ The compressed air supply must not exceed 6 bar / 87 psi.
- ↻ Make sure the lubricant in the cup of the fluid section is compatible,
- ↻ Use the appropriate solvent for the material being sprayed to increase the equipment working life.

2. TECHNICAL FEATURES

The PU 2160 F fixed ratio pump is used for applying two component material with one Airmix ® gun.

The proportioning pump is mounted on a cart and composed of :

- a mixer,
- a PRODUCT/SOLVENT selection assembly,
- a suction rod and a drain rod for BASE,
- a suction rod for the solvent,
- a gravity container and an hose for CATALYST.

Mix ratio 1/1, 2/1, 5/1, 10/1 (depending upon choice of CATA fluid section)

Viscosity..... 180 s CA4 maxi

Motor type 700-2

The BASE fluid section is an Intensive™ version. The CATALYST fluid section is a FLOWMAX® technology.

Mix ratio	Delivery per cycle (cm3)		Flow rate at 20 cycles (l / US gal)	Pressure ratio	Fluid pressure at 6 bar / 87 psi (bar / psi)	Fluid pressure at 4 bar / 58 psi (bar / psi)
	A	B				
1/1	19	19	0.8 / 0.21	10	60 / 870	40 / 580
2/1	19	9,5	0.6 / 0.16	15	90 / 1305	60 / 870
5/1	19	3,8	0.5 / 0.13	18	108 / 1566	72 / 1044
10/1	19	1,9	0.4 / 0.10	20	120 / 1740	80 / 1160

Air supply pressure	Minimum : 3 bar / 43.5 psi - Maximum : 6 bar / 87 psi
Air consumption of the proportioning pump (Nm3/h)	1,2 x (mixed fluid flow rate in l/mn) x pump ratio x (motor air pressure + 1 bar) x 60/1000
Wetted parts	<p>PU with 1/1, 2/1 & 5/1 ratio</p> <ul style="list-style-type: none"> • BASE and CATA fluid section :stainless steel • CATA circuit : stainless steel • Mixer : stainless steel, treated steel and polyethylene <p>PU with 10/1 ratio</p> <ul style="list-style-type: none"> • BASE fluid section : stainless steel • CATA fluid section : 316L stainless steel • CATA circuit : 316L stainless steel • Mixer : 316L stainless steel and polyethylene <p>Bellows : PTFE</p>
Fittings	Air inlet : F 3/8 BSP Spraying air : M 1/4 NPS Fluid outlet (manifold) : M 1/2 JIC
Overall weight	60 kg / 132 lb
Dimensions	110 x 55 x 50 cm
Maximum operating temperature	50° C / 122° F
Noise level (to 1m)	80 dB A (depending upon ISO 3746 standard)

3. OPERATING PRINCIPLE

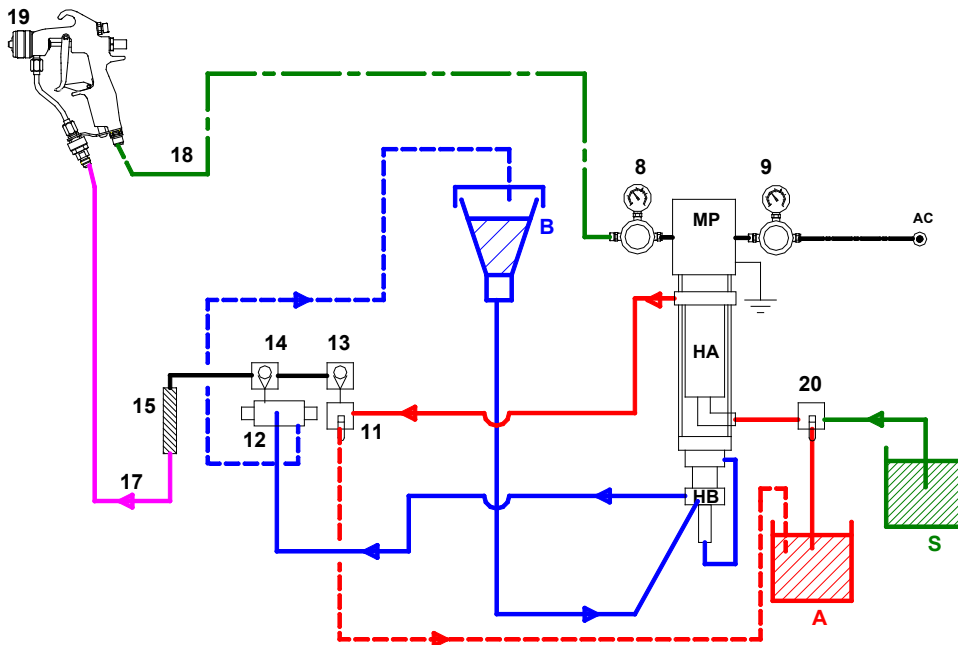

This pump measures and mixes 2 components A and B to a single defined volume proportion (see data sheet of the product).

The fluid sections HA and HB are coupled to an air motor MP. Their sizes have been calculated in order that each delivers the components A and B to the predetermined proportion.

- ♦ Fluid section HA draws and delivers the BASE A.
- ♦ Fluid section HB draws and delivers the CATALYST B.

When pulling gun trigger (19), proportioning pump starts cycling and draws the BASE and the CATALYST. Simultaneously, they are delivered in valves (11 and 12), check valves (13 and 14) and are mixed in the static mixer (15). Then, they flow out completely mixed before passing through hose (17) to the gun.

As soon as the trigger is released, the proportioning pump stops cycling :

- ♦ The regulator (9) regulates the air pressure to the pump, thus regulating material pressure.
- ♦ The regulator (8) regulates the atomizing air pressure to the gun.

Nota :

The valve (11) is a three-ways' valve :

- handle horizontally \Rightarrow fluid circulation (priming stage),
- handle vertically \Rightarrow fluid towards mixer (working stage, flushing stage).

The valve (12) is a color changer fitted with 2 fluid valves. These valves are piloted pneumatically alternately, connecting the air tube in spiral on one or the other valve :

Left connection \Rightarrow fluid circulation (priming stage)



Right connection \Rightarrow fluid towards mixer (working stage).



Nota : During the FLUSHING stage,

- the BASE fluid section draws solvent; that solvent is exhausted towards the manifold, the mixer and the gun.

\hookrightarrow the BASE circuit and the mixed circuit will be flushed.



- the catalyst circulates. The CATALYST circuit is not flushed.

4. INSTALLATION

The pumps are designed to be installed in a spray booth.

DESCRIPTION OF THE LABEL MARKING

Marking in accordance with the ATEX regulation

	TYPE	<input type="text"/>
	RATIO	<input type="text"/>
○	SERIE-SERIAL	<input type="text"/> ○
	P air	<input type="text" value="6 bars - 87 psi"/>
	P prod	<input type="text" value="bar - psi"/>

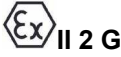
SAMES KREMLIN 93240 STAINS FRANCE	Name and address of the manufacturer
	II : group II 2 : class 2 Surface equipment meant to an area where explosive atmospheres due to gas, vapours, mists are liable to appear from time to time in usual operating. G : gas
TYPE	Pump version: PU 2160 F
RATIO	Mixing ratio
SERIE - SERIAL	Number given by SAMES KREMLIN
P air : 6 bar / 87 psi	Air supply maximum pressure of the pump motor
P prod : xx bar / xx psi	Maximum fluid pressure at the pump outlet

INSTALLATION DIAGRAM

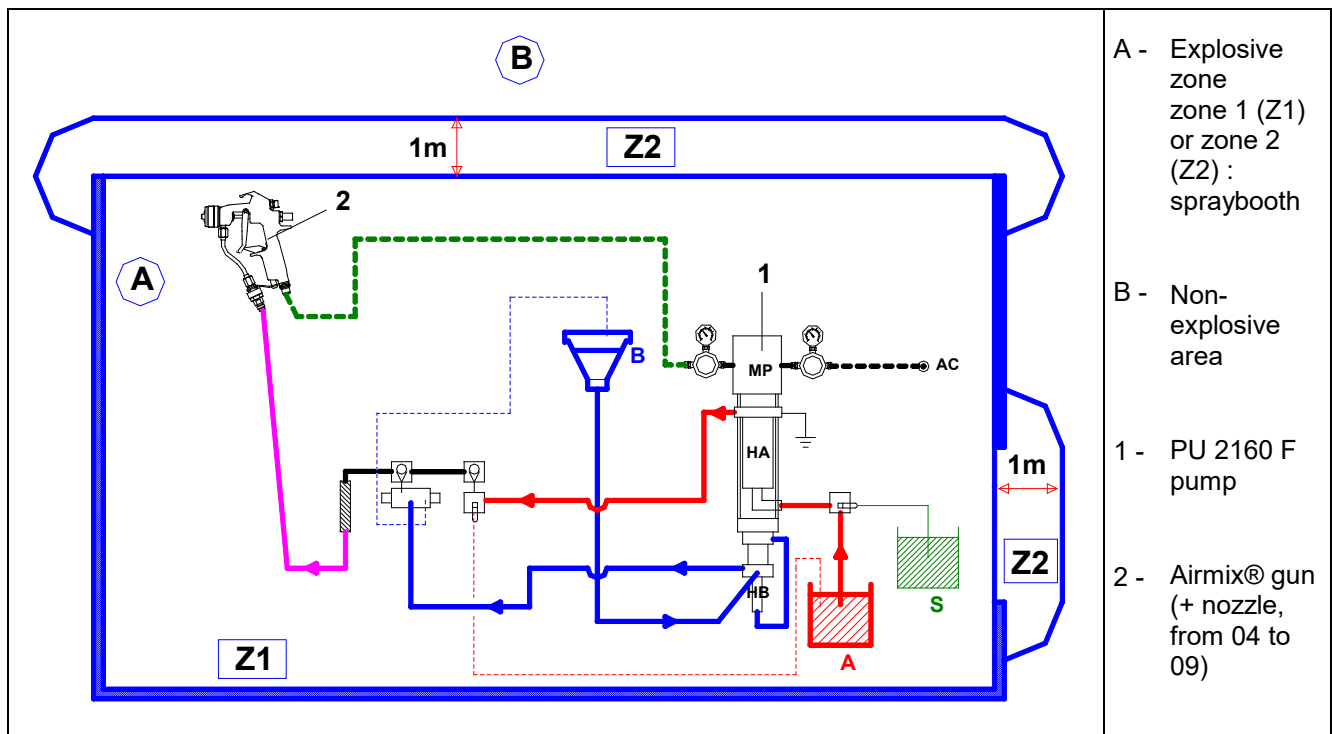

■ INSTALLATION

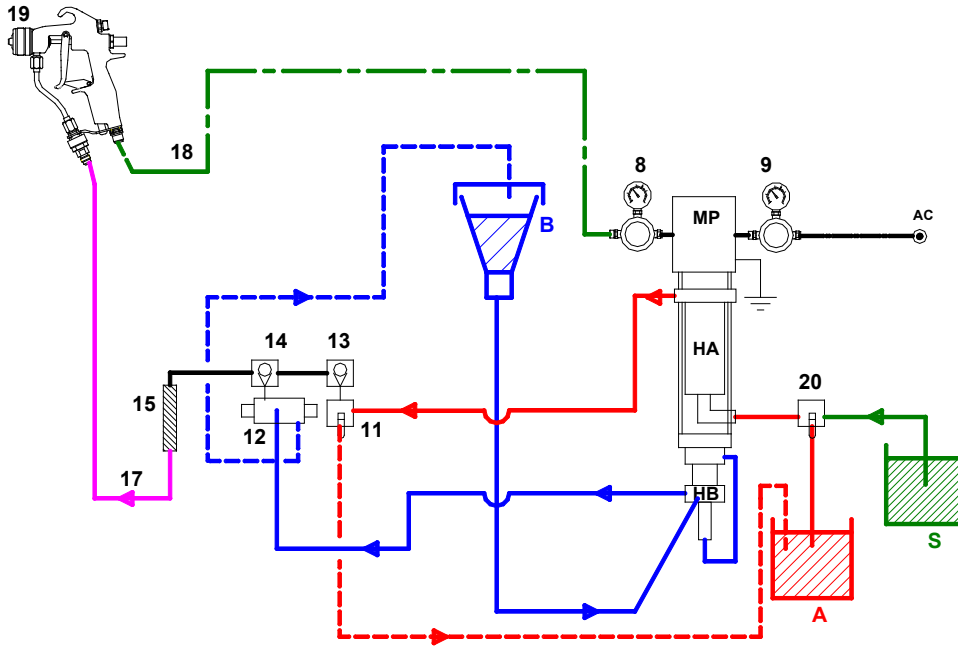

Interconnect hoses (18) and (17) between the pump and the AIRMIX ® gun :

- ♦ The hose (18) should be static proof (green band). I.D. 7 mm / 9/32".
- ♦ The hose (17) should be an AIRMIX ® one. I.D. 4,8 mm / 3/16" or 6,5 mm / 1/4".

Connect the pump air supply to the compressed air system with an hose - I.D. 10 mm / 3/8".

Nota : these hoses are not included in the equipment.

Choose an AIRMIX ® nozzle (size from 04 to 09 - refer to chart of nozzles in the gun instruction manual) and install it on the gun (19).



The PU 2160F pump is fitted with an earth cable. Ground the pump.

Fill with 'T' lubricant or with the appropriate lubricant the BASE fluid section flange. Fill the cup to the 3/4.

Unscrew the 2 air regulators (8 & 9), then supply the equipment with air (maximum P = 6 bar / 87 psi, clean air).



→ **Do not install isolating valve on the CATA supply system** (between the tank and the FLOWMAX ® fluid section). **It will damage the bellows.**

→ Do not install a system that will act as a non return valve.

→ You **must not** create an **overpressure** in the CATA system.

5. OPERATING

■ LABEL

The label stucked on the pump explains the 3 operating stages of the pump : PRIMING - WORKING - FLUSHING.

The 3 operating stages are selected :

- working the manifold valve (11) (→ index A on the label),
- operating one of the valves of the color changer (12) (→ index B on the label),
- working the valve (20) located at the base and solvent suction (→ index S on the label).

Stages :	
1 - Priming	
2 - Working	
3 - Partial flushing	

The label indicates also the air pressure adjustment on the motor of the pump.

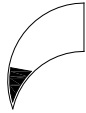

: Low pressure



: Higher pressure

■ FIRST START UP



CAUTION : This pump has been checked and tested with water in our factory.

During the first start up, a flushing of the circuits with solvent is required to ensure a good operating of this pump.

Be certain the gun trigger is released and hoses are properly interconnected.

Insert BASE drain rod and CATA hose into waste containers.

Insert suction rod of BASE fluid section into SOLVENT container.

Fill up with SOLVENT the CATALYST container.

Be certain the manifold hand levers are in the PRIMING position.

Adjust the black regulator 'Air motor' (9) between 0.5 and 2 bar / 7 and 29 psi.

Both components must flow freely from BASE drain rod and CATA hose into waste containers.

Once drained the circuits, insert the drain rod into the solvent container and the CATALYST hose into the other container. Make the materials circulate until air bubbles are evacuated.

Unscrew the air regulator (9), then empty the solvent of the CATA container.

Prepare the materials :

- ♦ Fill up a container with Material A (BASE),
- ♦ Fill up the pump container (Maximum 10 liters / 2.6 US gal) with material B (CATALYST),
- ♦ Fill up a container with Flushing Solvent S.

Insert BASE suction rod (Ø 16) into BASE container and the 'BASE' rod into a waste container.

Insert SOLVENT rod into solvent container.

Insert 'CATA' hose into a waste container.

PRIME (Stage 1) to evacuate solvent into fluid sections, then insert BASE drain rod into BASE container and CATA hose into CATA container.

■ MATERIAL PRIMING (STAGE 1)

Move the valve (20) hand lever to supply the pump with material A (BASE).

Move the valve (11) hand lever horizontally.

Connect the air tube on the hole on the far left of the plate (⇒ opening of the CTM valve to the container B).



Screw the black regulator until pump begins to start up (pressure : from 1 to 2 bar / from 14.5 to 29 psi).

The base A is drawn then delivered by the BASE fluid section. It passes through the valve (11) of the manifold and goes back to the container A.

The catalyst flows from container B, is drawn by the CATA fluid section. It passes through the valve (12) of the manifold and goes back to the container B.

Leave the materials circulate for a few minutes. When air bubbles are evacuated, the priming is over.

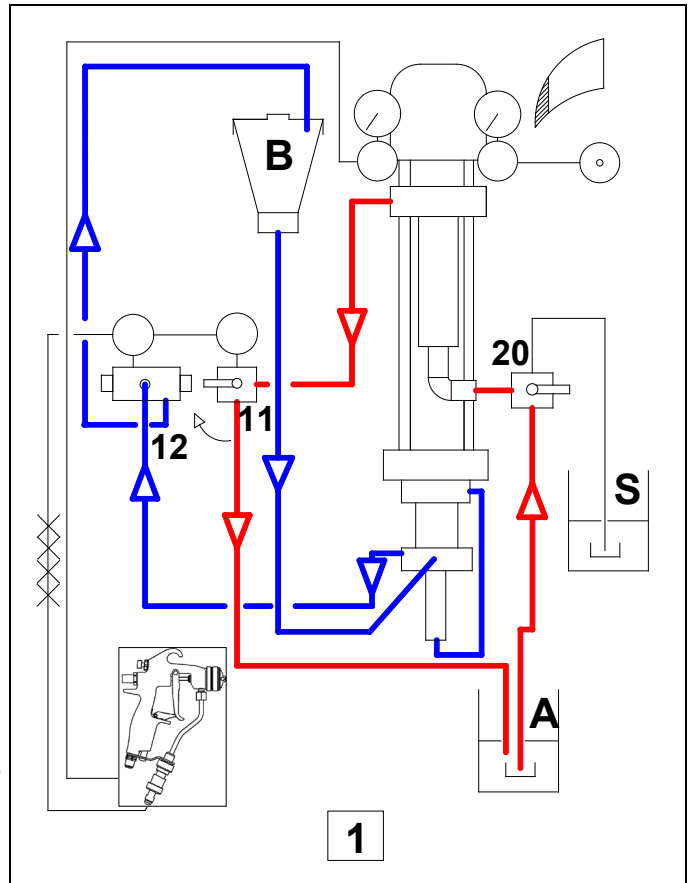

■ WORKING (STAGE 2)

Leave the valve (20) hand lever in the same position (the pump must be supplied with materials A and B).

Position the valve (11) hand lever vertically.

Connect the air tube on the hole on the far right of the plate (⇒ opening of the CTM valve towards the AR valve).



Screw the black regulator 'Pump pressure' until the pump begins to start up.

The base A and the cata B are drawn then delivered by their respective fluid section. Each material comes to the manifold and is mixed at the outlet in the mixer.

Point and trigger the gun into a waste receptacle.

When material flows out regularly, screw the phosphorous regulator "Spraying air".

Adjust the 2 regulators to get a correct fan :

- adjust the material pressure with the black regulator,
- adjust the spraying air with the phosphorous regulator.

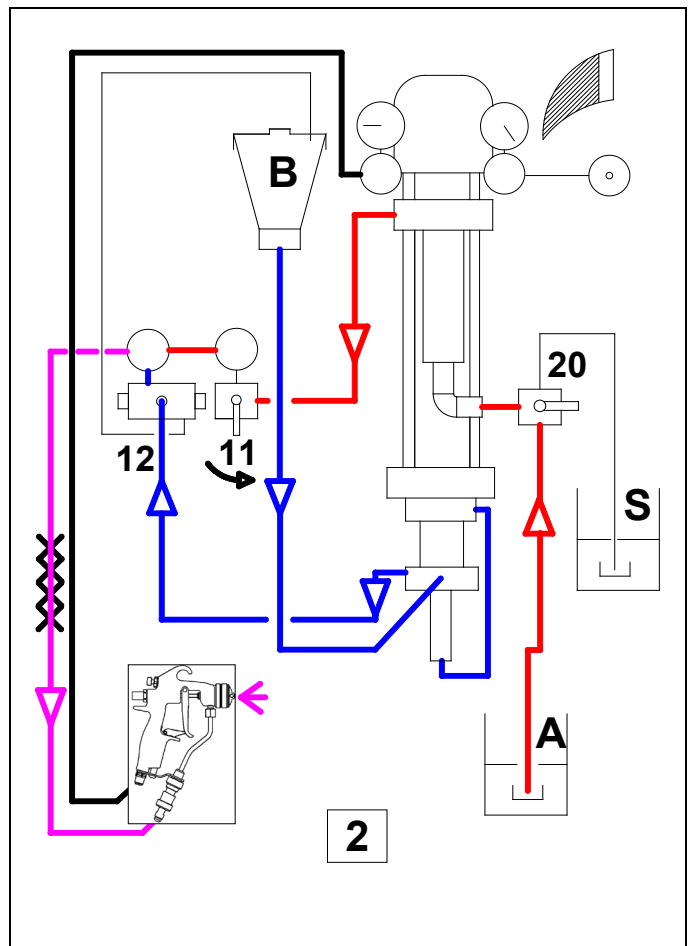

■ PARTIAL FLUSHING (STAGE 3)

If the working shutdown lasts longer than the material "working life", carry out a PARTIAL flushing.

The FLUSHING stage enables to flush the BASE circuit and the mixed material.

Move the valve (20) hand lever to supply the BASE fluid section with solvent.

Position the valve (11) hand lever vertically.

Connect the air tube on the hole on the far left of the plate (opening of the CTM valve towards the container B ⇒ circulation of the catalyst).



Screw the black regulator 'Pump Pressure' until pump begins to start (pressure : from 1 to 2 bar / from 14.5 to 29 psi).

The solvent S and the cata B are drawn and delivered via their respective fluid section. Each material comes to the manifold valves : the CATA is sent to the container, the solvent passes through the manifold, the mixer and comes to the gun.

Remove aircap and tip from the gun and clean them carefully.

Point and trigger the gun into a waster receptacle.

When clean solvent flows out, the circuit is flushed.

Leave the equipment until a next utilization

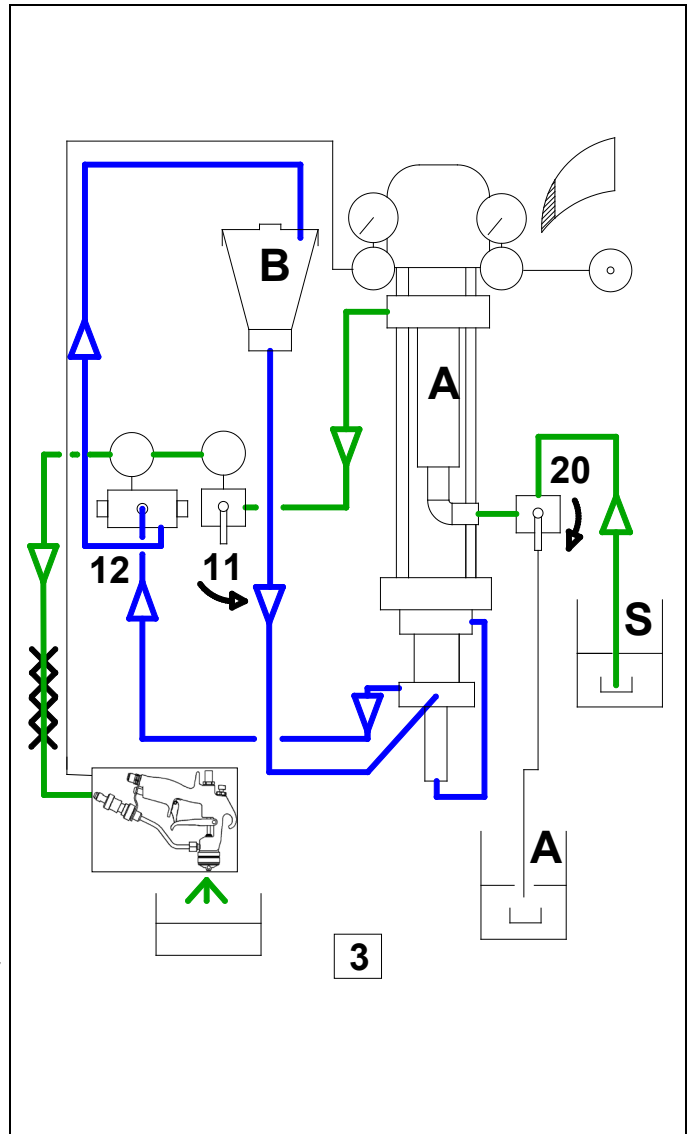

6. ADJUSTMENTS

TROUBLE	CAUSE	SOLUTION
Coating not thick enough	Not enough material	Increase the material fluid pressure using black knob.
		Spray slower or closer to part being painted.
Sags, runs	Too much material	Decrease the material pressure using black knob.
	Distorted spray fan	Refer to gun instruction manual

7. CHANGING MIX RATIO

The PU 2160 features a fixed ratio proportioning system (ratio : 1/1, 2/1, 10/1 according to the choice of the CATA fluid section).

To change the ratio, the CATALYST fluid section must be changed with a fluid section of a different ratio (refer to PU 2160F spare parts' list).

8. SHUTDOWN AT THE END OF WORK

■ COMPLETE FLUSHING : ONLY FOR MATERIAL / COLOR CHANGE OR LONG DURATION SHUTDOWN.

Carry out a partial flushing (refer to § 7).

Empty the CATALYST container - replace CATALYST with CLEAN solvent.

Insert SOLVENT suction rod into a container of CLEAN solvent.

Place the valve (11) hand lever vertically.

Connect the air tube in spiral on the far right of the plate (⇒ opening of the CTM valve towards the AR valve).

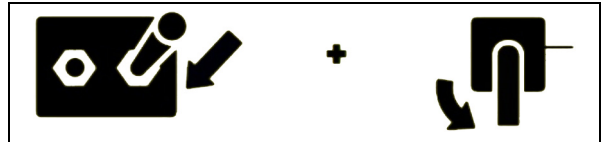

Adjust the black regulator (9) to 2 or 3 bar / 29 or 43.5 psi.

Point the gun into a waste container and make the fluid flow out until you get solvent.

Remove the aircap and the nozzle and clean them.

Remove and clean the mixer (15).

Remove and clean the CATA tank screen after having emptied the tank content.

➤ To get a perfect flushing, repeat that procedure twice using some CLEAN solvent.

Reinstall the aircap and the nozzle onto the gun.

Shut off the main air supply.

Leave the pump filled with clean solvent.

9. DAILY CARE

■ SPRAY GUN

Comply with the usual instructions of spray gun servicing (refer to spray gun instruction manual).

■ PUMP

Make sure the wetting cup of the BASE fluid section is filled up with T lubricant. Fill if necessary (level : 3/4 of the cup).

Regularly change the lubricant (this lubricant will normally be coloured by the paint). Make sure the wetting cup is clean and regularly clean it with solvent after having drained the lubricant.

Make sure the suction strainers and rods are clean and in good condition.

Check the hoses.

Flush the pump as often as necessary.

Never inject oil into the compressed air supply.

The CATALYST tank is fitted with a screen. Clean that screen regularly or change it, if necessary (filtration size : 50 MESH)

When stopping the pump, always leave it filled up with material.

For a short duration, if the flushing has not been carried out, leave the pump filled up with material.

For a long duration, after flushing the pump, leave it filled up with solvent.

Before cleaning or removing a component of the equipment, you must :

- 1 - stop the pump compressed air supply,
- 2 - place the manifold valves in 'circulation' position,
- 3 - trigger the gun to depressurize the hoses.

10.TROUBLESHOOTINGS

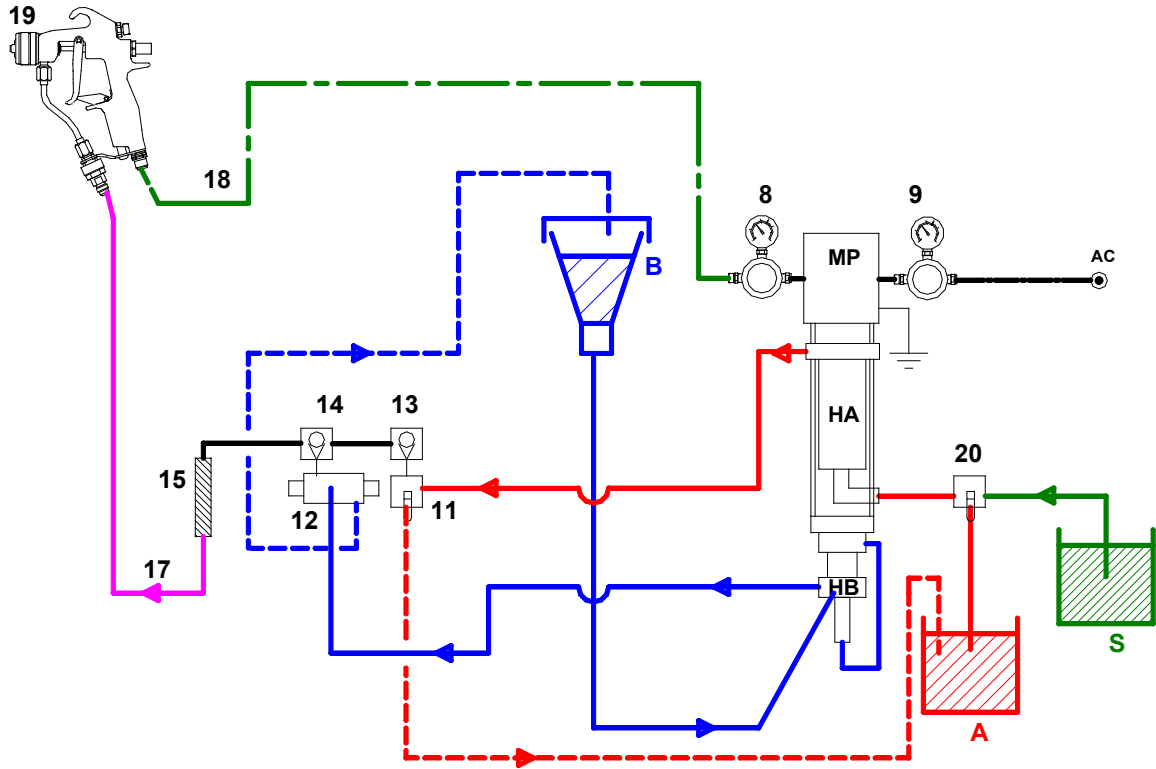

■ THE PUMP DOES NOT OPERATE

Check :

- ◆ It is supplied with air,
- ◆ The valves (11 & 12) are in 'WORK' position,
- ◆ The gauge (9) indicates a pressure between 2 and 6 bar / 29 to 87 psi,
- ◆ The mixer (15) and the hose (17) are not clogged,
- ◆ The mixer (15) and the hose (17) are not clogged,
- ◆ The gun filter, if there is one, is not clogged,
- ◆ The gun nozzle is not clogged.

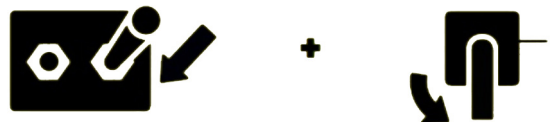

■ RATIO CHECKING

From time to time, you must check the ratio :

- 1 - The CATALYST container is translucent. Mark on the CATALYST level, then add a CATALYST volume (for example 1 liter / 0.26 US gal),
- 2 - Determine the volume of the BASE,
- 3 - Operate the pump until the volume of catalyst falls to its initial level,
- 4 - Determine the volume of BASE used. In this case, the ratio is :

$$\frac{\text{Volume of BASE used (in liters)}}{1 \text{ liter}} = \text{Material mix ratio} *$$

** Nota : The reading of the proportioning ratio is highly sensitive to the viscosity of the materials.*

11.DISASSEMBLY



WARNING !

Before any intervention on the pump :

- shut off the compressed air supply,
- place the manifold valves in 'circulation' position,
- trigger the gun to depressurize the circuits,
- empty the CATALYST container.

BASE FLUID SECTION - HA (Refer to Doc. 573.332.050)

To disassemble the **BASE** fluid section (HA), remove the lower part of the pump [the **CATALYST** fluid section (HB) and the suction kit (11)] removing the nuts (6), the tie-rods (4) and the fixing plate (9).

■ SUCTION VALVE

Unscrew the suction valve body (19).

The ball (22) is secured on the seat (20) by means of a stop ring (23).

Reinstall the suction valve assembly and change the seal (21).

■ EXHAUST VALVE

Unscrew the cylinder (17).

Unscrew the seat (26) by holding valve support (29) to remove ball (27).

Check if cup seal is not damaged (28), change it if necessary.

Reinstall the parts in the reverse order and tighten the seat (26) completely on the valve support (29). Change cylinder seal (18).

■ CARTRIDGE

To separate BASE fluid section from air motor, remove tie-rods (1), pin (3) and connecting pin (2).

Remove circlips (13) located in the fluid section flange (32) and pull cartridge (14) downwards to remove it.

Install a new cartridge (12).

Reinstall in the reverse order. Be careful not to damage the seal when inserting piston-rod (30) into cartridge (14).

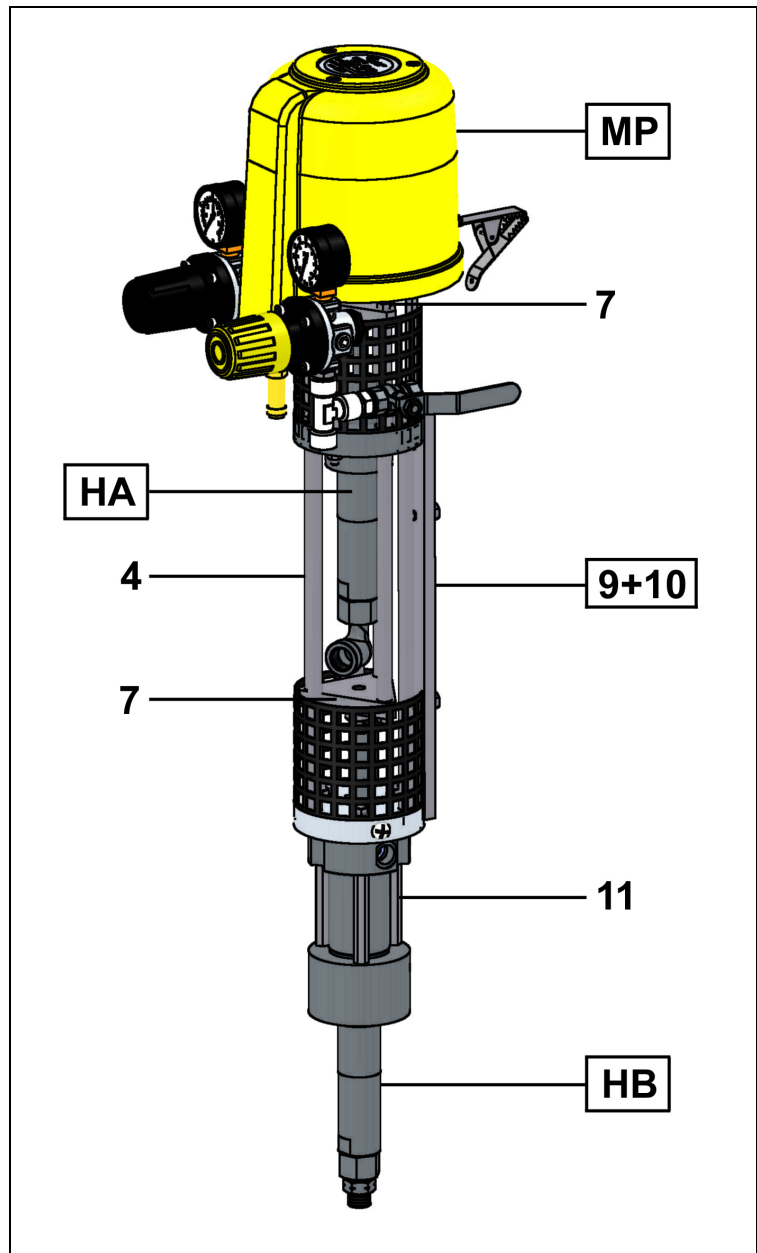

CATALYST FLUID SECTION - HB (Refer to Doc. 573.332.050)

- Ratio 1/1 & 2/1

- **SUCTION VALVE** (Refer to BASE fluid section - suction valve)
- **EXHAUST VALVE** (Refer to BASE fluid section - exhaust valve)
- **CARTRIDGE**

Pull on the cartridge (48) by means of a hook to remove it from the flange (44) of the suction kit.

Install a new assembly. Lubricate the seal (50).

Slide the cartridge (48) on the piston rod (46) and insert it in its housing until the stop.

Be careful not to damage the inner seal when inserting piston-rod into cartridge.

CATALYST FLUID SECTION - HB (Refer to Doc. 573.332.050) - Ratio 5/1 & 10/1

■ **SUCTION VALVE**

Unscrew suction valve body (58).

The ball (61) is secured on the seat (59) by means of a circlips (62).

Reinstall suction valve assembly and change the seal (60).

■ **NON-RETURN VALVE**

Unscrew the valve (71) by holding support (68) to remove ball (69).

Check if valve seal (70) is not damaged. Change it if necessary.

Reinstall in the reverse order. Be certain valve (71) is fully screwed on the valve support (68).

■ **CARTRIDGE**

Pull on the cartridge (52) by means of a hook to remove it from the flange (44) of the suction kit.

Install a new assembly. Lubricate the seal (54).

Slide the cartridge (52) on the piston rod (65) and insert it in its housing until the stop.

Be careful not to damage the inner seal when inserting piston rod into cartridge.

SUCTION KIT (Refer to Doc. 573.332.050) (Ind. 11)

■ **BELLOWS**

Disassembly :

Disassemble the whole (HB & 11) from the rest of the pump unscrewing the nuts (6) of the tie-rods (4) and removing the axis (2) and the pin (3) at flange level (7).

Remove the cylinder and the exhaust valve from the CATA fluid section.

On the suction kit (11) :

Take off the nuts (45) and the flange (39).

Pull the suction bearing upwards. The bellows (35), the skirt (36), the coupling rod (37) and the CATA piston rod (46 or 65 depending on the version) are drawn in by the suction bearing.

Take off the ring (41) located on the flange (39).

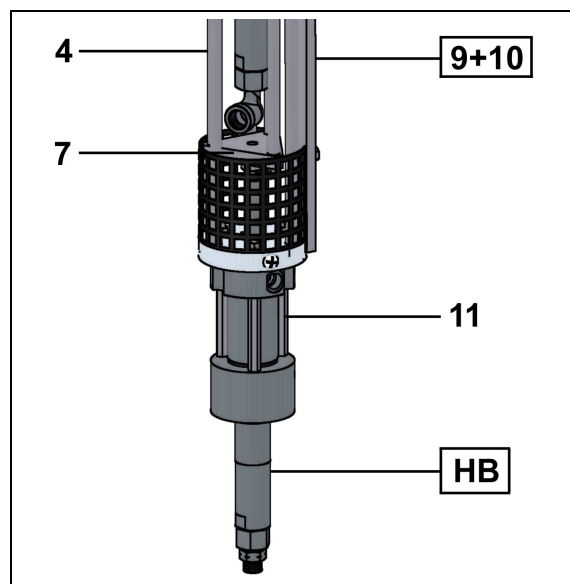

Remove the cylinder (43).

Disassemble the CATA piston rod (46 or 65) from the coupling rod (37).

Push on the cartridge of the CATA fluid section (48 or 52, depending on the version) to take it off the flange (44).

Assembly :

Grease the seals and the ring (40 & 41) before any installation.

Install new seals (40) into fluid flange (44) and into the suction bearing (38).

Install the ring (41) into the flange (39). Make it strain to insert it in its housing.

Install the cylinder (43) into the flange (44) until to stop (overcome the stiffness of the seal (40) without damaging it).

Slide the coupling rod (37) into the bellows (35) fitted with the skirt (36).

Associate the coupling rod (37) and the CATA piston rod (46 or 65) after the application of glue (low strength - Aneorobic adhesive - Loctite 222). Screw the 2 rods together (insert a metal rod on the holes located at each end and tighten).

Locate the bellows and the rods in the suction bearing (38).

Locate the whole on the tie-rods (42) as well as the flange (39).

Install the nuts (45).

 **Tighten them manually to get a play between the parts.**

Mount the coupling rod (37) on the upper part of the pump by means of the axis (2) and the pin (3) - consult drawing of the previous page.

 **If necessary, orientate the coupling rod (37) with care** in order not to damage the bellows (37). It is possible when the nuts (45) are not too tightened.

When the parts are installed, tighten the nuts (45) with a wrench # 10.

Install a new cartridge (48 or 52) before mounting the CATA fluid section.

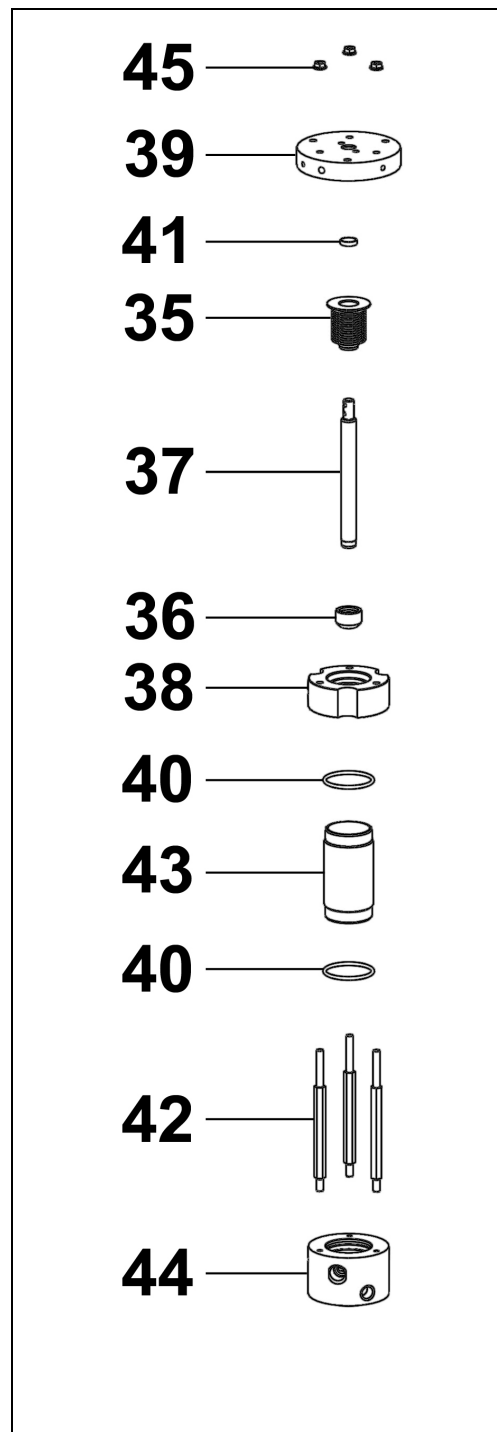

MOTOR (Refer to Doc. 573.272.050)

■ **MOTOR VALVE**

Disassemble hood (23) by removing the 3 screws (24).

Remove cover (19) by unscrewing the 4 screws (21).

Unscrew motor valve (15) by holding driving-rod (9).

Install the new motor valve (15) and block it on the driving-rod (9) thanks to the two flat parts located at its end.

Reinstall cover (19) with its 4 screws (21).

Reinstall hood (23) with its 3 screws (24).

Before reassembling the different components :

- Clean the parts with the appropriate cleaning solvent.
- Install new seals if it is necessary after having lubricated them with PTFE grease.
- Install new parts if necessary

12.ASSEMBLY INSTRUCTIONS

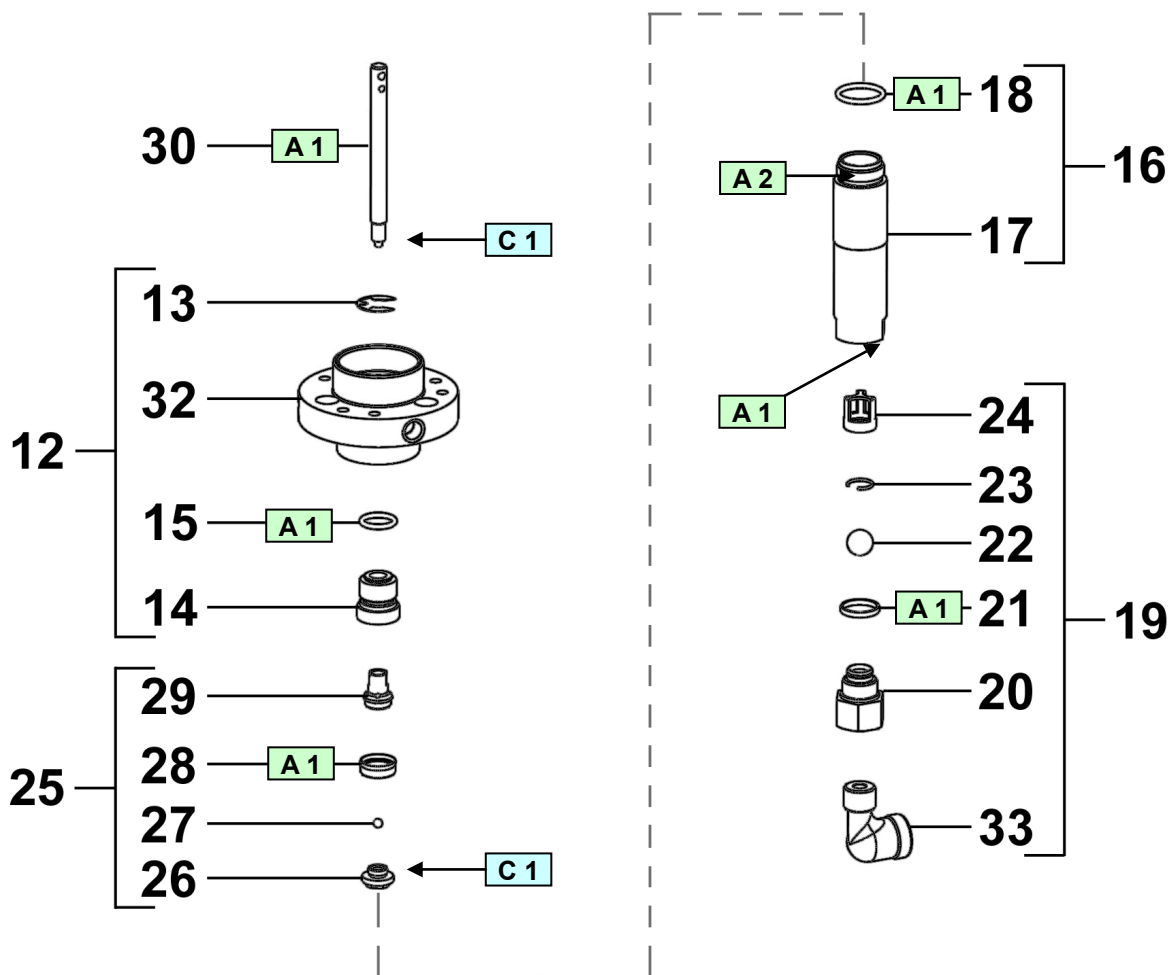

The above drawing represents the BASE fluid section. Transfer the same indications to the CATA fluid sections.

Index	Instruction	Description	Part number
A 1	PTFE grease	'TECHNILUB' grease (10 ml / 0.0026 US gal)	560.440.101
A 2	Anti-seize grease	Grease box (450 g / 0.99 lb)	560.420.005
C 1	Medium strength Aneorobic Pipe sealant	Loctite 5772 (50 ml / 0.013 US gal)	554.180.015

<p>Doc. 573.331.050 Date/Datum/Fecha : 26/11/20 Annule/Cancel/ Ersetzt/Anula : 04/11/08</p>	<p>Modif. / Änderung : Ind. / Pos. 10 : (# 151 586 850 → 151 586 870) Ind. / Pos. 15 : (# 051 586 540 → 051 531 800) Ind. / Pos. 23 : (# 051 586 511 → 050 452 010) + Ind. / Pos. 25 : (# 051 586 511 → 050 361 151) + Dessin / Drawing / Zeichung / Dibujo (pages / Seiten / páginas 1 & 3)</p>	<p>Pièces de rechange Spare parts list Ersatzteilliste Piezas de repuesto</p>
---	--	--

PU 2160 F

POMPE BI-COMPOSANT AIRMIX® FLOWMAX® / FLOWMAX® AIRMIX® TWO-COMPONENT PUMP
FLOWMAX® AIRMIX® ZWEI-KOMPONENTEN-PUMPE / BOMBA DOS COMPONENTES AIRMIX® FLOWMAX®

R = 1/1	R = 2/1	R = 5/1	R = 10/1
# 151.586.690	# 151.586.695	# 151.586.710	# 151.586.700

(R : Rapport de dosage / Mix ratio kit / Mischungsverhältnis / Relación dosificación)

PU 2160F

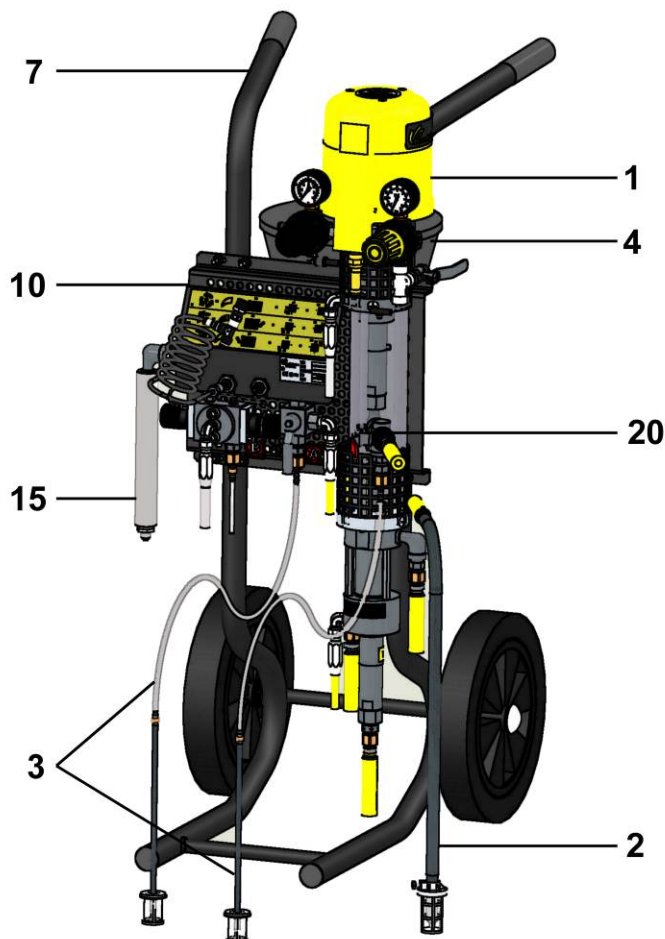

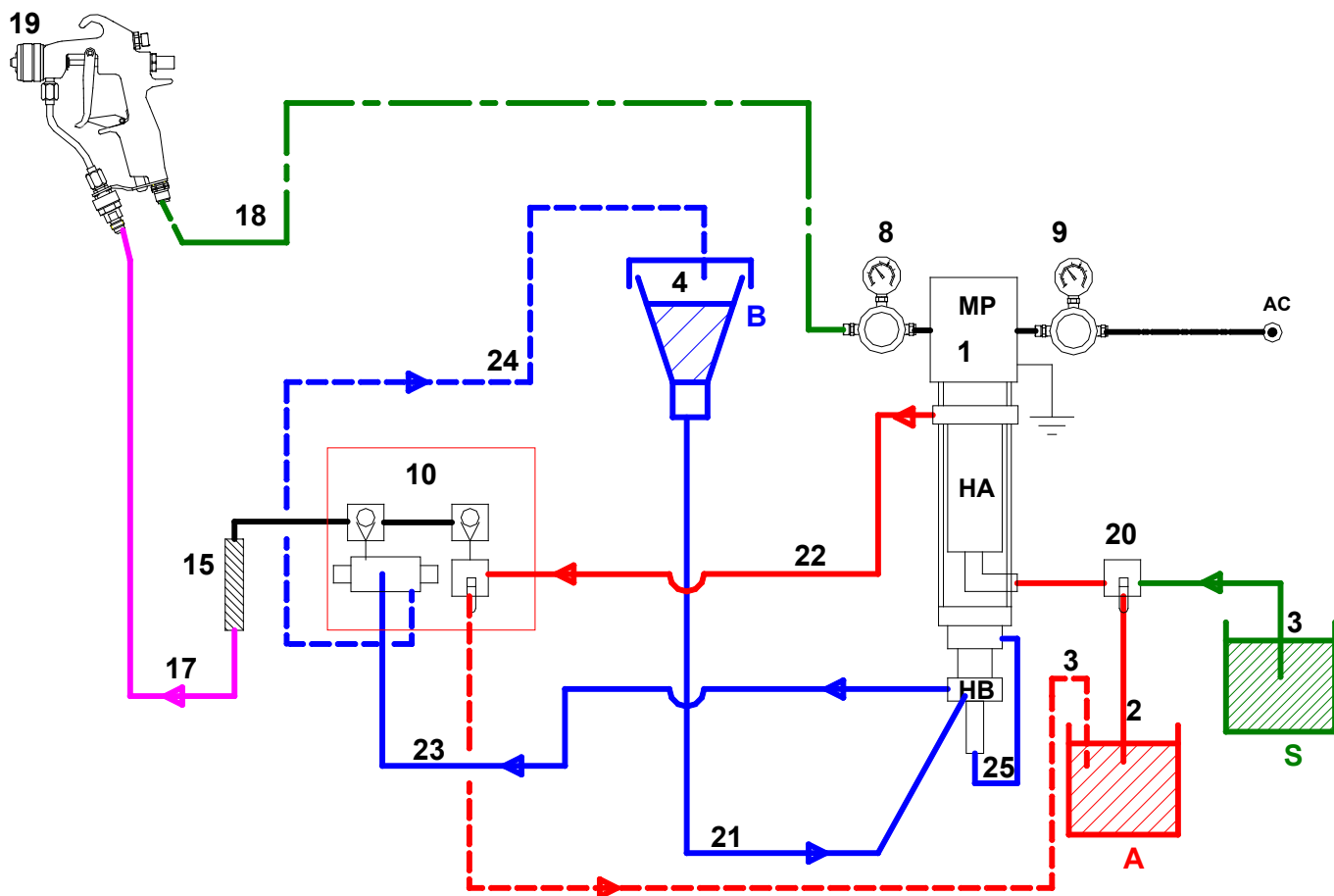

Ind	#	Désignation	Description	Bezeichnung	Denominación	Qté
1	--	Pompe de dosage (voir Doc. 573.332.050)	Proportioning pump (Refer to Doc. 573.332.050)	2-Komponenten-Pumpe (siehe Dok. 573.332.050)	Bomba dosificadora (consultar Doc. 573.332.050)	1
2	049 596 010	Canne d'aspiration Ø 16 (base)	Suction rod, Ø 16 / 5/8" (base)	Ansaugschlauch mit Rohr Ø 16 (Basis)	Caña de aspiración Ø 16 (base)	1
-	049 596 000	▪ Canne	▪ Rod	▪ Umlaufschlauch	▪ Caña	1
*-	051 531 600	▪ Crépine Ø 17	▪ Strainer assembly Ø17	▪ Ansaugsieb Ø 17	▪ Piña Ø 17	1
*-	151 539 903	▪ ▪ Kit de 4 éléments filtrants	▪ ▪ Strainer basket only (pack of 4)	▪ ▪ Siebkörbe (Satz à 4 St.)	▪ ▪ Kit de 4 elementos filtrantes (bolsa de 4)	1
3	051 665 620	Canne d'aspiration solvant et canne de recirculation base (Ø 10)	Solvent suction rod and base recirculating rod, Ø 10 / 3/8"	Ansaugschlauch für Ver- dünnung und Zirkulations- schlauch für Basis Ø10	Caña de aspiración disolvente y caña de recirculación base (Ø 10)	2
*-	138 010 800	▪ Kit de 4 éléments filtrants	▪ Strainer basket only (pack of 4)	▪ Siebkörbe (Satz à 4 St.)	▪ Kit de 4 elementos filtrantes (bolsa de 4)	1
4	151 586 630	Réservoir catalyseur	Catalyst container	Härterbehälter, kpl.	Bidón catalizador	1
*5	051 890 301	▪ Godet (6l)	▪ Cup (6l)	▪ Behälter (6l)	▪ Bidón (6l)	1
*6	151 890 399	▪ ▪ Tamis de rechange 50 MESH (les 2)	▪ ▪ Screen, 50 MESH (pack of 2)	▪ ▪ Ersatzsieb, 50 MESH (2 St.)	▪ ▪ Tamiz de recambio 50 MESH (bolsa de 2)	1

Ind	#	Désignation	Description	Bezeichnung	Denominación	Qté
7	051 221 000	Chariot 2 bras	Cart (2 arms)	Fahrgestell (2 Rohr)	Carretilla 2 brazos	1
10	151 586 870	Manifold (inox) (voir Doc. 573.333.050)	Manifold (stainless steel) (Refer to Doc. 573.333.050)	Mischerblock (Edelstahl) (siehe Dok. 573.333.050)	Manifold (inox) (consultar Doc. 573.333.050)	1
15	051 531 800	Mélangeur	Mixer	Mischer	Mezclador	1
*20	051 586 611	Robinet 3 voies F 3/8" BSP, inox	Three way valve, F 3/8", stainless steel	Hahn - 3 Wege 3/8" IG, Edelstahl	Grifo 3 vías H 3/8" G BSP, inox	1
21	051 586 612	Tuyau (PE) Ø 3/8", lg. 0,75 m	Hose (PE) Ø 3/8" - length 0,75 m	Materialschlauch Ø 3/8", (PE) Länge : 0,75 m	Tubería (PE) Ø 3/8", 0,75 m de largo	1
*22	050 450 106	Tuyau produit HP Ø 1/4" lg. 0,6 m (Base)	HP material hose Ø 1/4" - length 0,6 m (Base)	Materialschlauch Airmix® Ø 1/4, Länge : 0,6 m (Basis)	Tubería producto AP Ø 1/4", 0,6 m de largo (Base)	1
*23	050 452 010	Tuyau produit HP Ø 3/16" lg. 0,6 m (PTFE) (CATA)	HP material hose Ø 3/16" - length 0,6 m (PTFE) (CATA)	Materialschlauch Ø 3/16, Länge : 0,6 m (PTFE) (Härter)	Tubería producto AP Ø 3/16", 0,6 m de largo (PTFE) (catalizador)	1
*24	051 586 512	Tuyau (PE) Ø 1/4", lg. 1,5 m	Hose (PE) Ø 1/4" - length 1,5 m	Materialschlauch Ø 1/4" (PE) Länge : 1,5 m	Tubería (PE) Ø 1/4", 1,5 m de largo	1
*25	050 361 151	Tuyau (PE) Ø 3/8", lg. 0,6 m	Hose (PE) Ø 3/8" - length 0,6 m	Materialschlauch Ø 3/8", (PE) Länge : 0,6 m	Tubería (PE) Ø 3/8", 0,6 m de largo	1
-	149 990 020	Flacon de lubrifiant T (125 ml)	T lubricant (125 ml / 4.4 oz)	T Spülmittel (125 ml)	Lubricante T (125 ml)	1

* Pièces de maintenance préconisées.

* Preceding the index number denotes a suggested spare part.

* Bezeichnete Teile sind empfohlene Ersatzteile.

* Piezas de mantenimiento preventivas.

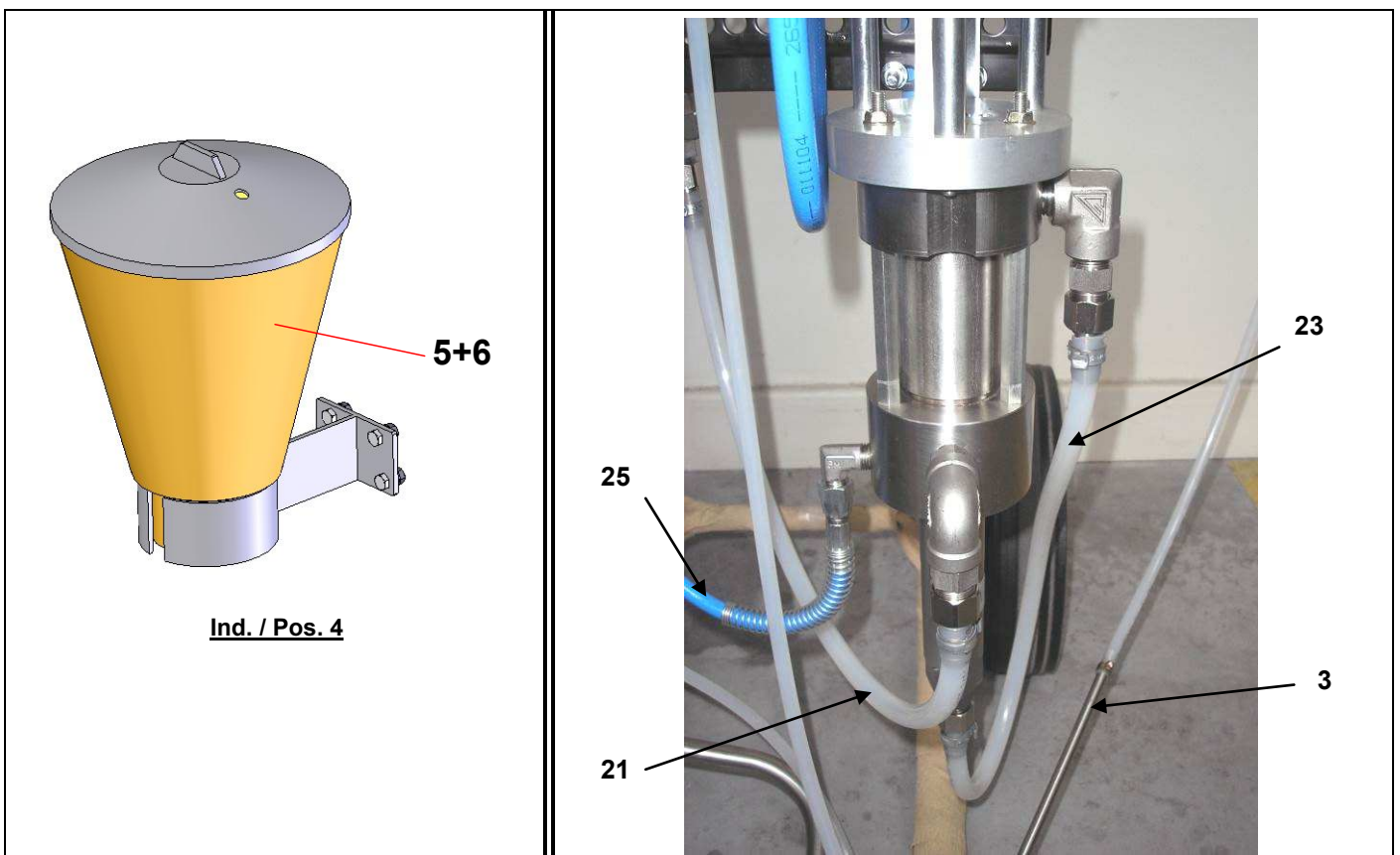

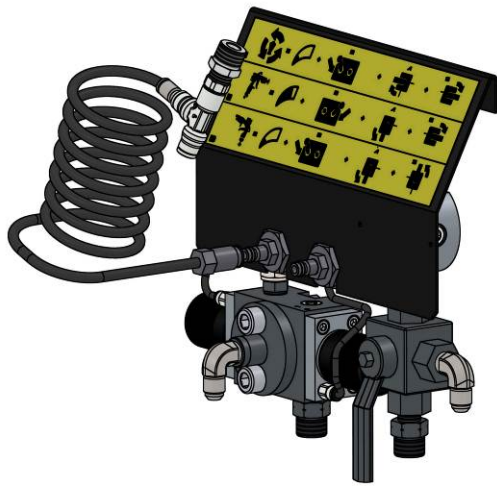

Ind. / Pos. 10 (☞ Doc / Dok. 573.333.050)

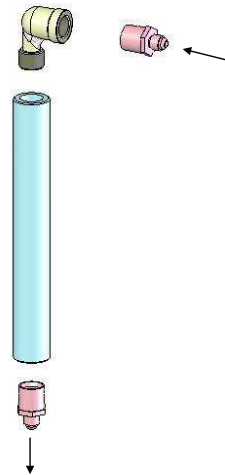

Ind. / Pos. 15 (☞ Doc / Dok. 573.333.050)

OPTIONS - ON REQUEST - OPTIONEN - OPCIONES

Ind	#	Désignation	Description	Bezeichnung	Denominación	Qté
17	-	Tuyau AIRMIX®	AIRMIX® hose	AIRMIX® - Schlauch	Tubería AIRMIX®	1
18	-	Tuyau air	Air hose	Luftschlauch	Tubería de aire	1
19	-	Pistolet Airmix®	Airmix® spray gun	Airmix® Spritzpistole	Pistola Airmix®	1

<p>Doc. 573.332.050 Date/Datum/Fecha : 26/11/20 Annule/Cancel/ Ersetzt/Anula : 14/01/08</p>	<p>Modif. / Änderung : Ind. / Pos. 80 : (# 016 370 000 → 016 370 500) Ind. / Pos. 83 : (# 016 380 000 → NC / NS) + Dessin / Drawing / Zeichung / Dibujo</p>	<p>Pièces de rechange Spare parts list Ersatzteilliste Piezas de repuesto</p>
---	--	--

<p>PU 2160 F</p>	<p>POMPE DE DOSAGE BI-COMPOSANT AIRMIX® FLOWMAX® FLOWMAX® AIRMIX® TWO-COMPONENT PROPORTIONING PUMP FLOWMAX® AIRMIX® ZWEI-KOMPONENTEN DOSIERUNGSPUMPE BOMBA DE DOSIFICACIÓN DOS COMPONENTES AIRMIX® FLOWMAX®</p>
-------------------------	--

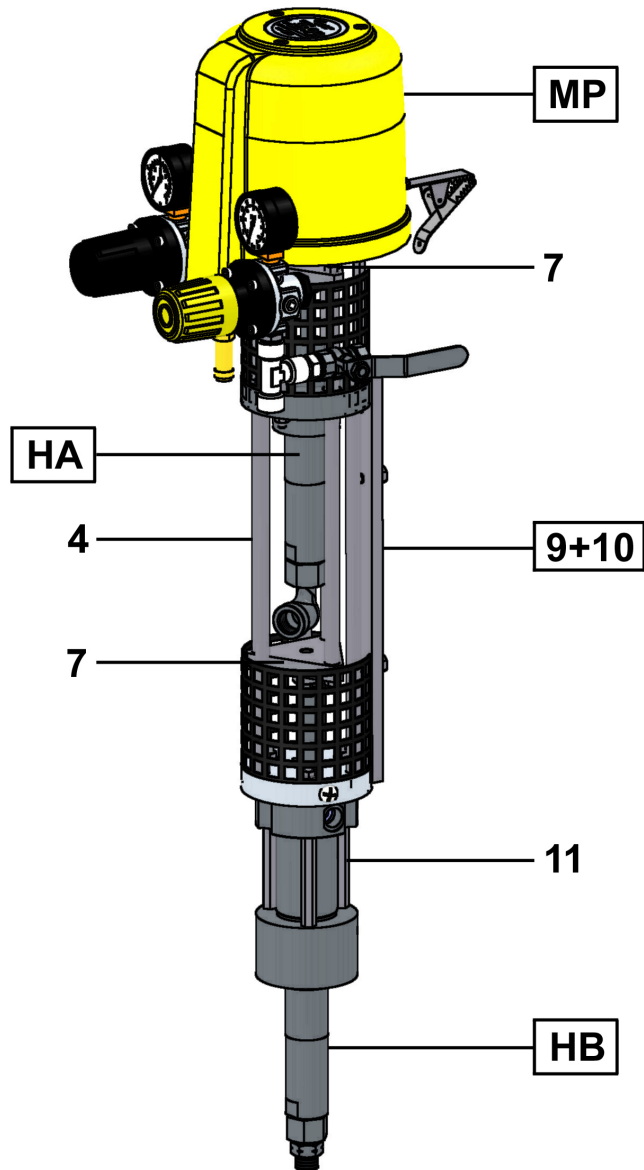

DETAIL / DETALLE

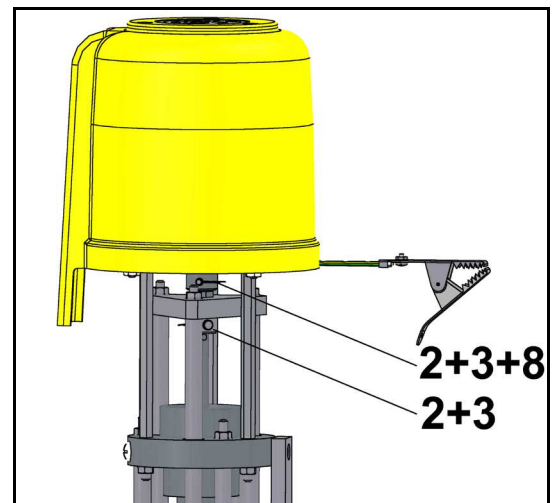

POMPE DE DOSAGE BI-COMPOSANT AIRMIX® FLOWMAX®
FLOWMAX® AIRMIX® TWO-COMPONENT PROPORTIONING PUMP
FLOWMAX® AIRMIX® ZWEI-KOMPONENTEN DOSIERUNGSPUMPE
BOMBA DE DOSIFICACIÓN DOS COMPONENTES AIRMIX®
FLOWMAX®
PU 2160 F

R = 1/1	R = 2/1	R = 5/1	R = 10/1
# 151.586.690	# 151.586.695	# 151.586.710	# 151.586.700

(R : Rapport de dosage / Mix ratio kit / Mischungsverhältnis / Relación dosificación)

Pièces communes - Common parts - Gleiche Teile - Partes comunes

Ind	#	Désignation	Description	Bezeichnung	Denominación	Qté
*MP	144 030 310	Moteur à air (voir détails)	Air motor (see details)	Luftmotor (Siehe Details)	Motor (consultar detalle)	1
*HA	144 030 330	Hydraulique base inox (voir détails)	Base fluid section, stainless steel (see details)	Basis-Hydraulikteil Edelstahl (Siehe Details)	Hidráulica base inox (consultar detalle)	1
1	044 030 303	Tirant moteur	Tie-rod	Verbindungsstange, Motor	Tirante motor	3
2	044 030 117	Axe d'accouplement	Connecting pin	Verbindungsasche	Eje de acoplamiento	3
3	983 020 157	Goupille V - 1,5 x 12	Pin, cotter - 1,5 x 12	Splint, 1,5 x 12	Pasador V - 1,5 x 12	3
4	044 030 304	Tirant	Tie-rod	Verbindungsstange	Tirante	6
6	906 011 501	Ecrou M 6	Nut, M 6	Mutter, M 6	Tuerca M 6	15
7	044 030 302	Bride d'accouplement	Flange, coupling	Flansch, Kupplung	Brida de acoplamiento	2
8	044 030 301	Accouplement	Coupling	Kupplungsstange	Acoplamiento	1
9	044 030 306	Plaque de fixation	Fixing platte	Befestigungsplatte	Placa de fijación	1
10	88 131	Vis CHc M 6x12	Screw, model SHC M 6x12	Schraube CHc M 6x12	Tornillo, tipo CHc M 6x12	2
11	144 030 350	Kit aspiration (voir détails)	Suction kit (see details)	Saugeneinheit (Siehe Details)	Kit aspiración (consultar detalle)	1

Pièces spécifiques - Specific parts - Spezifische Teile - Partes específicas

Ind	#	Désignation	Description	Bezeichnung	Denominación	Qté
*HB	-	Hydraulique catalyseur inox (voir détails)	Catalyst fluid section, stainless steel (see details)	Härter-Hydraulikteil Edelstahl (Siehe Details)	Hidráulica catalizador inox (consultar detalle)	1

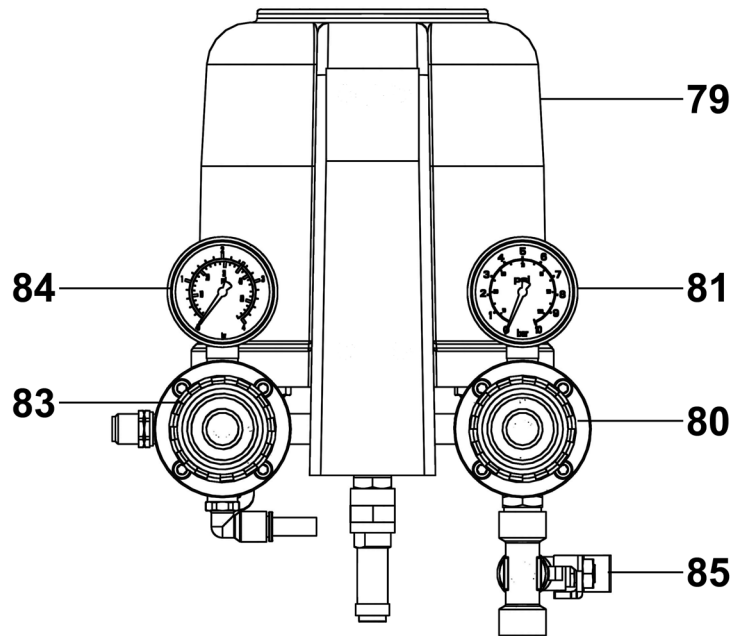

Ind	#	Désignation	Description	Bezeichnung	Denominación	Qté
79	NC / NS	Moteur à air nu (voir Doc. 573.272.050)	Bare air motor (Refer to Doc. 573.272.050)	Nackter Luftmotor (Siehe Dok. 573.272.050)	Motor de aire solo (consultar doc. 573.272.050)	1
-	NC / NS	Equipement d'air	Air supply equipment	Luftausrüstung	Equipo de aire	1
*80	016 370 500	▪ Détendeur d'air 1/4 - 5,5 bar - volant phosphore (voir Doc. 573.288.040)	▪ Air regulator, 1/4 - 5.5 bar / 79.7 psi - (phosphorous knob) (Refer to Doc. 573.288.040)	▪ Druckminderer, 1/4 - 5,5 bar (phosphor Stellglocke) (Siehe Dok. 573.288.040)	▪ Manorreductor, 1/4 - 5,5 bar pomo de color pantone 382 (consultar Doc. 573.288.040)	1
*81	910 011 402	▪ Manomètre 0 - 10 bar	▪ Gauge, 0-10 bar / 0-145 psi	▪ Manometer, 0-10 bar	▪ Manómetro, 0-10 bar	1
*83	NC / NS	▪ Détendeur d'air 1/4 - 3,5 bar - volant noir (voir Doc. 573.288.040)	▪ Air regulator, 1/4 - 3.5 bar / 50.7 psi - black knob (Refer to Doc. 573.288.040)	▪ Druckminderer, 1/4 - 3,5 bar (schwarze Stellglocke) (Siehe Dok. 573.288.040)	▪ Manorreductor, 1/4 - 3,5 bar (pomo negro) (consultar Doc. 573.288.040)	1
*84	910 011 404	▪ Manomètre 0 - 4 bar	▪ Gauge, 0-4 bar / 0-58 psi	▪ Manometer, 0-4 bar	▪ Manómetro, 0-4 bar	1
85	903 090 206	▪ Robinet F 3/8	▪ Valve, F 3/8	▪ Absperrhahn, IG 3/8	▪ Grifo, H 3/8	1

A LA DEMANDE - ON REQUEST - AUF ANFRAGE - A PETICIÓN

Ind	#	Désignation	Description	Bezeichnung	Denominación	Qté
*	144 030 090	Pochette de maintenance (ind. 2, 5(x2), 7, 10(x2), 12, 14, 15, 20) (voir Doc. 573.272.050)	Servicing kit (ind. 2, 5(x2), 7, 10(x2), 12, 14, 15, 20) (Refer to Doc. 573.272.050)	Servicekit (beinhaltet Pos. 2, 5(2x), 7, 10(2x), 12, 14, 15, 20) (Siehe Dok. 573.272.050)	Bolsa de reparación (ind. 2, 5(x2), 7, 10(x2), 12, 14, 15, 20) (consultar doc. 573.272.050)	1

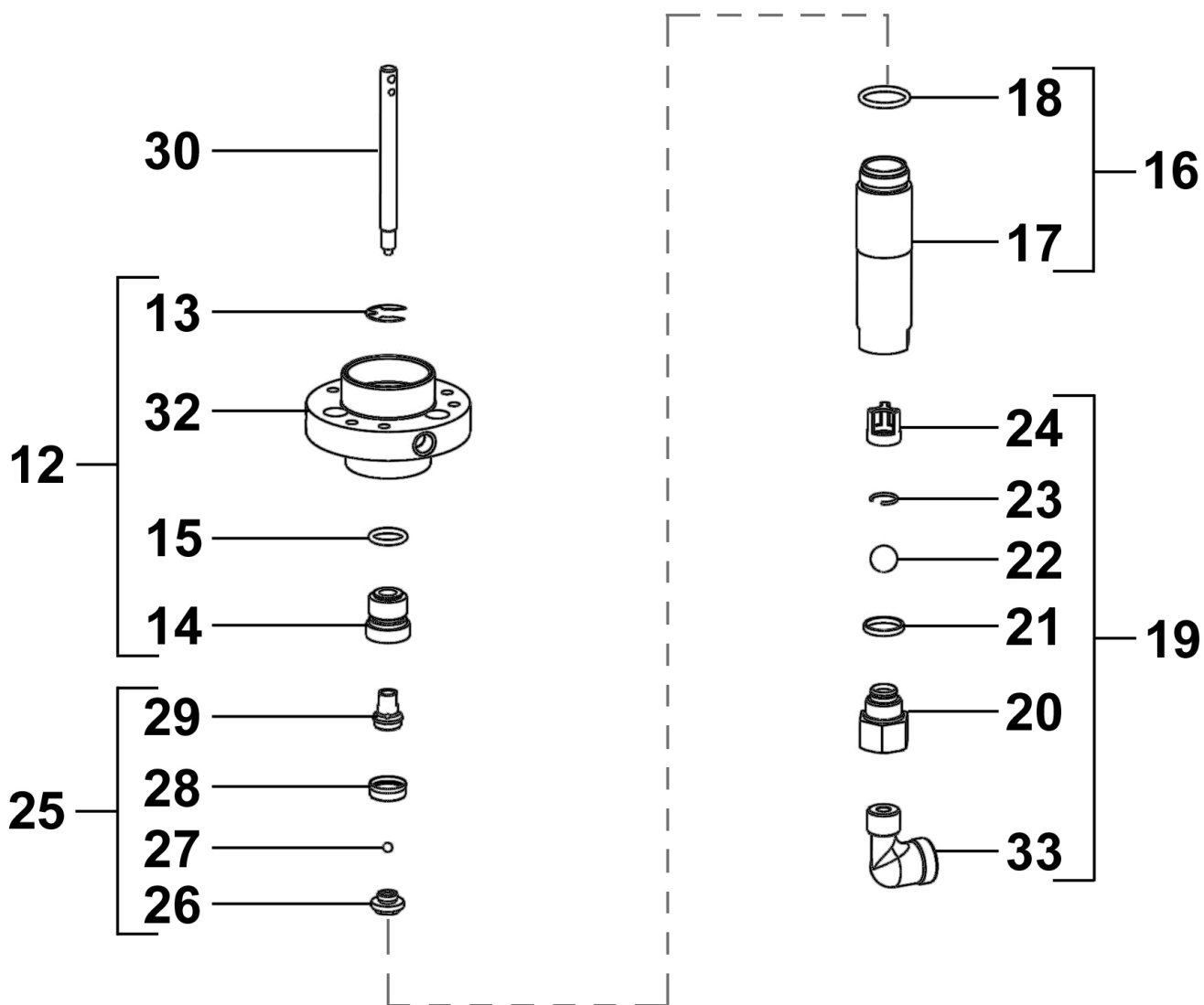

Ind	#	Désignation	Description	Bezeichnung	Denominación	Qté
*12	144 030 157	Cartouche GT équipée	Cartridge kit with GT seal	Packung Edelstahl mit GT-Dichtung	Cartucho GT equipado	1
13	902 201 116	▪ Circlips	▪ Retaining ring	▪ Sicherungsring	▪ Anillo truarc	1
14	NC / NS	▪ Cartouche inox avec joint GT	▪ Cartridge with GT seal	▪ Packung Edelstahl mit GT-Dichtung	▪ Cartucho inox + junta GT	1
15	144 589 500	▪ Joint (x 10)	▪ Seal (x 10)	▪ Dichtring (10 St.)	▪ Junta (bolsa de 10)	1
*16	144 850 153	Cylindre équipé	Cylinder (st.) + seal	Materialzylinder mit O-Ring	Cilindro inox + junta	1
17	NC / NS	▪ Cylindre en inox	▪ Cylinder, stainless steel	▪ Zylinder (Edelstahl)	▪ Cilindro inox	1
18	144 669 901	▪ Joint (x 10)	▪ Seal (x 10)	▪ O-Ring (Satz à 10 St.)	▪ Junta (bolsa de 10)	1
*19	144 030 325	Clapet d'aspiration équipé	Suction valve assembly	Ansaugkugelsitz komplett	Válvula aspiración completa	1
20	NC / NS	▪ Siège de bille	▪ Ball seat	▪ Ansaugkugelsitz	▪ Asiento de bola	1
21	044 586 007	▪ Joint	▪ Seal	▪ Dichtring	▪ Junta	1
22	907 414 242	▪ Bille Ø 16 (inox 440C)	▪ Ball Ø 16 (stainless steel, 440C)	▪ Kugel, Ø 16 (Edelstahl 440C)	▪ Bola Ø 16 (inox 440C)	1
23	044 030 163	▪ Jonc d'arrêt	▪ Circlips	▪ Sicherungsring	▪ Clips de tope	1
24	044 030 162	▪ Cage de bille	▪ Ball cage	▪ Kugelkäfig	▪ Jaula de bola	1
*25	144 030 095	Clapet de refoulement équipé	Exhaust valve assembly	Druckventil komplett	Válvula expulsión completa	1
26	044 805 402	▪ Siège	▪ Seat	▪ Druckventilsitz	▪ Asiento	1
27	907 414 208	▪ Bille Ø 5 (inox 440C)	▪ Ball Ø 5 (stainless steel, 440C)	▪ Kugel Ø 5 (Edelstahl 440C)	▪ Bola Ø 5 (inox 440C)	1
28	044 765 503	▪ Joint de clapet en PFA	▪ Valve seal, PFA	▪ Kolbenmanschette, PFA	▪ Junta de válvula en PFA	1
29	044 030 152	▪ Support de clapet	▪ Valve holder	▪ Druckventilgehäuse	▪ Soporte de válvula	1
30	044 030 151	Tige de piston produit	Fluid piston rod	Kolbenstange	Eje de pistón producto	1
32	044 030 321	Bride sortie produit	Fluid outlet flange	Flansch	Brida salida producto	1
-	905 210 403	Coude MF 1/2 BSP inox	Elbow, MF 1/2, stainless steel	Rohrwinkel, Edelstahl AG 1/2 - IG 1/2	Codo inox MH 1/2	1

A LA DEMANDE - ON REQUEST - AUF ANFRAGE - A PETICIÓN

Ind	#	Désignation	Description	Bezeichnung	Denominación	Qté
*	144 030 091	Pochette de joints (ind. 3, 15, 18, 21, 22, 23, 27, 28)	Package of seals (ind. 3, 15, 18, 21, 22, 23, 27, 28)	Dichtungssatz (beinhaltet Pos. 3, 15, 18, 21, 22, 23, 27, 28)	Bolsa de juntas (ind. 3, 15, 18, 21, 22, 23, 27, 28)	1
*	144 030 392	Pochette de maintenance (ind. 12, 20, 24, 26 + pochette de joints : # 144.030.091)	Servicing kit (ind. 12, 20, 24, 26 + package of seals : # 144.030.091)	Servicekit (beinhaltet Pos. 12, 20, 24, 26 + Dichtungssatz : # 144.030.091)	Bolsa de reparación (ind. 12, 20, 24, 26 + Bolsa de juntas : # 144.030.091)	1

R = 1/1 & R = 2/1

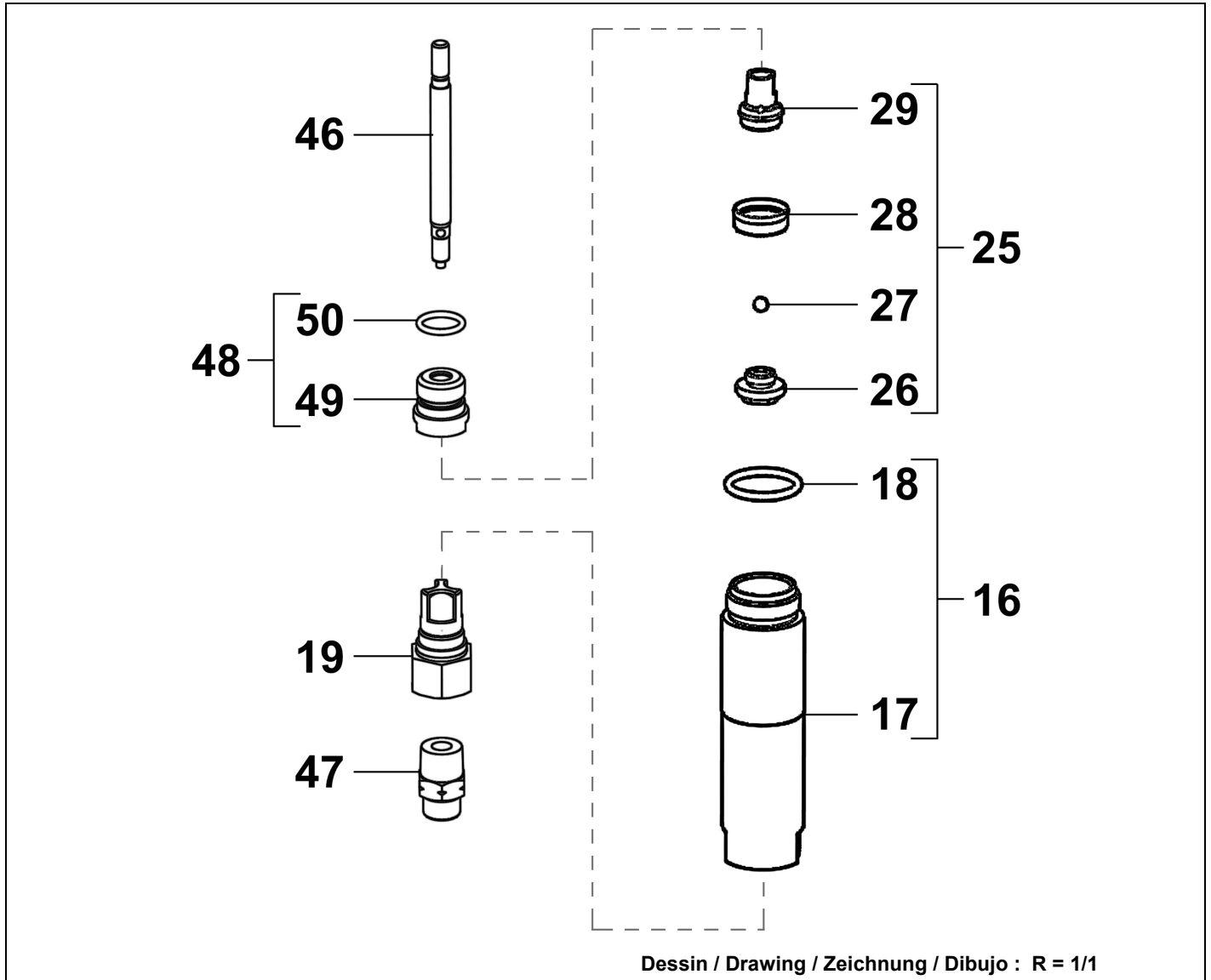
**Pièces communes - Common parts - Gleiche Teile - Partes comunes**

Ind	#	Désignation	Description	Bezeichnung	Denominación	Qté
*19	144 030 325	Clapet d'aspiration (Voir détails - pages 4-5)	Suction valve (See details - pages 4-5)	Ansaugkugelsitz (Siehe Einzelheiten - Seite 4-5)	Válvula aspiración (Ver detalles - páginas 4-5)	1
46	044 030 411	Tige de piston produit	Fluid piston rod	Kolbenstange	Eje de pistón producto	1
47	050 102 418	Raccord M 1/2" - M 18 x 125	Fitting, double male, 1/2" - 18 x 125	Doppelnippel AG 1/2" - M 18 x 1,25 AG	Racor M 1/2" - M 18 x 125	1
48	144 030 415	Cartouche GT équipée	Cartridge kit with GT seal	Packung Edelstahl mit GT-Dichtung	Cartucho GT equipado	1
49	NC / NS	▪ Cartouche	▪ Cartridge	▪ Packung	▪ Cartucho	1
50	144 589 500	▪ Joint (les 10)	▪ Seal (pack of 10)	▪ Dichtring (10 St.)	▪ Junta (bolsa de 10)	1

Pièces spécifiques - Specific parts - Spezifische Teile - Partes específicas : R = 1/1

Ind	#	Désignation	Description	Bezeichnung	Denominación	Qté
*16	144 850 153	Cylindre avec joint (Voir détails - pages 4-5)	Cylinder with seal (See details - pages 4-5)	Materialzylinder mit O-Ring (Siehe Einzelheiten - Seite 4-5)	Cilindro con junta (Ver detalles - páginas 4-5)	1
*25	144 030 095	Clapet de refoulement (Voir détails - pages 4-5)	Exhaust valve assembly (See details - pages 4-5)	Druckventil komplett (Siehe Einzelheiten -Seite 4-5)	Válvula expulsión (Ver detalles - páginas 4-5)	1

Pièces spécifiques - Specific parts - Spezifische Teile - Partes específicas : R = 2/1

Ind	#	Désignation	Description	Bezeichnung	Denominación	Qté
*16	144.030.098	Cylindre avec joint	Cylinder with seal	Materialzylinder mit O-Ring	Cilindro con junta	1
17	NCS / NSS	▪ Cylindre en inox	▪ Cylinder (stainless)	▪ Zylinder (Edelstahl)	▪ Cilindro inox	1
*18	144.669.901	▪ Joint (x 10)	▪ Seal (x 10)	▪ O-Ring (Satz à 10 St.)	▪ Junta (bolsa de 10)	1
*25	144.030.099	Clapet de refoulement	Exhaust valve assembly	Druckventil komplett	Válvula expulsión	1
26	NCS / NSS	▪ Siège	▪ Seat	▪ Sitz	▪ Asiento	1
*27	907 414 208	▪ Bille Ø 5 (inox 440C)	▪ Ball Ø 5 (stainless steel 440C)	▪ Kugel Ø 5 (Edelstahl 440C)	▪ Bola Ø 5 (inox 440C)	1
*28	909 150 231	▪ Joint clapet	▪ Valve seal	▪ Kolbenmanschette	▪ Junta de válvula	1
29	044 030 361	▪ Support clapet	▪ Valve holder	▪ Druckventilgehäuse	▪ Soporte de válvula	1

A LA DEMANDE - ON REQUEST - AUF ANFRAGE - A PETICIÓN

R = 1/1

Ind	#	Désignation	Description	Bezeichnung	Denominación	Qté
*	144 030 397	Pochette de joints (ind. 3, 18, 21, 22, 23, 27, 28, 40x2, 41, 50)	Package of seals (ind. 3, 18, 21, 22, 23, 27, 28, 40x2, 41, 50)	Dichtungssatz (Pos. 3, 18, 21, 22, 23, 27, 28, 40x2, 41, 50)	Bolsa de juntas (ind. 3, 18, 21, 22, 23, 27, 28, 40x2, 41, 50)	1
*	144 030 419	Pochette de maintenance (ind. 20, 24, 26, 48 + pochette de joints : # 144.030.397)	Servicing kit (ind. 20, 24, 26, 48 + package of seals : # 144.030.397)	Servicekit (beinhaltet Pos. 20, 24, 26, 48 + Dichtungssatz : # 144.030.397)	Bolsa de reparación (ind. 20, 24, 26, 48 + Bolsa de juntas : # 144.030.397)	1

R = 2/1

*	144 030 393	Pochette de joints (ind. 3, 18, 21, 22, 23, 27, 28, 40x2, 41, 50)	Package of seals (ind. 3, 18, 21, 22, 23, 27, 28, 40x2, 41, 50)	Dichtungssatz (Pos. 3, 18, 21, 22, 23, 27, 28, 40x2, 41, 50)	Bolsa de juntas (ind. 3, 18, 21, 22, 23, 27, 28, 40x2, 41, 50)	1
*	144 030 418	Pochette de maintenance (ind. 20, 24, 26, 48 + pochette de joints : # 144.030.393)	Servicing kit (ind. 20, 24, 26, 48 + package of seals : # 144.030.393)	Servicekit (beinhaltet Pos. 20, 24, 26, 48 + Dichtungssatz : # 144.030.393)	Bolsa de reparación (ind. 20, 24, 26, 48 + bolsa de juntas : # 144.030.393)	1

(Ind. 40 & 41 : page 11 / Seite 11 / Página 11)

Hydraulique cata / Cata fluid section / Härter-hydraulikteil / Hidráulica cata

(inox / stainless steel / Edelstahl / inox)

R = 5/1 # 144.030.480

(inox 316L / stainless steel, 316L / Edelstahl 316L / inox 316L)

R = 10/1 # 144.030.470

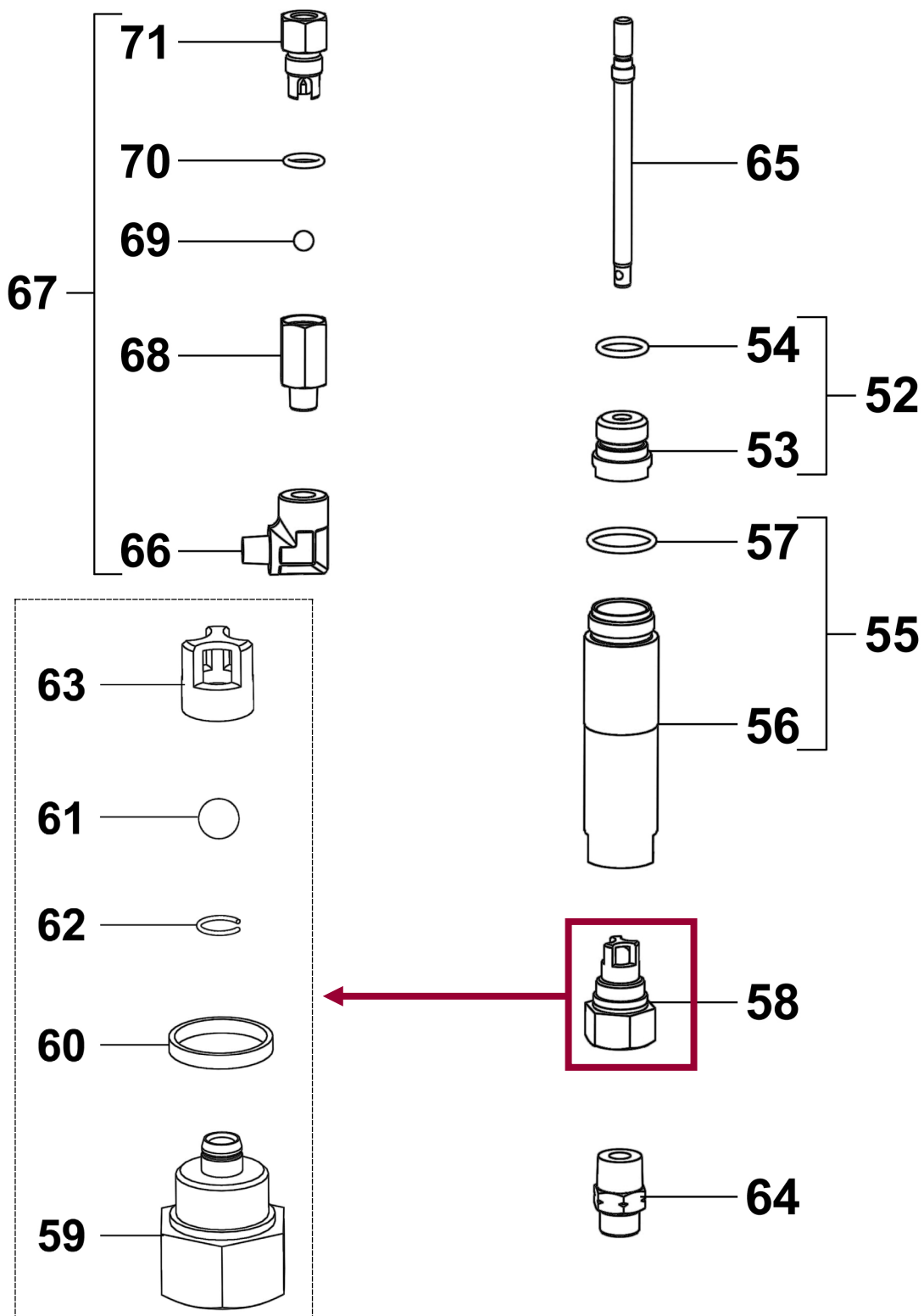

Dessin / Drawing / Zeichnung / Dibujo : R = 10/1

Pièces communes - Common parts - Gleiche Teile - Partes comunes

Ind	#	Désignation	Description	Bezeichnung	Denominación	Qté
*55	144 030 379	Cylindre avec joint	Cylinder with seal	Materialzylinder mit O-Ring	Cilindro con junta	1
56	NC / NS	▪ Cylindre en inox	▪ Cylinder (stainless)	▪ Zylinder (Edelstahl)	▪ Cilindro inox	1
57	909 420 705	▪ Joint	▪ Seal	▪ O-Ring	▪ Junta	1
*58	144 030 474	Clapet d'aspiration équipé	Suction valve assembly	Ansaugkugelsitz komplett	Válvula aspiración completa	1
59	NC / NS	▪ Siège de bille	▪ Ball seat	▪ Ansaugkugelsitz	▪ Asiento de bola	1
60	044 030 478	▪ Joint	▪ Seal	▪ Dichtring	▪ Junta	1
61	907 414 623	▪ Bille Ø 9,52, inox 316L	▪ Ball Ø 9,52 / 3/8" (stainless steel 316L)	▪ Kugel, Ø 9,52 (Edelstahl 316L)	▪ Bola Ø 9,52, inox 316L	1
62	044 030 376	▪ Jonc d'arrêt	▪ Circlips	▪ Sicherungsring	▪ Clips de tope	1
63	044 030 378	▪ Cage de bille	▪ Ball cage	▪ Kugelkäfig	▪ Jaula de bola	1
64	050 102 418	Raccord M 1/2" - M 18 x 125	Fitting, double male, 1/2" - 18 x 125	Doppelnippel AG 1/2" - M 18 x 1,25 AG	Racor M 1/2" - M 18 x 125	1
66	905 210 405	Coude MF 1/4	Elbow, MF 1/	Rohrwinkel, AG 1/4 - IG 1/4	Codo MH 1/4	1
*67	155 490 010	Clapet anti-retour	Non-return valve	Rückschlagventil	Válvula anti retorno	1
68	NC / NS	▪ Support siège	▪ Seat holder	▪ Sitzgehäuse	▪ Soporte de asiento	1
69	907 414 623	▪ Bille Ø 9,52, inox 316L	▪ Ball Ø 9,52 / 3/8" (stainless steel 316L)	▪ Kugel, Ø 9,52 (Edelstahl 316L)	▪ Bola Ø 9,52, inox 316L	1
70	909 420 703	▪ Joint	▪ Seal	▪ Dichtring	▪ Junta	1
71	NC / NS	▪ Clapet	▪ Valve	▪ Ventil	▪ Válvula	1

Pièces spécifiques - Specific parts - Spezifische Teile - Partes específicas : R = 5/1

Ind	#	Désignation	Description	Bezeichnung	Denominación	Qté
*52	144 030 485	Cartouche GT équipée	Cartridge kit with GT seal	Packung Edelstahl mit GT-Dichtung	Cartucho GT equipado	1
53	NC / NS	▪ Cartouche	▪ Cartridge	▪ Packung	▪ Cartucho	1
54	909 420 704	▪ Joint	▪ Seal	▪ Dichtring	▪ Junta	1
65	044 030 481	Tige de piston produit	Fluid piston rod	Kolbenstange	Eje de pistón producto	1

Pièces spécifiques - Specific parts - Spezifische Teile - Partes específicas : R = 10/1

Ind	#	Désignation	Description	Bezeichnung	Denominación	Qté
*52	144 030 475	Cartouche GT équipée	Cartridge kit with GT seal	Packung Edelstahl mit GT-Dichtung	Cartucho GT equipado	1
53	NC / NS	▪ Cartouche	▪ Cartridge	▪ Packung	▪ Cartucho	1
54	909 420 704	▪ Joint	▪ Seal	▪ Dichtring	▪ Junta	1
65	044 030 471	Tige de piston produit	Fluid piston rod	Kolbenstange	Eje de pistón producto	1

A LA DEMANDE - ON REQUEST - AUF ANFRAGE - A PETICIÓN

R = 5/1

Ind	#	Désignation	Description	Bezeichnung	Denominación	Qté
*	144 030 395	Pochette de joints (ind. 3, 40x2, 41, 54, 57, 60, 61, 62, 69, 70)	Package of seals (ind. 3, 40x2, 41, 54, 57, 60, 61, 62, 69, 70)	Dichtungssatz (beinhaltet Pos. 3, 40x2, 41, 54, 57, 60, 61, 62, 69, 70)	Bolsa de juntas (ind. 3, 40x2, 41, 54, 57, 60, 61, 62, 69, 70)	1
*	144 030 489	Pochette de maintenance (ind. 52, 59, 63, 68 + pochette de joints : # 144.030.395)	Servicing kit (ind. 52, 59, 63, 68 + Package of seals: # 144.030.395)	Servicekit (beinhaltet Pos. 52, 59, 63, 68 + Dichtungssatz : # 144.030.395)	Bolsa de reparación (ind. 52, 59, 63, 68 + bolsa de juntas : # 144.030.395)	1

R = 10/1

Ind	#	Désignation	Description	Bezeichnung	Denominación	Qté
*	144 030 395	Pochette de joints (ind. 3, 40x2, 41, 54, 57, 60, 61, 62, 69, 70)	Package of seals (ind. 3, 40x2, 41, 54, 57, 60, 61, 62, 69, 70)	Dichtungssatz (beinhaltet Pos. 3, 40x2, 41, 54, 57, 60, 61, 62, 69, 70)	Bolsa de juntas (ind. 3, 40x2, 41, 54, 57, 60, 61, 62, 69, 70)	1
*	144 030 479	Pochette de maintenance (ind. 52, 59, 63, 68 + pochette de joints : # 144.030.395)	Servicing kit (ind. 52, 59, 63, 68 + Package of seals: # 144.030.395)	Servicekit (beinhaltet Pos. 52, 59, 63, 68 + Di- chtungssatz : # 144.030.395)	Bolsa de reparación (ind. 52, 59, 63, 68 + bolsa de juntas : # 144.030.395)	1

(Ind. 40 & 41 : page 11 / Seite 11 / Página 11)

- * Pièces de maintenance préconisées.
- * Preceding the index number denotes a suggested spare part.
- * Bezeichnete Teile sind empfohlene Ersatzteile.
- * Piezas de mantenimiento preventivas.

- N C : Non commercialisé.
- N S : Denotes parts are not serviceable.
- N S : Bezeichnete Teile gibt es nicht einzeln, sondern nur
komplett.
- N S : no suministrado.

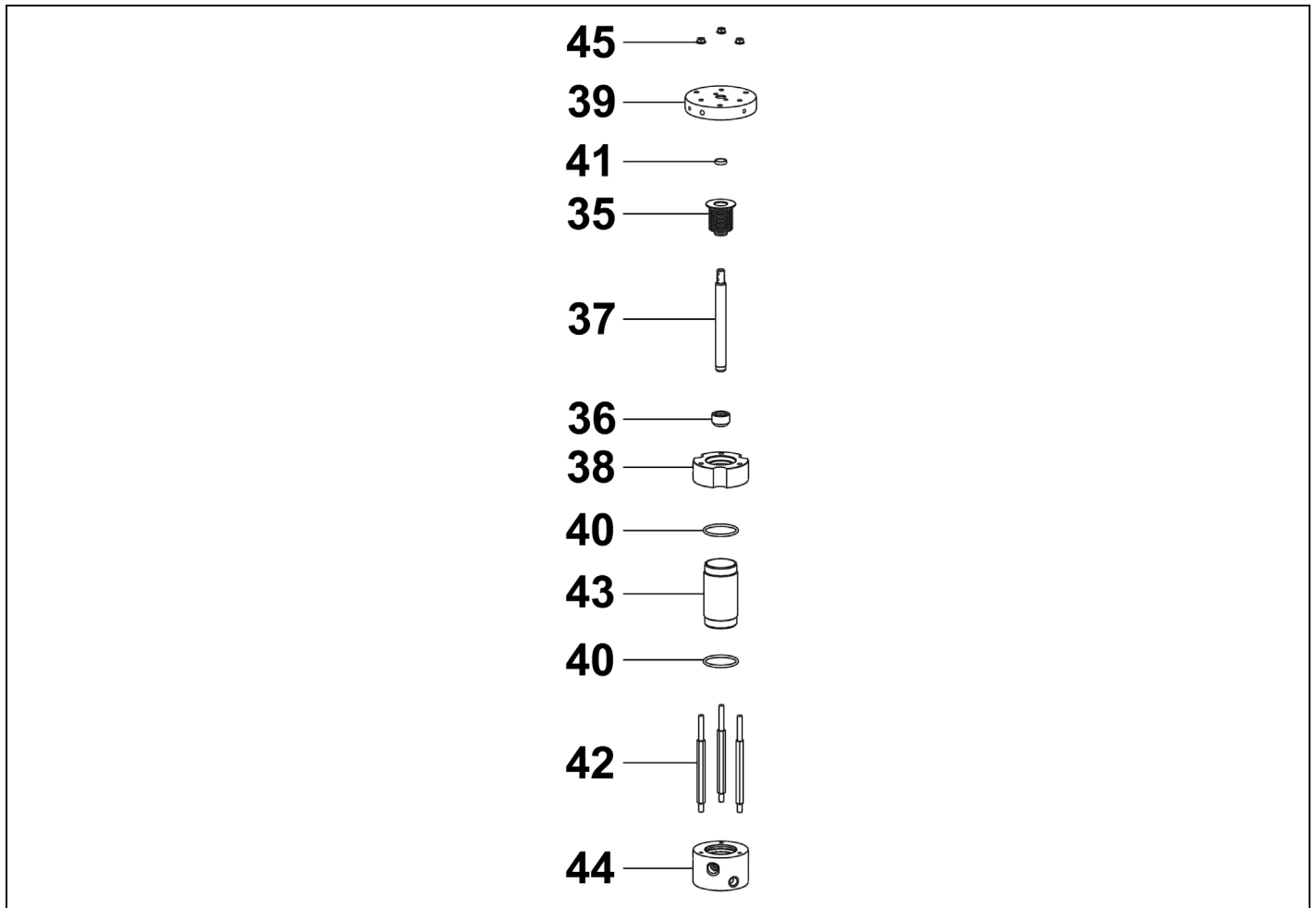

Ind	#	Désignation	Description	Bezeichnung	Denominación	Qté
*	144 030 351	Soufflet avec jupe	Bellows with skirt	Faltenbalg mit Klemmstück	Fuelle con fuelle	1
35	NC / NS	▪ Soufflet	▪ Bellows	▪ Faltenbalg	▪ Fuelle	1
36	044 030 355	▪ Jupe	▪ Skirt	▪ Klemmstück	▪ Faldón	1
37	044 030 359	Tige d'accouplement	Coupling rod	Verbindungsstange	Eje de acoplamiento	1
38	044 030 356	Palier d'aspiration	Suction bearing	Sauglager	Palier de aspiración	1
39	044 030 357	Bride	Flange	Flansch	Brida	1
40	150 040 336	Joint PTFE (les 2)	O-Ring, PTFE (x 2)	O-Ring, PTFE (2 St.)	O-Ring PTFE (x 2)	2
41	044 030 358	Bague d'étanchéité, PTFE	Ring, PTFE	Ring, PTFE	Anillo PTFE	1
42	044 030 353	Tirant	Tie-rod	Verbindungsstange	Tirante	3
43	044 030 354	Cylindre	Cylinder	Zylinder	Cilindro	1
44	044 030 352	Bride produit	Fluid flange	Flansch	Brida producto	1
45	906 011 501	Ecrou M6	Nut, M 6	Mutter, M 6	Tuerca M 6	3

(Ind. 40 & 41) : dans pochettes de joints / in packages of seals / in Dichtungssatz / por bolsas de juntas

Doc. 573.272.050 Date/Datum/Fecha : 27/11/20 Annule/Cancel/ Ersetzt/Anula : 10/10/08	Modif. / Änderung : Mise à jour / Update / Aktualisierung / Actualización + Ind. / Pos. 29 (904 513 003 → 552 482)	Pièces de rechange Spare parts list Ersatzteilliste Piezas de repuesto
--	---	---

MOTEUR A AIR, modèle 700-2	AIR MOTOR, model 700-2	#
LUFTMOTOR, Modell 700-2	MOTOR DE AIRE, tipo 700-2	NC / NS

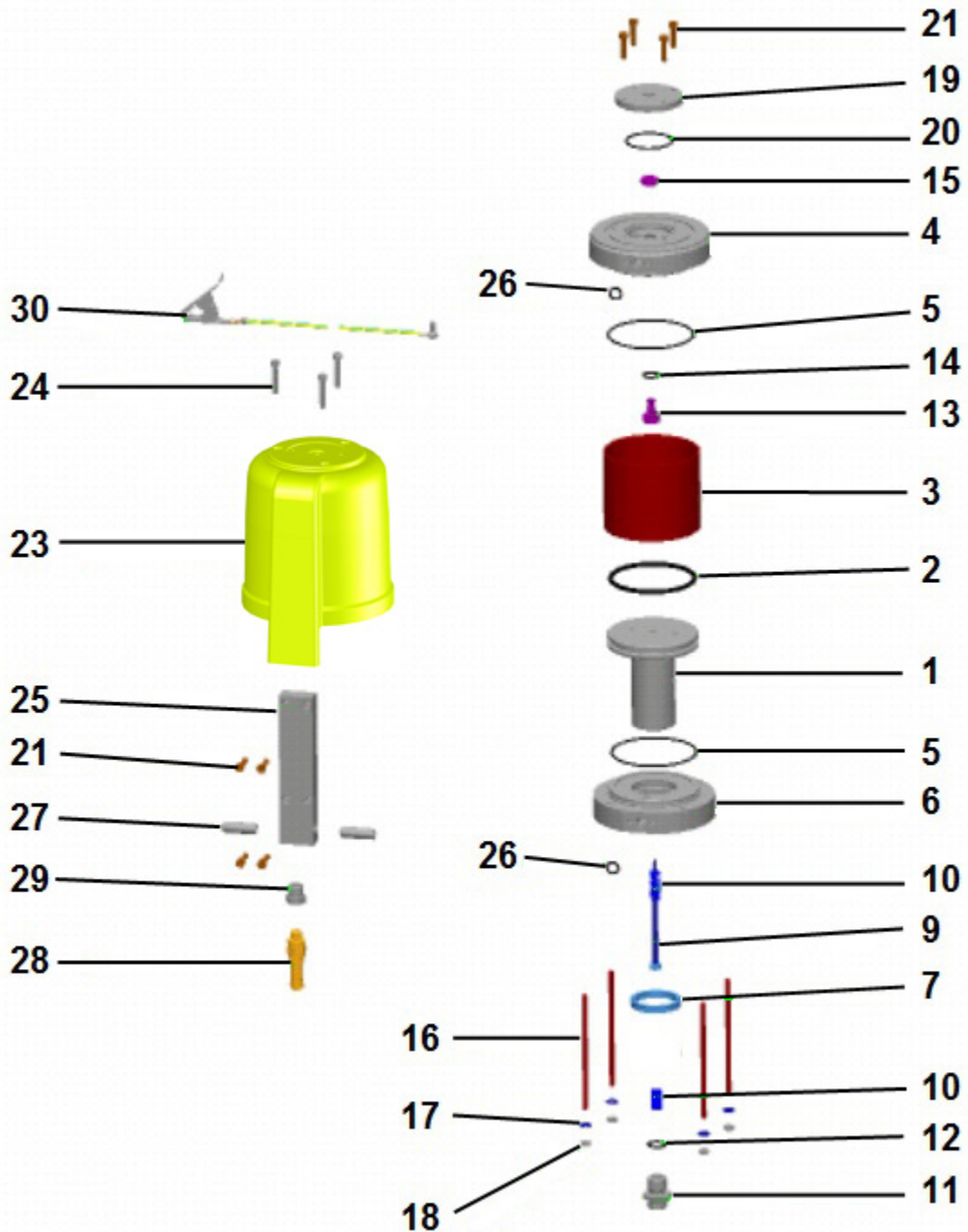

Ind	#	Désignation	Description	Bezeichnung	Denominación	Qté
1	044 030 101	Piston	Piston	Kolben	Pistón	1
2	909 130 447	Bague R 45	Ring, R 45	O-Ring, R 45	Junta R 45	1
3	044 030 102	Cylindre	Cylinder	Zylinder	Cilindro	1
4	044 030 103	Flasque supérieur	Upper flange	Oberer Flansch	Brida superior	1
5	909 420 297	Joint torique	O Ring	Dichtring	Junta O Ring	2
6	044 030 104	Flasque inférieur	Lower flange	Unterer Flansch	Brida inferior	1
*7	144 030 096	Guidage moteur (pochette de 2)	Air motor guide (pack of 2)	Motorführung, (2 St)	Conjunto de dirección motor (bolsa de 2)	1
9	044 030 105	Tige de commande assemblée	Fork assembly, control	Steuerstange	Eje de mando	1
10	050 316 201	Ressort	Spring	Feder	Muelle	2
11	044 030 108	Vis pour accouplement	Screw, coupling	Kupplungsschraube	Tornillo de acoplamiento	1
12	109 130 315	Bague R 13 (les 10)	Ring, R 13 (pack of 10)	O-Ring, R 13 (10 St.)	Junta R 13 (bolsa de 10)	1
13	044 030 110	Porte-joint	Seal, ring	Ventilhalter	Porta- junta	1
14	109 420 812	Joint NBR (x 10)	Ring (x 10)	O-Ring (x 10)	Junta (x 10)	1
15	044 030 111	Clapet	Valve	Umsteuerventil	Válvula de aire	1
16	044 030 112	Tirant moteur	Rod, air motor	Verbindungsbolzen	Tirante motor	4
17	963 040 016	Rondelle MN 6	Washer, MN 6	Scheibe, 6	Arandela MN 6	4
18	953 010 016	Ecrou HM 6	Nut, HM 6	Mutter, M 6	Tuerca HM 6	4
19	044 030 113	Couvercle	Cover	Deckel	Tapa	1
20	909 420 220	Joint	Seal	Dichtring	Junta	1
21	933 151 332	Vis CHc M 6 x 25	Screw, SHC M 6 x 25	Schraube, CHc M 6 x 25	Tornillo CHc M 6 x 25	8
23	044 030 114	Capot	Hood	Glocke	Capó	1
24	933 151 443	Vis CHc M 6x35	Screw, SHC M 6 x 35	Schraube, CHc M 6 x 35	Tornillo CHc M 6 x 35	3
25	051 890 051	Collecteur	Collector	Verbindungsflansch	Colector	1
26	909 130 311	Bague R 9	Ring, R 9	O-Ring, R 9	Junta R 9	2
27	050 080 903	Mamelon 8 x 13	Nipple 8 x 13	Rohnippel 1/4 "	Racor 8 x 13	2
28	903 080 401	Soupape de décharge	Discharge-valve	Sicherheitsventil	Válvula de seguridad	1
29	552 482	Réduction M 3/8 BSP - F 1/4 BSP	Fitting M 3/8 BSP - F 1/4 BSP	Reduzienippel M 3/8 BSP - F 1/4 BSP	Reducción M3/8 BSP - F 1/4 BSP	1
30	901 180 024	Câble de mise à la terre	Cable, ground	Erdungskabel	Cable de puesta a tierra	1

Ind	#	Désignation	Description	Bezeichnung	Denominación	Qté
*	144 030 090	Pochette de maintenance (ind. 2, 5(x2), 7, 10(x2), 12, 14, 15, 20)	Servicing kit (ind. 2, 5(x2), 7, 10(x2), 12, 14, 15, 20)	Servicekit (beinhaltet Pos. 2, 5(2x), 7, 10(2x), 12, 14, 15, 20)	Bolsa de reparación (ind. 2, 5(x2), 7, 10(x2), 12, 14, 15, 20)	1

* Pièces de maintenance préconisées.

* Preceding the index number denotes a suggested spare part.

* Bezeichnete Teile sind empfohlene Ersatzteile.

* Piezas de mantenimiento preventivas.

N C : Non commercialisé.

N S : Denotes parts are not serviceable.

N S : Bezeichnete Teile gibt es nicht einzeln, sondern nur komplett.

N S : no suministrado.

Doc. 573.333.050 Date/Datum/Fecha : 27/11/20 Annule/Cancel/ Ersetzt/Anula : 24/02/09	Modif. / Änderung : Mise à jour / Update / Aktualisierung / Actualización	Pièces de rechange Spare parts list Ersatzteilliste Piezas de repuesto
--	--	---

PU 2160 F	R = 1/1 - R = 2/1 - R = 5/1	R = 10/1
MANIFOLD / MISCHBLOCK	# 151.586.870	# 151.586.850

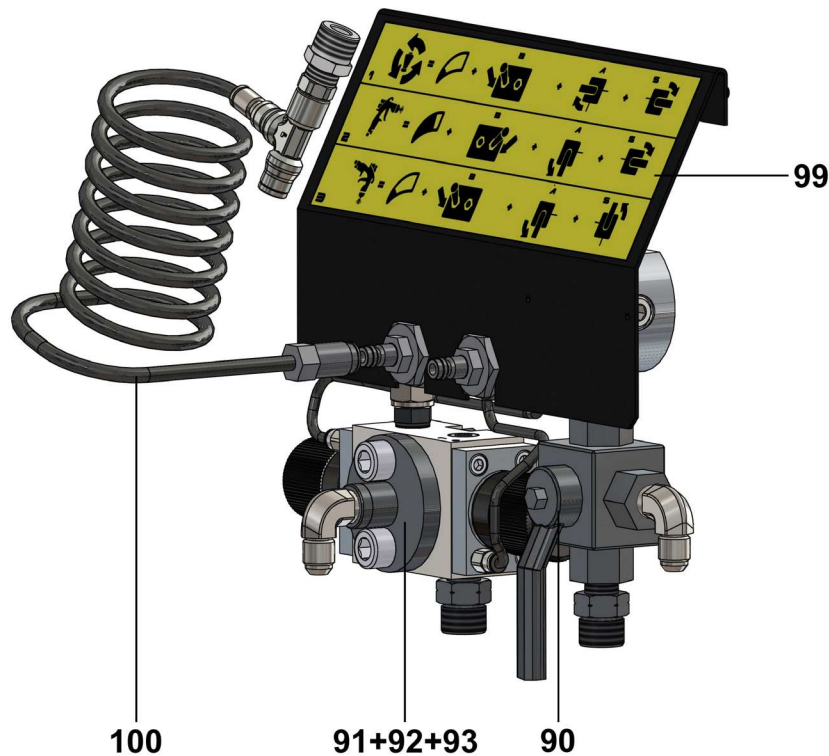

Ind.	#	Désignation	Description	Bezeichnung	Denominación	Qté
*90	903 091 006	Robinet 3 voies F 1/4" (inox 316L)	Three-way valvel, F 1/4" (316L stainless steel)	3-Wege-Kugelhahn 1/4" (Edelstahl, 316L)	Grifo 3 vías H 1/4" (inox 316L)	1
*91	151 586 810	Module AIRMIX® de commutation (200 bar)	Intermediate module (200 bar / 2900 psi)	Zwischen Modul (200 bar)	Modulo AIRMIX® intermedio (200 bar)	1
*92	155 536 300	• Vanne AIRMIX 200 bar (inox 316L)	• Valve, AIRMIX (200 bar / 2900 psi) (316 L stainless steel)	• Airmix® -Ventil (200 bar) (Edelstahl 316 L)	• Válvula AIRMIX® (200 bar) (inox 316 L)	2
93	155 536 410	Bride de sortie équipée	Outlet flange assembly	Ausgangsflansch (Materialausgang) kpl.	Brida de salida equipada	1
-	NC / NS	• Bride de sortie nue (inox 316 L)	• Bare outlet flange (316L stainless steel)	• Ausgangsflansch,nackte (Edelstahl 316 L)	• Brida de salida sola (inox 316 L)	1
-	155 535 710	• Joint PTFE (les 10)	• PTFE seal (x 10)	• PTFE-Dichtung (10 St.)	• Junta PTFE (x 10)	1
99	049 020 137	Etiquette	Sticker	Etikett	Etiqueta	1
100	91 639	Tube spiral	Spiral tube	Spiralförmige Röhre	Tubo espiral	1

PIECES SPECIFIQUES - SPECIFIC PARTS - SPEZIFISCHE TEILE - PARTES ESPECÍFICAS

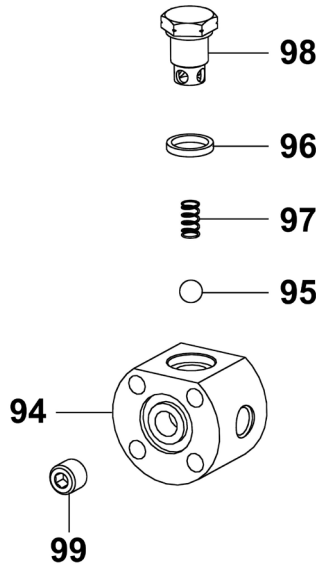

☞ PU 2160 F (R = 1/1 - R = 2/1 - R = 5/1)

Ind.	#	Désignation	Description	Bezeichnung	Denominación	Qté
*94	151 586 523	Clapet de retenue (inox)	Check valve (st steel)	Rückschlagventil (Edelstahl)	Válvula de retención (inox)	2
*95	907 414 223	• Bille Ø 9,52 (inox 440 C)	• Ball, Ø 9.52 / 3/8 ", (440 C st steel)	• Kugel Ø 9,52, (Edelstahl 440 C)	• Bola Ø 9,52 (inox 440 C)	1
*96	051 470 102	• Joint	• Seal	• Dichtung	• Junta	1
97	050 311 249	• Ressort	• Spring	• Feder	• Muelle	1
98	051 586 536	• Bouchon équipé	• Plug	• Stopfen	• Tapón	1
99	906 314 211	• Bouchon (inox 316L)	• Plug (316L st steel)	• Stopfen (Edelstahl 316 L)	• Tapón (inox 316 L)	1

☞ PU 2160 F (R = 10/1)

Ind	#	Désignation	Description	Bezeichnung	Denominación	Qté
*94	051 586 530	Clapet de retenue (inox 316L)	Check valve (stainless steel 316L)	Rückschlagventil (Edelstahl 316L)	Válvula de retención (inox 316L)	2
*95	907 414 623	• Bille Ø 9,52 (inox 316L)	• Ball Ø 9.52 / 3/8 ", stainless steel (316L)	• Kugel Ø 9,52, Edelstahl (316L)	• Bola Ø 9,52, inox (316L)	1
*96	051 586 532	• Joint	• Seal	• Dichtung	• Junta	1
97	050 311 249	• Ressort	• Spring	• Feder	• Muelle	1
98	051 586 536	• Bouchon équipé	• Plug	• Stopfen	• Tapón	1
99	906 314 211	• Bouchon (inox 316L)	• Plug (316L stainless steel)	• Stopfen (Edelstahl 316 L)	• Tapón (inox 316 L)	1

* Pièces de maintenance préconisées.

* Preceding the index number denotes a suggested spare part.

* Bezeichnete Teile sind empfohlene Ersatzteile.

* Piezas de mantenimiento preventivas.

N C : Non commercialisé.

N S : Denotes parts are not serviceable.

N S : Bezeichnete Teile gibt es nicht einzeln, sondern nur komplett.

N S : no suministrado.

ENSEMBLE MELANGEUR / MIXER ASSEMBLY / MISCHER KOMPLETT / MEZCLADOR EQUIPADO

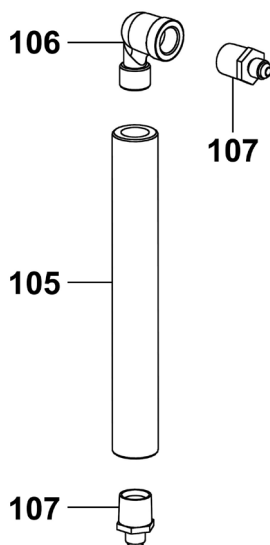

PU 2160 F (R = 1/1, R = 2/1 & R = 5/1)

Ind.	#	Désignation	Description	Bezeichnung	Denominación	Qté
*105	051 531 800	Mélangeur	Mixer	Mischer	Mezclador	1
* -	151 539 902	▪ Serpentin (pochette de 2)	▪ Mixer element (pack of 2)	▪ Mischelement (Satz à 2 St.)	▪ Elemento mezclador (bolsa de 2)	2
106	905 210 403	Coude inox MF 1/2 BSP	Elbow, stainless steel, MF 1/2 BSP	Winkelnippel Edelstahl AG 1/2 BSP - IG 1/2 BSP	Codo de inox, MH 1/2 BSP	1
107	905 210 504	Raccord inox M 1/2 NPT - M 1/2 JIC	Fitting, stainless steel, double male, 1/2 NPT - # 5 JIC (1/2 JIC)	Doppelnippel Edelstahl AG 1/2 NPT - AG 1/2 JIC	Racor de inox M 1/2 NPT - M 1/2 JIC	2

PU 2160 F (R = 10/1)

Ind	#	Désignation	Description	Bezeichnung	Denominación	Qté
105+ 106+ 107	051 586 540	Ensemble mélangeur (inox 316L)	Mixer assembly (stainless steel 316L)	Mischer komplett (Edelstahl 316L)	Mezclador equipado (inox 316L)	1
* -	151 539 902	▪ Serpentin (pochette de 2)	▪ Mixer element (pack of 2)	▪ Mischelement (Satz à 2 St.)	▪ Elemento mezclador (bolsa de 2)	2
106	905 210 403	▪ Coude inox MF 1/2 BSP	▪ Elbow, st steel, MF 1/2 BSP	▪ Winkelnippel Edelstahl AG 1/2 BSP - IG 1/2 BSP	▪ Codo de inox, MH 1/2 BSP	1
107	905 210 504	▪ Raccord inox M 1/2 NPT - M 1/2 JIC	▪ Fitting, st steel, double male, 1/2 NPT - # 5 JIC (1/2 JIC)	▪ Doppelnippel Edelstahl AG 1/2 NPT - AG 1/2 JIC	▪ Racor de inox M 1/2 NPT - M 1/2 JIC	2