



# A28

**AUTOMATIC AIRSPRAY GUN**

 II2G Ex h IIB T6 Gb X

**User's Manual 582190110**

2021-02-14

Index A

Original notice

---

## **SAMES KREMLIN SAS**



13 Chemin de Malacher  
38240 Meylan



[www.sames-kremlin.com](http://www.sames-kremlin.com)



33 (0)4 76 41 60 60

Any communication or reproduction of this document, in any form whatsoever, and any exploitation or communication of its contents is prohibited, except with the express written authorization of **SAMES KREMLIN**.

The descriptions and specifications in this document are subject to change without notice.

**SAMES KREMLIN** 2021

**Table of Contents**

- 1 Safety instructions .....8
  - 1.1 Safety of people .....8
  - 1.2 Integrity of the equipment ..... 15
- 2 EU Declaration of Conformity ..... 16
- 3 Presentation of the A28..... 19
- 4 A28 Pistol exploded view ..... 20
  - 4.1 Dimensions A28 ..... 26
- 5 Equipment identification ..... 27
  - 5.1 Standards applied..... 27
  - 5.2 Description of the ATEX ..... 27
  - 5.3 Visuals of the marking elements ..... 28
- 6 Technical specifications and performance ..... 29
  - 6.1 Technical specifications ..... 29
- 7 Installation ..... 30
  - 7.1 General installation diagram ..... 30
- 8 Operation ..... 32
- 9 Setting ..... 32
- 10 TIPS FOR USING THE GUN..... 33
  - 10.1 Transport ..... 35
  - 10.2 Storage..... 35
- 11 Diagnostic Help/Troubleshooting Guide ..... 36
  - 11.1 Possible symptoms of faults - Causes of faults – Remedies to apply..... 37
  - 11.2 Dismantling and reassembly ..... 38
    - 11.2.1 Dismantle the A28 ..... 38
    - 11.2.2 Replacing the needle tip (item 10)..... 39
    - 11.2.3 Replacing the diaphragm (item 14) ..... 39
    - 11.2.4 Reminder of the greases and adhesives required for the assembly instructions ..... 41

---

**Evolution table**

<b>Object</b>	<b>Review</b>	<b>Date</b>
<b>A28</b>	<b>A</b>	<b>14 02 2021</b>

Dear customer, you have just acquired your new equipment and we thank you for it.

We have taken great care, from design to manufacture, to ensure that this equipment will give you complete satisfaction.

For proper use and optimum availability, please read this instruction manual carefully before commissioning your equipment.

---

## Warranty

SAMES KREMLIN grants a contractual warranty for a period of twelve (12) months from the date of delivery to the Customer, provided that the conditions of use indicated in this technical manual are respected.

In order to be implemented, the warranty request must precisely define the malfunction in question in writing, must be accompanied by the defective Material and/or component and must be informed of the conditions under which the Customer acquired the Material from SAMES KREMLIN.















SAMES KREMLIN will only accept or refuse the implementation of the warranty after analysis of the "defective" Hardware. The warranty granted by SAMES KREMLIN is limited to the replacement of the Hardware in its entirety or the partial replacement of the defective component.

SAMES KREMLIN will only cover the cost of the parts necessary to replace the defective Equipment.

SAMES KREMLIN does not provide any guarantee:

- For defects and deterioration resulting from abnormal storage and/or conservation conditions at the Customer's premises or for maintenance or use of the Equipment that does not comply with the rules of the art or does not respect the prescriptions of this technical manual given to the Customer by SAMES KREMLIN,
  - For defects and damage resulting from replacement parts not approved by SAMES KREMLIN or which have been modified by the Customer,
  - For all damages resulting from negligence or lack of supervision.
  - On behalf of the Client,
  - In the event of normal wear and tear of the Equipment and/or its components or in the event of deterioration or accident resulting from defective and/or abnormal use of it.
-

**Meanings of the pictograms**

 Danger: general signal (user)	 Danger: high pressure	 Explosive materials	 Danger: electricity
 Toxic materials	 Corrosive materials	 Harmful or irritating materials	 Danger: pinching, crushing
 Risk of product release	 Danger: hot parts or surfaces	 Danger: automatic start, moving parts	 Danger: flammability risk
 General obligation	 Grounding	 Consult the instructions manual	 Wearing gloves is mandatory
 Protective helmet	 Hearing protection	 Mandatory respiratory protection	 Safety shoes
 Protective clothing	 Protective visor	 Wearing glasses is mandatory	 Material recycling

---

### Staff qualification



Work on the gun may only be carried out by trained and qualified personnel in accordance with the applicable legal regulations and requirements.

The following conditions must be met:

- The personnel must have special skills and experience in the relevant technical field. This applies in particular to maintenance and repair work on devices relating to the A28 gun.

- Personnel must be familiar with the applicable standards, guidelines, accident prevention regulations and operating conditions.

- Personnel must be authorized by the Safety Officer to perform the required tasks.

- Personnel must be able to recognize and avoid potential hazards.

- The required qualifications of the personnel are subject to different legal regulations depending on the site of implementation. The owner must ensure compliance with the applicable laws.

- Qualified personnel must be familiar with the product safety data sheets that they will be required to use in the operation of the A28.
-

# 1 Safety instructions

## 1.1 Safety of people



The equipment you have is for professional use only. It must only be used for the purpose for which it was intended.

Read carefully the specified recommendations carefully:

- In the technical manuals of the equipment concerned.
- On the labels of the appliances.

Improper use or operation can cause serious injury.

### Training and authorization of operators

Personnel using this equipment must be trained in its use.

The workshop manager must ensure that the operators have fully understood all the instructions and safety rules of this equipment and of the other elements and accessories of the installation.

Only authorized personnel will be allowed to carry out production and maintenance operations on the equipment.

### (Personal Protective Equipment) - Workstation



It is compulsory to wear PPE (Personal Protective Equipment) adapted to the risk situation.

Avoid abnormal postures, maintain a stable position in order to keep your balance at all times, and thus better control the equipment in case of unexpected situations.

Keep the work area tidy and clean. Scattered or piled up parts and tools are sources of accidents.



---

### Pressure hazards



Safety requires that a pressure relief air shut-off valve be installed in the pump motor supply circuit to release trapped air when the supply is shut off. Without

If you do not take this precaution, the residual air in the engine may cause the motor pump to operate and cause a serious accident.

Similarly, a fluid drain valve must be installed on the fluid circuit so that it can be drained (after the air to the motor has been shut off and decompressed) before any work is done on the equipment. These valves must remain closed for air and open for product during the intervention.

---

### Injection hazards



The "LOW PRESSURE" technology requires a maximum of precaution; its exploitation can generate dangerous leaks. In this case, there is a risk of injection of product into exposed parts of the body, which may result in serious injury and risk of amputation:

- An injection of product in the skin or other parts of the body (eyes, fingers...) must be treated urgently by appropriate medical care.
- Never direct the spray towards another person. Never try to stop the jet with your body (hands, fingers...) or with rags or similar.
- Be sure to follow the decompression and purging procedures for any cleaning, checking, equipment maintenance, or gun nozzle cleaning.
- For guns equipped with a safety system, always lock the trigger when the gun is not in use.

---

**Fire - explosion - electric arc - static electricity**



Improper grounding, inadequate ventilation, flames or sparks can cause an explosion or fire that can result in serious injury. To avoid these hazards, especially when using the pumps, it is imperative to:

- To connect the equipment, the parts to be treated, the product and cleaning canisters to the ground,
- Ensure good ventilation,
- To keep the work area clean and free of rags, paper, solvents, Do not operate electrical switches in the presence of fumes or
- during removal,
- Stop application immediately if arcing occurs,
- Store all liquids outside the work area,
- Use products with the highest possible flash point to avoid any
- risk of formation of flammable gases and vapours (consult
- product safety data sheets),
- Equip the drums with a lid to reduce the diffusion of gases and vapours in the cabin.

---

**Toxic hazards**



Toxic products or vapors can cause serious injuries by contact with the body, in the eyes, under the skin, but also by ingestion or inhalation. It is imperative :

- To know the type of product used and the dangers it represents,
  - To store the products to be used in appropriate areas,
  - Contain the product used in the application in a container designed for this purpose,
  - Dispose of the products in accordance with the legislation of the country where the equipment is used,
  - Wear clothing and protection designed for this purpose,
  - Wear goggles, ear protection, gloves, shoes, coveralls and respiratory masks.
-

---

**Attention**

Halogenated hydrocarbon solvents and products containing such solvents must not be used in the presence of **aluminium** or of **zinc**. Failure to follow these instructions may result in an explosion hazard causing serious injury or death.

---

**Material recommendations**

Protectors (engine cover, coupling protector, casings,) are installed for a safe use of the equipment.

The manufacturer cannot be held responsible for personal injury as well as for breakdowns and/or damage to the equipment resulting from the destruction, concealment or total or partial removal protectors.

---

**Pump**

The compatibility of motors and pumps and the special safety instructions must be observed before coupling. These instructions can be found on the pump instruction manuals.

---

The air motor is intended to be coupled to a pump. Never modify the coupling system. Keep hands away from moving parts. The parts involved in the movement must be kept clean. Before starting up or using the pump unit, read the DECOMPRESSION PROCEDURE carefully.

Check that the air release and bleed valves are working properly.

---

---

**Hoses**

- Keep hoses away from traffic areas, moving parts and hot areas.
- Never subject fluid hoses to temperatures above 60°C or below 0°C.
- Do not use the hoses to pull or move the equipment.
- Tighten all fittings, as well as hoses and couplings, before putting the equipment into operation.
- Check the hoses regularly, replace them in case of damage.
- Never exceed the maximum pressure of (PMS) on the hose.

---

**Products used**

Given the diversity of products used by users and the impossibility of identifying all the characteristics of the chemicals, their interactions and SAMES KREMLIN cannot be held responsible for their evolution over time:

- The poor compatibility of the materials in contact,
- The inherent risks to personnel and the environment,
- Wear and tear, malfunctions of the equipment or installations as well as the quality of the finished product.

The user must identify and prevent potential hazards inherent in the products used, such as toxic vapours, fires or explosions. He shall determine the risks of immediate reactions or repeated exposures on the personnel.

SAMES KREMLIN accepts no liability for personal injury or damage to property, whether direct or indirect, caused by the use of chemicals.

---

---

## Environment on site

The equipment is installed on a horizontal, stable and flat floor (e.g. concrete slab).

Non-mobile equipment must be fixed to the ground by suitable fastening devices (spit, screws, bolts, etc.) to ensure their stability during use.



To avoid risks due to static electricity, it is necessary that the equipment and its components are grounded.

- For pumping equipment (pumps, elevators, chassis...), a 2.5 mm section wire is fixed on the equipment. Use this wire to connect the equipment to the general "earth".
- In severe environments (insufficient mechanical protection of the earthing wire, vibrations, mobile equipment, etc.) where damage to the earthing function is likely to occur, the user must replace the 2.5 mm wire supplied with a device that is better suited to the environment (wire with a larger cross-section, earthing braid, fixing by eyelet, etc.).
- Have a qualified electrician check for ground continuity. If ground continuity is not assured, check the terminal, wire, and grounding point. Never operate the equipment until this problem has been resolved.
- The gun must be "grounded" through the air hose or fluid hose. When spraying with a gun equipped with a cup, the air hose must be conductive.
- The materials to be painted must also be "grounded"
- They can be attached to the floor by means of clamps fitted with cables or, if they are suspended, by means of hooks which must be kept clean at all times.

All objects in the work area must also be grounded.

---

## Material marking

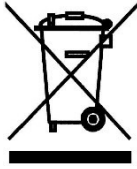

Each appliance is equipped with a sign with the name of the manufacturer, the reference of the appliance, the important information for the use of the appliance (pressure, power...) and sometimes the pictogram shown opposite.

The equipment is designed and manufactured with high quality materials and components that can be recycled and reused.

The EU directive 2012/19/EU applies to all appliances marked with this logo (crossed-out bin).

Ask for more on the collection systems available to you for electrical and electronic appliances.

Follow your local regulations and do not dispose of your old appliances with your household waste. Proper disposal of this old appliance will help prevent negative effects on the environment and human health.

## 1.2 Integrity of the equipment

### Modification of the equipment

Our equipment must not be modified or used for purposes not intended.

Parts and accessories must be supplied or approved exclusively by SAMES KREMLIN.

SAMES KREMLIN cannot be held responsible for personal injury as well as failure and/or damage resulting from modification of the equipment. Any modification of the equipment made by the user and not authorized by SAMES KREMLIN will result in loss of certification.

---

## 2 EU Declaration of Conformity

 578.008.130 2102	<b>SAMES KREMLIN SAS</b> 13, chemin de Malacher 38 240 - MEYLAN - France ☎ : 33 (0)4 76 41 60 60 <b>www.sames-kremlin.com</b>	
<b>FR</b> <b>Pour une utilisation sûre, il est de votre responsabilité de :</b> <ul style="list-style-type: none"> <li>D'installer, d'utiliser, d'entretenir et de réparer l'équipement conformément aux préconisations de SAMES KREMLIN ainsi qu'aux réglementations nationales et/ou locales,</li> <li>Vous assurez que les utilisateurs de cet équipement ont été formés, ont parfaitement compris les règles de sécurité et qu'ils les appliquent.</li> </ul>	<b>UK</b> <b>To ensure safe use of the machinery, it is your responsibility to:</b> <ul style="list-style-type: none"> <li>Install, use, maintain and repair the machinery in accordance with SAMES KREMLIN's recommendations and national and/or local regulations,</li> <li>Make sure that the users of the machinery have received proper training and that they have perfectly understood the safety rules and apply them.</li> </ul>	<b>DE</b> <b>Eine sichere Nutzung setzt voraus, dass Sie:</b> <ul style="list-style-type: none"> <li>die Anlage im Einklang mit den Empfehlungen von SAMES KREMLIN sowie mit den nationalen und/oder lokalen Bestimmungen installieren, verwenden, warten und reparieren,</li> <li>sich vergewissern, dass die Nutzer dieser Anlage angemessen geschult wurden, die Sicherheitsbestimmungen verstanden haben und sie anwenden.</li> </ul>
<b>ES</b> <b>Para una utilización segura, será de su responsabilidad:</b> <ul style="list-style-type: none"> <li>instalar, utilizar, efectuar el mantenimiento y reparar el equipo con arreglo a las recomendaciones de SAMES KREMLIN y a la normativa nacional y/o local,</li> <li>cerciorarse de que los usuarios de este equipo han recibido la formación necesaria, han entendido perfectamente las normas de seguridad y las aplican.</li> </ul>	<b>IT</b> <b>Per un uso sicuro, vi invitiamo a:</b> <ul style="list-style-type: none"> <li>installare, utilizzare, mantenere e riparare l'apparecchio rispettando le raccomandazioni di SAMES KREMLIN, nonché le normative nazionali e/o locali,</li> <li>ascertarsi che gli utilizzatori dell'apparecchio abbiano ricevuto adeguata formazione, abbiano perfettamente compreso le regole di sicurezza e le applichino.</li> </ul>	<b>PT</b> <b>Para uma utilização segura, é da sua responsabilidade:</b> <ul style="list-style-type: none"> <li>Proceder à instalação, utilização, manutenção e reparação do equipamento de acordo com as preconizações de SAMES KREMLIN, bem como com outros regulamentos nacionais e/ou locais aplicáveis,</li> <li>Assegurar-se que os utilizadores do equipamento foram devidamente capacitados, compreenderam perfeitamente e aplicam as devidas regras de segurança.</li> </ul>
<b>NL</b> <b>Voor een veilig gebruik dient u:</b> <ul style="list-style-type: none"> <li>het apparaat te installeren, gebruiken, onderhouden en repareren volgens de door SAMES KREMLIN gegeven aanbevelingen en overeenkomstig de nationale en/of plaatselijke reglementeringen,</li> <li>zeker te stellen dat de gebruikers van dit apparaat zijn opgeleid, de veiligheidsregels perfect hebben begrepen en dat zij die ook toepassen.</li> </ul>	<b>SE</b> <b>För en säker användning av utrustningen ansvarar ni för följande:</b> <ul style="list-style-type: none"> <li>Installera, använd, underhåll och reparera utrustningen enligt anvisningarna från SAMES KREMLIN och enligt nationella och/eller lokala bestämmelser.</li> <li>Försäkra er om att användare av denna utrustning erhållit utbildning, till fullo förstått säkerhetsföreskrifterna och tillämpar dem.</li> </ul>	<b>FI</b> <b>Käytön turvallisuuden varmistamiseksi velvollisuutesi on:</b> <ul style="list-style-type: none"> <li>Noudattaa laitteiston asennuksessa, käytössä, kunnossapidossa ja huollossa SAMES KREMLIN in suosituksia sekä kansallisia ja/tai paikallisia määräyksiä,</li> <li>Varmistaa, että laitteiston käyttäjät ovat koulutettuja ja ymmärtävät täysin turvallisuusmääräykset ja miten niitä sovelletaan.</li> </ul>
<b>PL</b> <b>Dla zapewnienia bezpiecznego użytkownika na użytkownika spoczywa obowiązek:</b> <ul style="list-style-type: none"> <li>Instalowania, użytkowania, konserwacji i naprawy urządzenia zgodnie z zaleceniami firmy SAMES KREMLIN oraz z przepisami miejscowymi,</li> <li>Upewnienia, że wszyscy przeszkoleni użytkownicy urządzenia zrozumieli zasady bezpieczeństwa i stosują się do nich.</li> </ul>	<b>CS</b> <b>Pro bezpečné používání jste povinni:</b> <ul style="list-style-type: none"> <li>Nainstalovat, používat, udržovat a opravovat zařízení v souladu s pokyny firmy SAMES KREMLIN a s národními a/nebo místními legislativními předpisy,</li> <li>Ujistit se, že uživatelé tohoto zařízení byli vyškoleni, že dokonale pochopili bezpečnostní pravidla a že je dodržují.</li> </ul>	<b>SL</b> <b>Za varno uporabo ste dolžni:</b> <ul style="list-style-type: none"> <li>inštalirati, uporabljati, vzdrževati in popravljati opremo po določilih SAMES KREMLIN in v skladu z veljavnimi nacionalnimi in/ali lokalnimi predpisi,</li> <li>poskrbeti, da so uporabniki te opreme ustrezno usposobljeni, poznajo varnostne predpise in da jih upoštevajo.</li> </ul>
<b>SK</b> <b>V záujme bezpečného je vašou povinnosťou:</b> <ul style="list-style-type: none"> <li>nainštalovať, používať, udržiavať a opravovať zariadenie v súlade s odporúčaniami spoločnosti SAMES KREMLIN a národnými a/alebo miestnymi predpismi,</li> <li>uistiť sa, že používatelia tohto zariadenia boli zaškolení, riadne porozumeli pravidlám bezpečnosti a používajú ich.</li> </ul>	<b>HU</b> <b>A biztonságos használat érdekében az Ön felelőssége, hogy:</b> <ul style="list-style-type: none"> <li>a berendezést a SAMES KREMLIN ajánlásainak valamint a nemzeti és/vagy helyi szabályozásoknak megfelelően helyezze üzembe, használja, tartsa karban és javítsa,</li> <li>megbizonyosodjon róla, hogy a berendezés felhasználói képzettek, tökéletesen megértették és alkalmazzák a biztonsági előírásokat.</li> </ul>	<b>RO</b> <b>Pentru o utilizare sigură, este responsabilitatea dvs. să:</b> <ul style="list-style-type: none"> <li>Instalați, utilizați, întrețineți și reparați echipamentul conform instrucțiunilor SAMES KREMLIN precum și reglementărilor naționale și/sau locale,</li> <li>Vă asigurați că utilizatorii acestui echipament au fost instruiți, au înțeles perfect regulile de securitate și le aplică integral.</li> </ul>

Déclaration(s) de conformité au verso de ce document / Declaration(s) of conformity at the back of this document /

Konformitätserklärung(en) auf der Rückseite dieser Unterlage

/ Declaración (es) de conformidad en el reverso de este documento / Dichiarazione/i di conformità sul retro del presente documento

/ Declaração(ões) de conformidade no verso do documento / Conformiteitsverklaring(en) op de keerzijde van dit document /

Försäkran om överensstämmelse på omstående sida av detta dokument / Vaatimustenmukaisuusvakuutukset tämän asiakirjan kääntöpuolella / Deklaracja(e) zgodności na odwrocie dokumentu

/ Prohlášení / o shodě se nachází/nacházejí na zadní straně tohoto dokumentu / Deklaracija(e) o skladnosti na hrbtini strani tega dokumenta / Vyhlásenie/-a o zhode sa nachádzajú na zadnej strane dokumentu / A dokumentum hátlapján szereplő

megfelelőségi nyilatkoz(ok) / Declarații de conformitate pe versoul acestui document





**DECLARATION UE DE CONFORMITE**  
**EU DECLARATION OF CONFORMITY EU-**  
**KONFORMITÄTSEKTLÄRUNG**  
**DECLARACIÓN UE DE CONFORMIDAD**  
**DICHIARAZIONE DI CONFORMITÀ UE**  
**DECLARAÇÃO UE DE CONFORMIDADE EU-**  
**CONFORMITEITSVERKLARING**  
**EU-FÖRSÄKRAN OM ÖVERENSSTÄMELSE EU-**  
**VAATIMUKSEN MUKAISUUSVAKUUTUS**  
**DEKLARACJA ZGODNOŚCI UE**  
**EU PROHLÁŠENÍ O SHODĚ**  
**IZJAVA EU O SKLADNOSTI**  
**VYHLÁSENIE O ZHODE**  
**EU-MEGFELELŐSÉGI NYILATKOZAT**  
**DECLARAȚIA DE CONFORMITATE UE**

Le fabricant / The manufacturer / Der Hersteller / El fabricante / Il produttore / O fabricante / De fabrikant / Tillverkare / Valmistaja / Producent / Výrobce / Proizvajalec / Výrobca / Gyártó / Fabricantul:	<b>SAMES KREMLIN SAS</b> 13, chemin de Malacher 38 240 - MEYLAN - FRANCE Tél. : 33 (0)4 76 41 60 60
--	--

Déclare que le matériel désigné ci-après / Herewith declares that the equipment / erklärt hiermit, dass die / Declara que el material designado a continuación / Dichiaro che il materiale sottoindicato / Declara que o material a seguir designado / verklaart dat de hieronder aangeduide apparatuur / Kungör att den utrustning som anges här nedan / ilmoittaa, että alla mainitut laitteistot / Oświadczam, że wymienione poniżej urządzenia / Prohlašuje, že níže uvedené vybavení / Izjavlja, da je opisana oprema spodaj / Vyhlasuje, že zariadenie uvedené nižšie / Kijelenti, hogy a megjelölt anyag a továbbiakban / Declară că echipamentul precizat mai jos:

**PISTOLETS AUTOMATIQUES DE PULVERISATION PNEUMATIQUES / AIRSPRAY AUTOMATIC SPRAYING GUNS**  
**/ AUTOMATIK LUFTSPRITZPISTOLEN / PISTOLAS AUTOMÁTICAS DE PULVERIZACIÓN NEUMÁTICAS**

A 25
A 25 F
A 28
A 29
A 35
A 3

Est conforme à la législation d'harmonisation de l'Union applicable suivante / Is in conformity with the relevant Union harmonisation legislation / Erfüllt die einschlägigen Harmonisierungsrechtsvorschriften der Union / es conforme con la legislación de armonización pertinente de la Unión / è conforme alla pertinente normativa di armonizzazione dell'Unione / in overeenstemming met de desbetreffende harmonisatiewetgeving van de Unie / med den relevanta harmoniserade unionslagstiftningen / on asiaa koskevan unionin yhdenmukaistamislainsäädännön vaatimusten mukainen / jest zgodny z jednoznacznie wymaganiami unijnego prawodawstwa harmonizacyjnego / Shoduje se s následující příslušnou evropskou harmonizační legislativou / V súlade s harmonizirano zakonodajno Unije / Je v súlade s uplatniteľnými harmonizačnými právnymi predpismi EÚ / Megfelel a következő alkalmazandó uniós harmonizációs szabályozásnak / Este conform cu legislația aplicabilă de armonizare de mai jos

<p>Directive ATEX / ATEX Directive / ATEX Richtlinie / Directiva ATEX / Direttiva ATEX / Diretiva ATEX / ATEX-Richtijn / ATEX-direktivet / ATEX-direktivi / Dyrektywa ATEX / Směrnice ATEX / Direktiva ATEX / ATEX-irányelv / ATEX</p> <p style="text-align: center;">/ Smernica ATEX</p> <p style="text-align: center;"> II 2G Ex h IIB T6 Gb X</p> <p>NF EN ISO 80079-36 Juin 2016 NF EN ISO 80079-37 Juin 2016 NF EN 1127-1 Août 2019</p> <p>Ex h=&gt; Protection par sécurité de construction (c) / Protection by constructional safety (c) / Schutz durch konstruktive Sicherheit (c) / Protección por seguridad constructiva (c) / Protezione per sicurezza costruttiva (c) / Protecção por segurança construtiva (c) / Bescherming door constructieveiligheid (c) / Säker konstruktion (c) / Suojaus rakenteellisella turvallisuuudella (c) / Zabezpieczenie za pomocą bezpieczeństwa konstrukcyjnego (c) / Ochrana bezpečnou konstrukci (c) / Zaščita s konstrukcijsko varnostjo (c) / Ochrana bezpečnou konštrukciou (c) / Szerkezetbiztonsági védelem (c) / Protecție prin securitate constructivă (c)</p> <p style="text-align: center;"><b>INERIS 0080 - 60550 Verneuil-en-Halatte - France / no INERIS-CERN 036594/ 21</b></p>	<p><b>2014/34/UE</b></p>
--	--------------------------

La présente déclaration de conformité est établie sous la seule responsabilité du fabricant / This declaration of conformity is issued under the sole responsibility of the manufacturer / Die alleinige Verantwortung für die Ausstellung dieser Konformitätserklärung trägt der Hersteller / La presente declaración de conformidad se expide bajo la exclusiva responsabilidad del fabricante / La presente dichiarazione di conformità è rilasciata sotto la responsabilità esclusiva del fabbricante / A presente declaração de conformidade é emitida sob a exclusiva responsabilidade do fabricante / Deze conformiteitsverklaring wordt verstrekt onder volledige verantwoordelijkheid van de fabrikant / Denna försäkran om överensstämmelse utfärdas på tillverkarens eget ansvar / Tämä vaatimustenmukaisuusvakuutus on annettu valmistajan yksinomaisella vastuulla / Niniejsza deklaracja zgodności wydana zostaje na wyłączną odpowiedzialność producenta / Toto prohlášení o škodě se vydává na výhradní odpovědnost výrobce / Za izdajo te izjave o skladnosti je odgovoren izključno proizvajalec / Toto vyhlásenie o zhode sa vydáva / na vlastnú zodpovednosť výrobcu / Ezt a megfelelőségi nyilatkozatot a gyártó kizárólagos felelősége mellett adják ti / Prezenta declarație de conformitate este emisă pe răspunderea exclusivă a producătorului.



Hervé WALTER

Directeur Recherche & Développement / Research & Development Director / Direktor für Forschung & Entwicklung / Director de Investigación y Desarrollo / Direttore Ricerca e sviluppo / Diretor de Pesquisa e desenvolvimento / Manager Onderzoek en Ontwikkeling / Direktör för Forskning och Utveckling / Johtaja tutkimus ja kehitys / Dyrektor ds. Badań i rozwoju / Ředitel výzkumu a vývoje / Direktor za raziskave in razvoj / Riaditeľ pre výskum a vývoj / Kutatási és Fejlesztési Igazgató / Director de cercetare și Dezvoltare

Fait à Meylan, le / Established in Meylan, on / Geschehen zu Meylan, am / En Meylan, a / Redatto a Meylan, / Vastgesteld te Meylan, / Utformat i Meylan, den / Meylan, Ranska, / Sporządzono w Meylan, dnia / Meylan, dnia / V Meylanu, / V Meylan dňa / Kelt Meylanban, / Întocmită la Meylan, pe data de 11/02/2021 - 02/11/2021

### 3 Presentation of the A28

#### Usage

#### **A28 HPA automatic spray gun**

The A28 HPA low pressure automatic spray gun features Superlife technology, and is particularly recommended for enamel paints, high solids or solvent free products with an increased life span.

- High transfer rate
  - Exceptional quality of finish
  - Optimized design for high solids and solvent-free products
-

#### 4 A28 Pistol exploded view

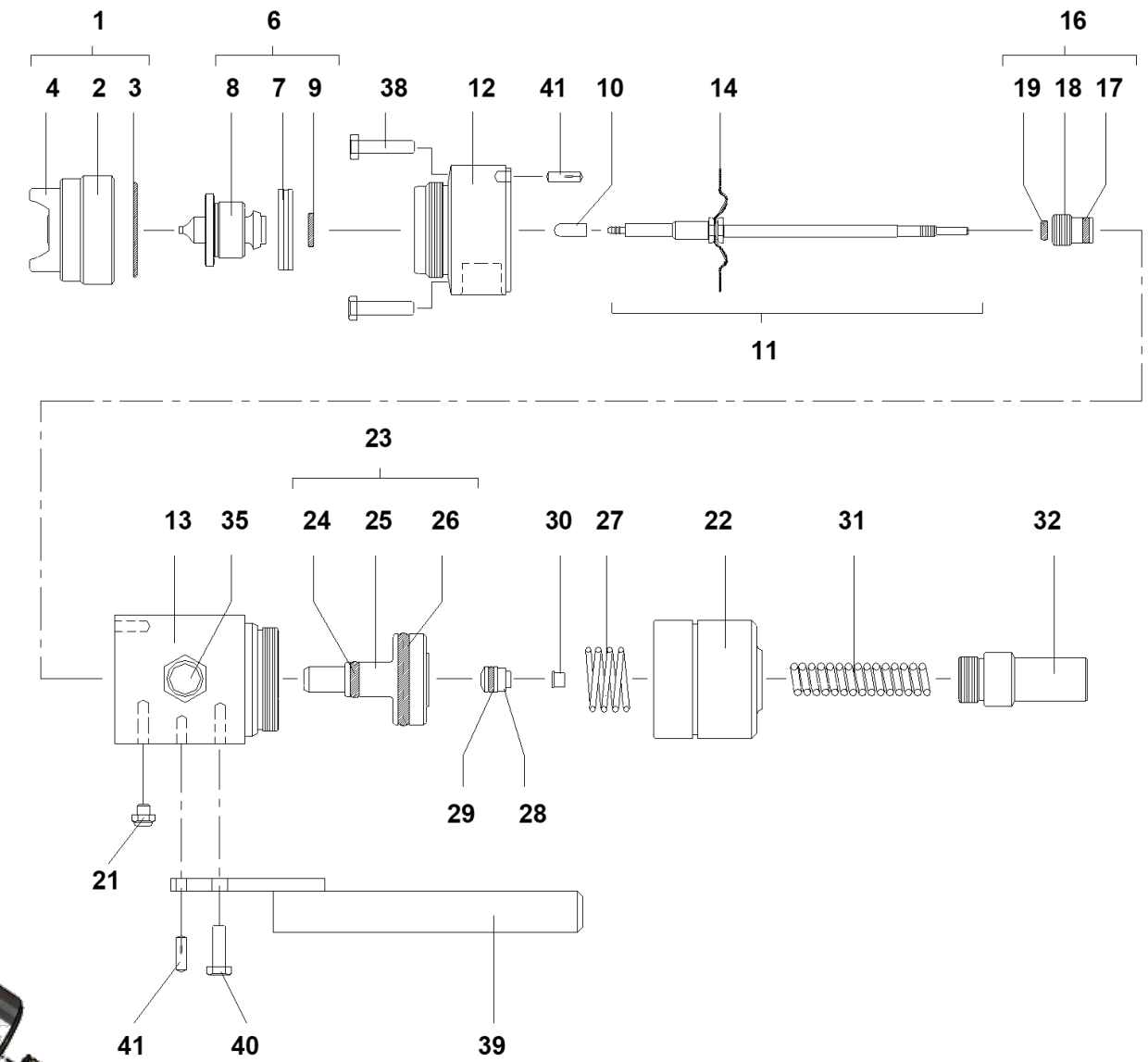
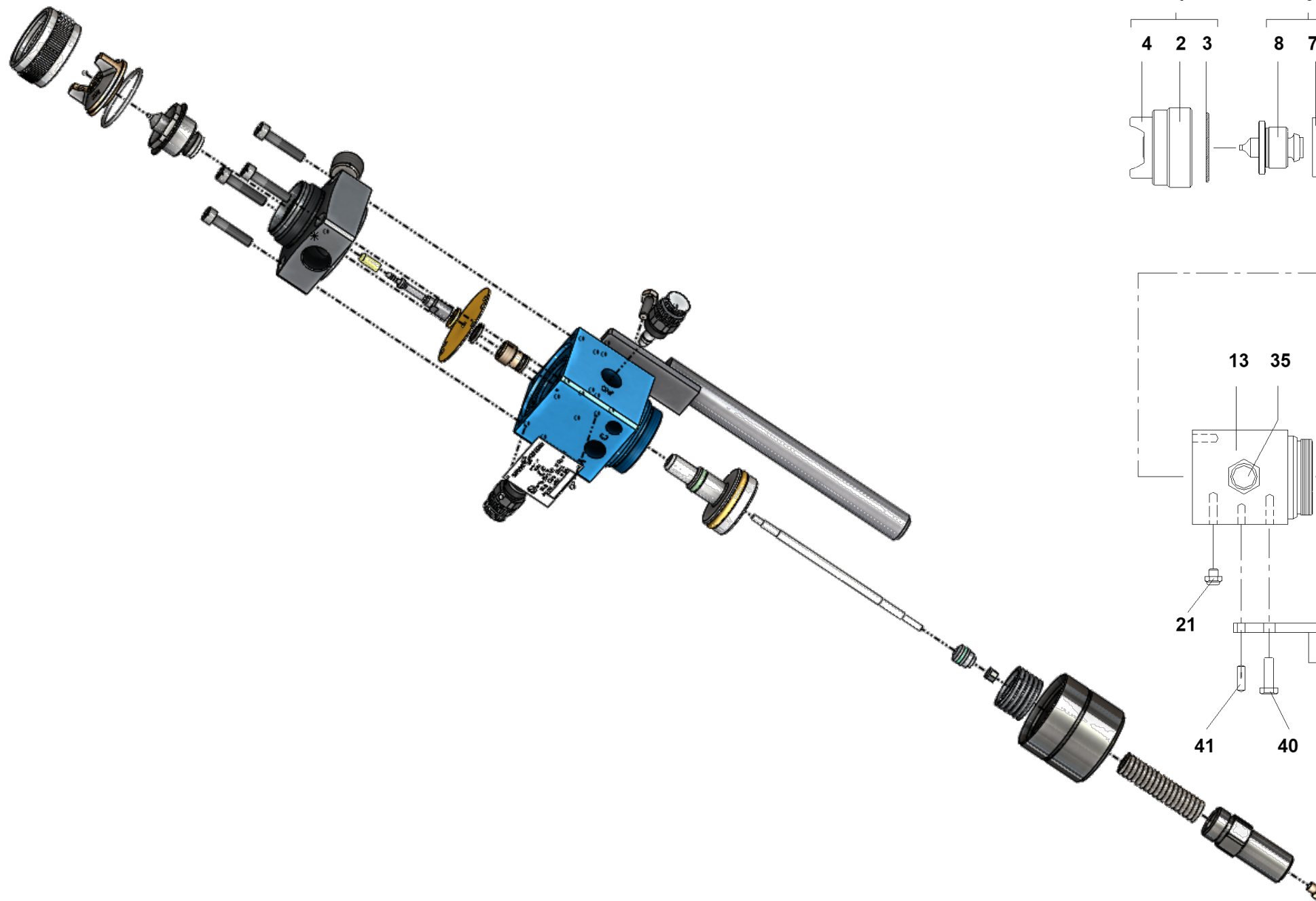

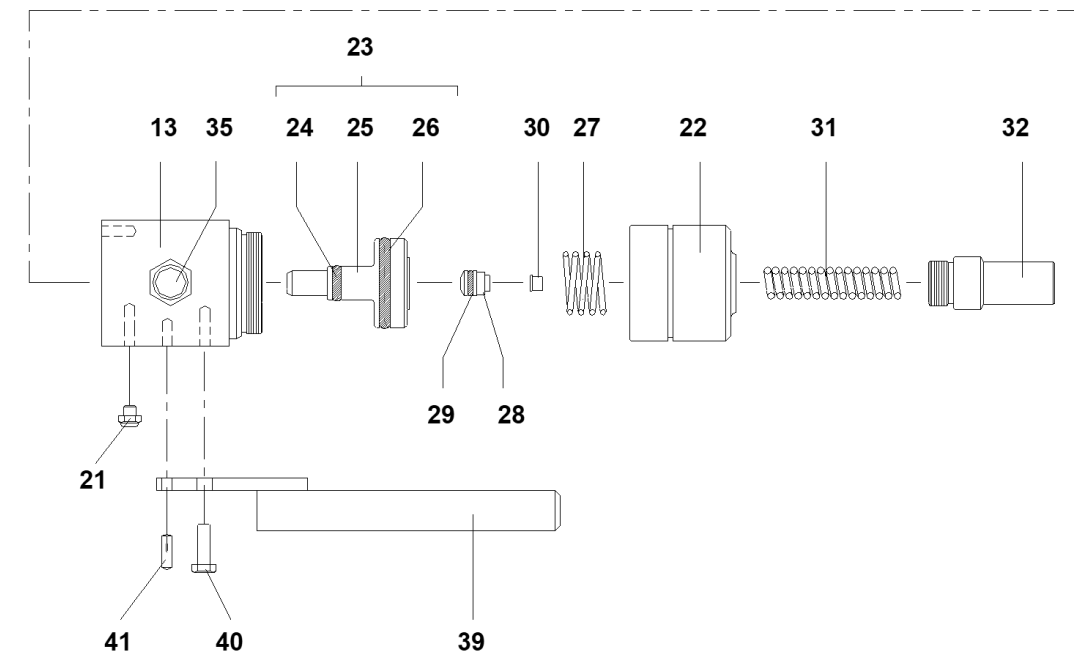
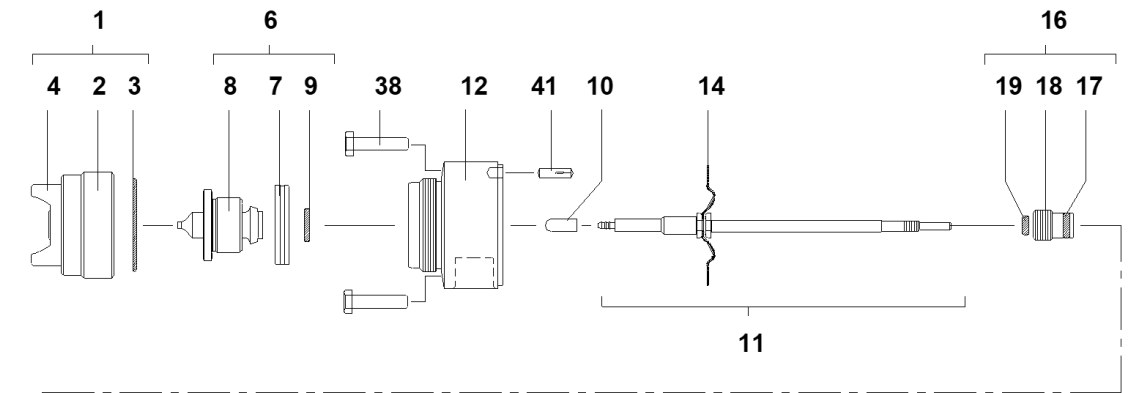
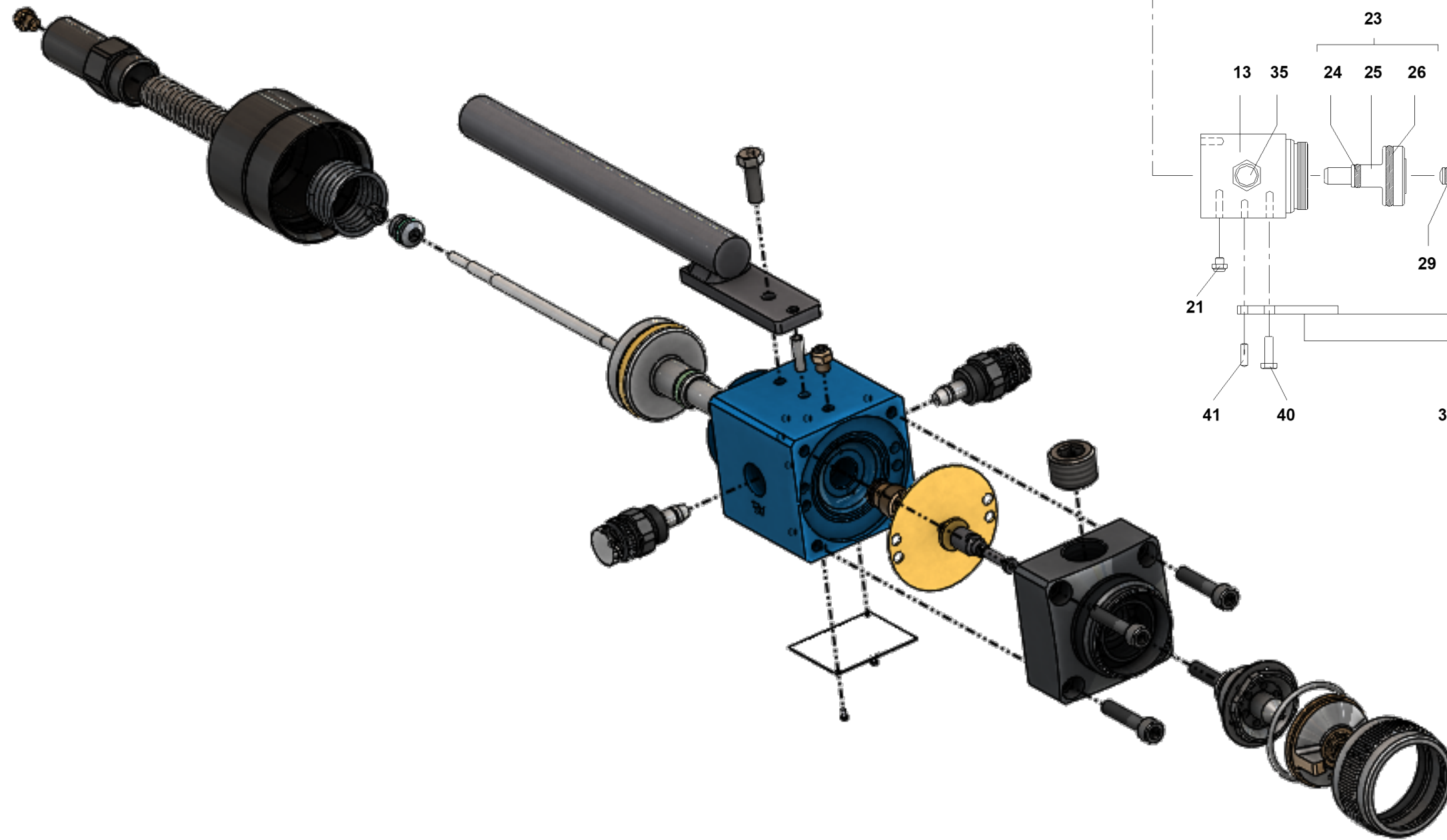

**A 28 (without projector 129.417.000)**

A 28	L (mm)	L ( " )	#
207 Z 23 A	20 - 30	7.87 -	135.417.001
+ 209 Z 23 A	20 - 30	7.87 -	135.417.002
212 Z 23 A	20 - 30	7.87 -	135.417.003
212 N 23 C	20 - 30	7.87 -	135.417.004
215 N 23 C	25 - 35	9.84 -	135.417.005
218 N 23 C	25 - 35	9.84 -	135.417.006
+ 222 R 23	25 - 40	9.84 -	135.417.007
+ 222 R 24	25 - 40	9.84 -	135.417.009

A 28	L (mm)	L ( " )	#
+ 222 R 29	25 - 40	9.84 - 15.75	135.417.011
+ 227 R 23	30 - 45	11.8 - 17.72	135.417.008
+ 227 R 24	30 - 45	11.8 - 17.72	135.417.010
+ 227 R 29	30 - 45	11.8 - 17.72	135.417.012
+ 233 S 23	35 - 50	13.45 - 19.7	135.417.013
+ 233 S 29	35 - 50	13.45 - 19.7	135.417.015
+ 240 S 23	35 - 50	13.45 - 19.7	135.417.014
+ 240 S 29	35 - 50	13.45 - 19.7	135.417.016

**L : Largeur de jet - Fan width - Spritzbreite - Anchura deabanico**

---

**A 28 + HDPE needle tip + 215 N 23 C# 135.417.025**

**Spare parts**

Ind	#	Designation	Qty
* 1	-	Complete head (see table)	1
2	032.020.001	Head ring	1
3	150.040.309	Ring seal (the 10)	1
4	NCS / NSS	Bareheaded	1
* 6	-	Equipped nozzle (see table)	1
7	129.729.902	Dividing ring (the 10)	1
8	NCS / NSS	Nozzle	1
9	129.209.902	Nozzle seal (all 5)	1
* 10a	129.417.005	Needle tip for nozzle 7 to 27 (10 pieces)	1
* 10b	129.417.014	Needle tip for 33 and 40 nozzle (the 10)	1
* 10c	129.417.020	PEHD nozzle tip for 15, 18 (the 5)	1
* 11	129.417.910	Membrane assembly (Ind. 14+30)	1
12	029.417.001	Product body	1
13	029.417.002	Air body	1

---

Ind	#	Designation	Qty
* 16	129.417.200	Needle bearing equipped	1
17	129.971.002	Gasket R5A (the 10)	1
18	NCS / NSS	Needle bearing	1
19	909.130.803	Seal R3	1
21	903.210.501	Muffler	2
22	029.417.009	Cylinder	1
* 23	129.417.100	Equipped piston	1
24	129.251.992	Gasket R8 (the 10)	1
25	NCS / NSS	Piston only	1
26	129.251.993	R22 gasket (the 10)	1
27	050.313.504	Spring for color changer	1
28	029.251.301	Needle trainer	1
29	129.400.915	R5a gasket in FPM (fluorinated elastomers) (the 10)	1
30	029.251.303	Special nut	1
31	050.319.305	Needle spring	1
32	029.417.008	Spring stop	1
35	129.267.300	Air pointer	2
36	129.400.915	Joint (the 10)	1
37	102.202.101	Circlips 5 (the 10)	1
38	934.151.330	Screw CHc M 5 x 25	4
39	029.417.011	Gun holder	1
40	933.011.194	Screw M 5 x 16	1
41	906.120.089	Pin	2
-	905.210.304	Stainless steel plug 3/8 NPT (2nd fluid inlet)	1
50	049.030.021	Flat wrench SAMES KREMLIN	1
51	906.300.101	Brush	1

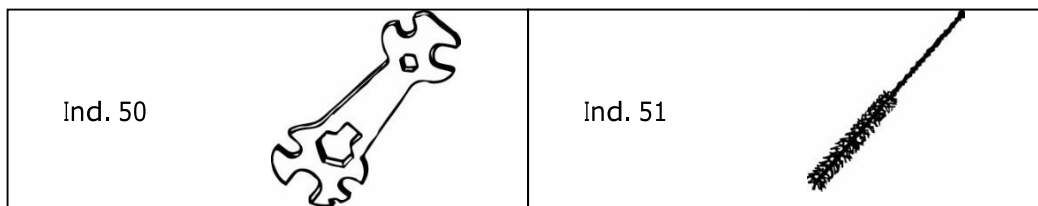

\* Recommended maintenance parts held in stock\*.

N C S: Not sold alone.

Ind	#	Designation	Qty
*	129.417.900	Seal pocket (ind. 9, 17, 19, 21, 24, 26, 29, 36)	1
*	129.417.901	Maintenance kit (ind. 10a + 10b + 11 + 37(x2) + seal kit)	1



## Head and nozzle

Hea	
Type	#
Z 23 A	132.020.550
N 23 C	132.021.750
R 23	132.021.300
R 24	132.021.800
R 29	132.021.400
S 23	132.021.900
S 29	132.021.500

R 29 - S 29      round pattern / jet  
                           rond /  
                           Rundstrahl /  
                           abanico round

Treated			
Type	Ø (mm)	Ø ( " )	#
207 T	0,7	0.027	134.025.050
209 T	0,9	0.035	134.025.100
212 T	1,2	0.047	134.025.200
212 N T	1,2	0.047	134.025.250
215 T	1,5	0.06	134.025.300
218 T	1,8	0.071	134.025.400
222 T	2,2	0.09	134.025.600
227 T	2,7	0.11	134.025.700
233 T	3,3	0.13	134.025.800
240 T	4,0	0.16	134.025.900

## Options

#	Designation	Qty
050.102.648	Stainless steel product connection	1
905.120.902	Elbow fitting (control air) M 1/8 BSP - T 6x8 mm	1
905.120.934	Elbow fitting (control air) M 1/8 BSP - T 8x10 mm	1
050.102.632	Connection (spray air) M 1/4 NPS - M 3/8 NPS	1
029.417.019	Remote air control kit	1

4.1 Dimensions A28

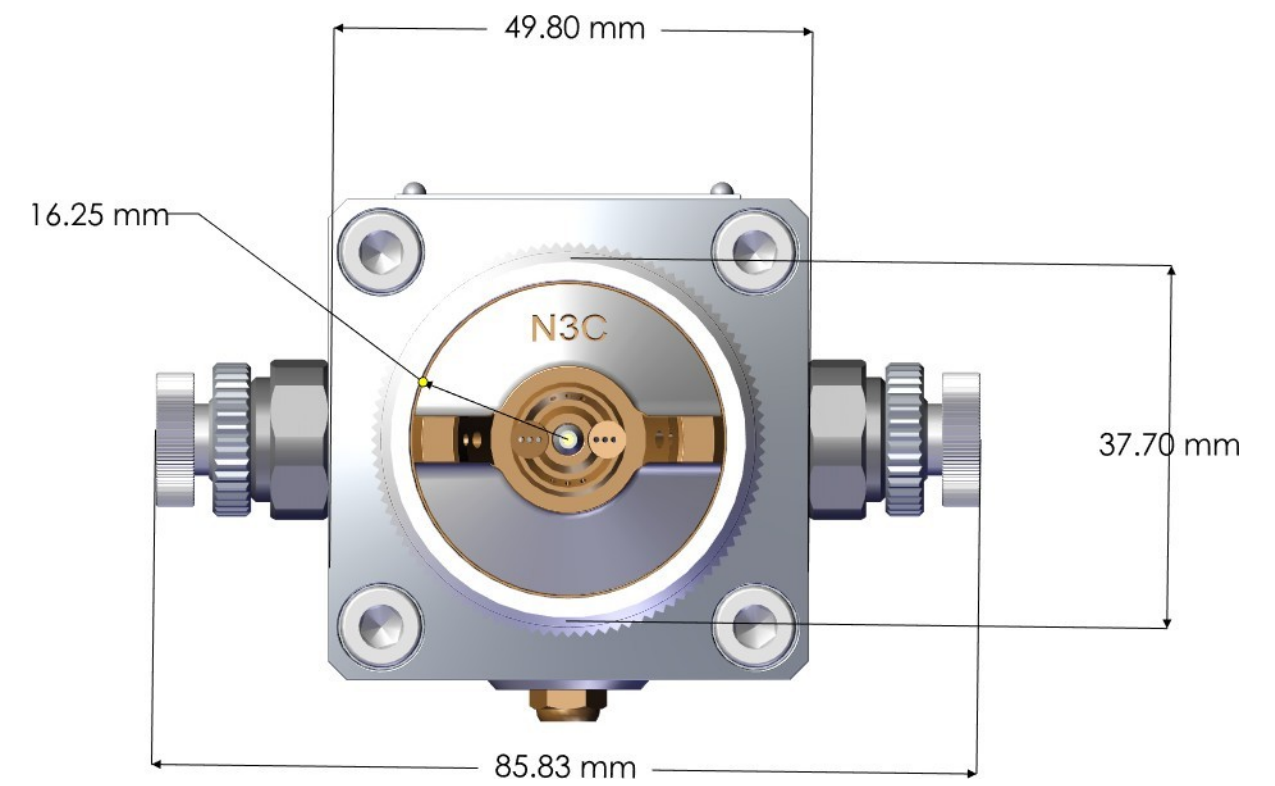
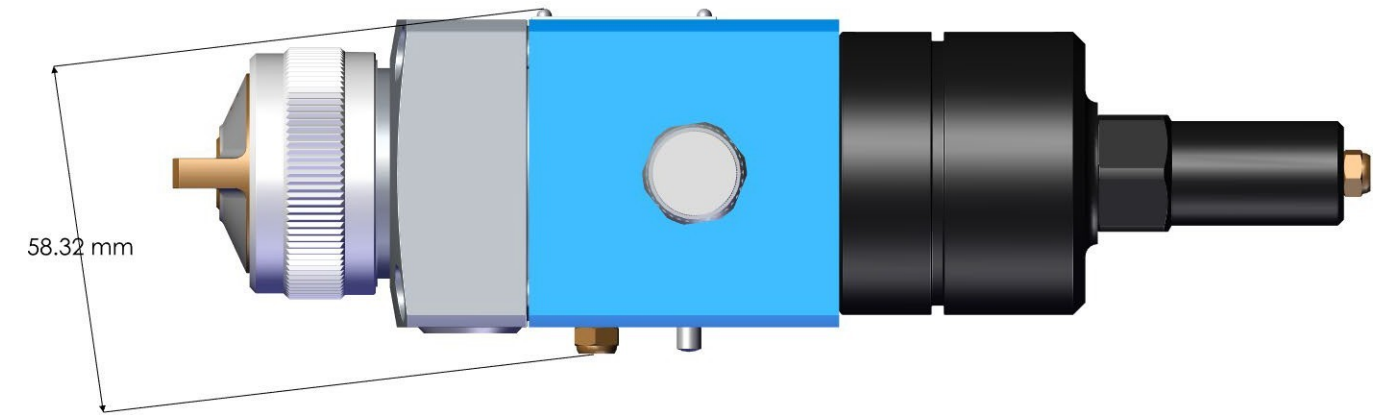
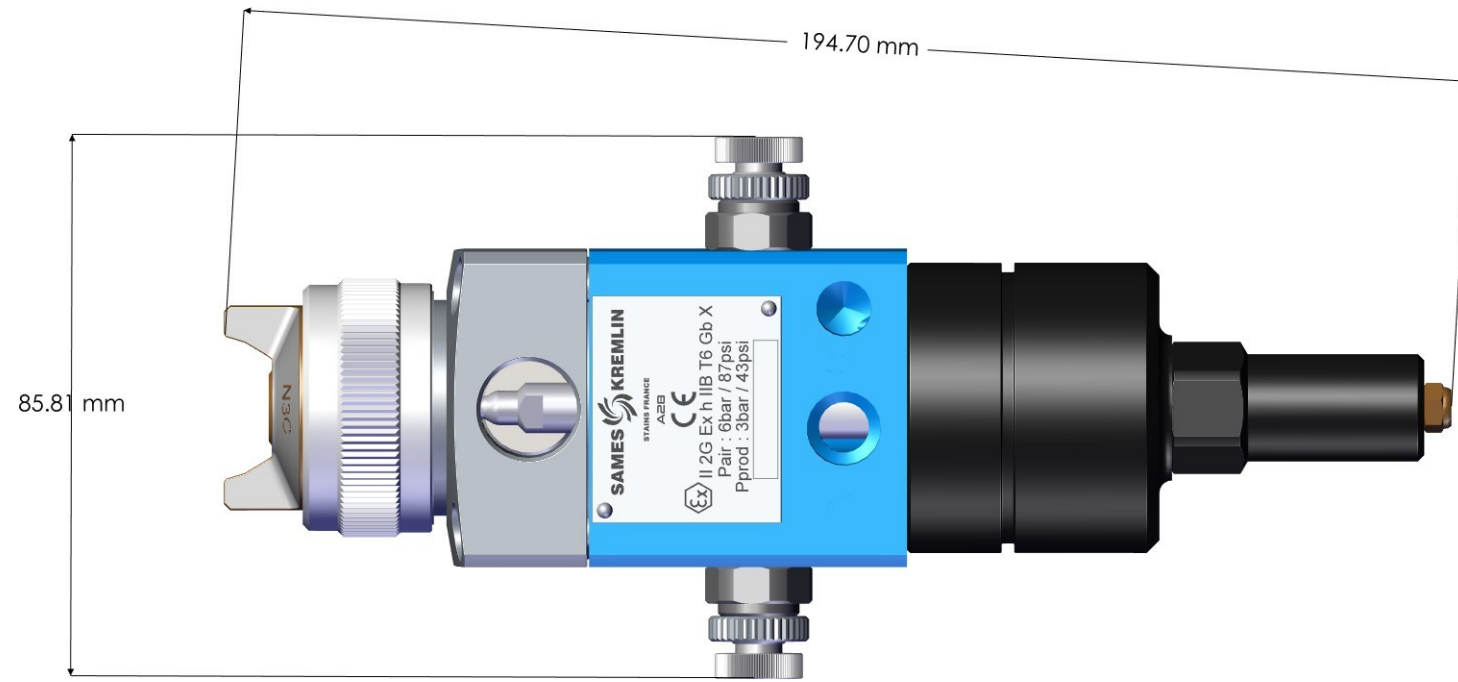

## 5 Equipment identification



### 5.1 Standards applied

ATEX Directive NF EN ISO 80079-36 June 2016 NF EN ISO 80079-37 June 2016 NF EN 1127-1 August 2019 Ex h=> Protection by constructional safety (c) INERIS 0080 - 60550 Verneuil-en-Halatte - France / no INERIS-CERN 036594/ 21	<b>2014/34/EU</b>
---	-------------------

### 5.2 Description of the ATEX

Each device is marked with the name of the manufacturer, the reference of the device and the important information for the use of the device (air pressure, electrical power...).

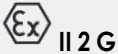
The equipment has a design as per ATEX Directive 2014/34/EU and are intended for use in Zone 1.

Description	
<b>Code SAMES KREMLIN</b>	Manufacturer's mark
<b>A28</b>	Model of the gun
<b>CE</b>	<b>CE</b> : European conformity
	 : Use in explosive areas <b>II</b> : Group II <b>2</b> : Category 2 surface equipment intended for use in an environment in which explosive atmospheres due to gases, vapours or mists are likely to occur occasionally during normal operation. <b>G</b> : gas
<b>Ex h IIB T6</b>	<b>Ex</b> Marking of conformity to European standards <b>h</b> :Type of protection for non-electrical equipment <b>IIB</b> :Reference gas for equipment qualification <b>T6</b> : Temperature class - Maximum surface temperature: 85°C
<b>Gb</b>	<b>Gb</b> : Equipment protection level (zone 1 gas)
<b>X</b>	Special conditions apply for safe use. Refer to the requirements in the instruction manuals accompanying this product.
<b>P air: 6 bar / 87 psi</b>	Maximum air supply pressure to the gun
<b>P prod: 6 bar / 87 psi</b>	Maximum fluid pressure at gun inlet
	Number given by SAMES KREMLIN. The first two digits indicate the year of manufacture.

5.3 Visuals of the marking elements

A28

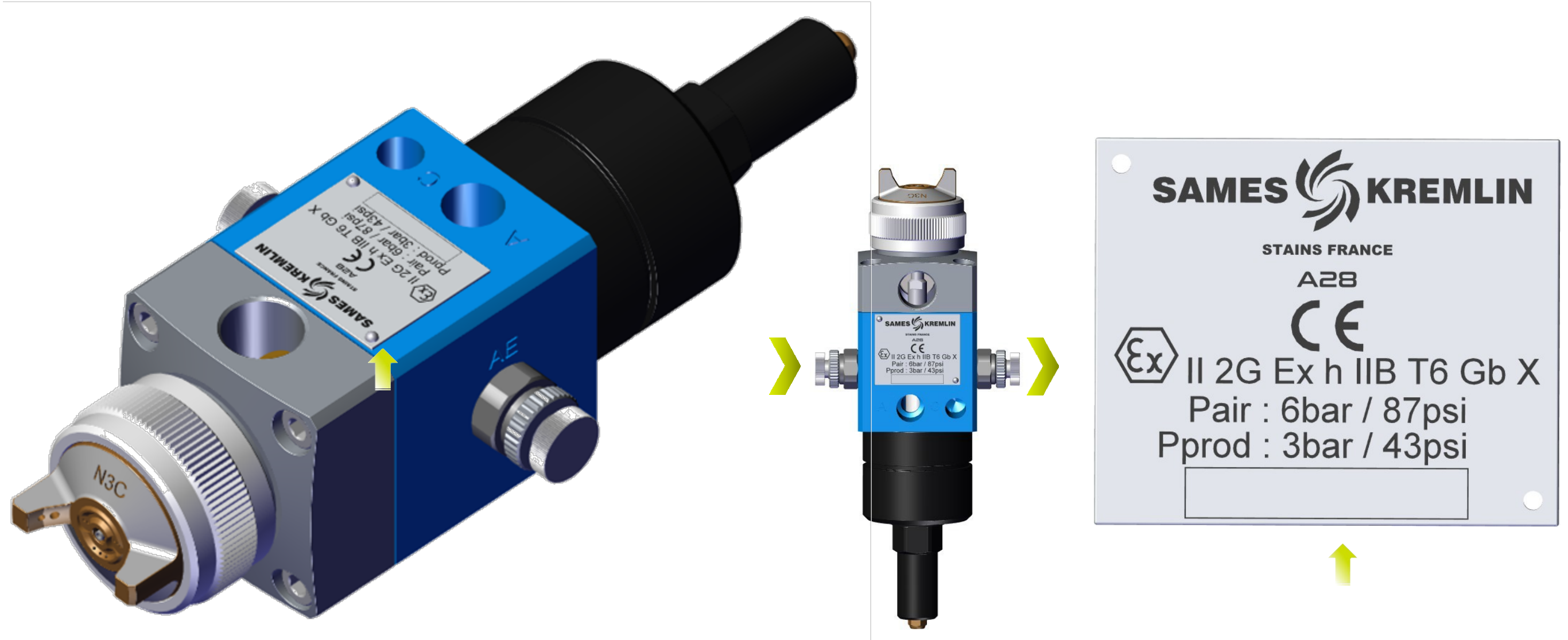

## 6 Technical specifications and performance

### 6.1 Technical specifications

A28

<b>Spray air pressure</b>	6 bar max
<b>Control air pressure</b>	5.5 bar minimum
<b>Product pressure</b>	3 bar max
<b>Product flowrate</b>	Next nozzle
<b>Air consumption</b>	24 m <sup>3</sup> /h at 4 bar
<b>Operating temperature</b>	50°C max
<b>Weight (without stand)</b>	1050 g
<b>Materials in contact with</b>	Stainless steel - Treated stainless steel - PTFE -Polyurethane elastomer

#### Connections

	<b>Pistol</b>	<b>Recommended hose</b>
Product	F 3/8 BSPF	Ø 10 mm inside
Control air	1/8 NPS F	Ø 6 x 8 mm
Spray air	1/4 NPS	Ø 10 mm inside
Air points	AE (air to vents) AC (air to center)	Spray width (flat jet, round jet) Spray fineness

The gun can be fitted with :

- or 2 product connections > product circulation
- or 1 fluid connection and a plug

Fixing of the set: rod Ø 16, length 160 mm.

---

## 7 Installation

### 7.1 General installation diagram

Attach the gun to the bracket. Connect the paint and air hoses.

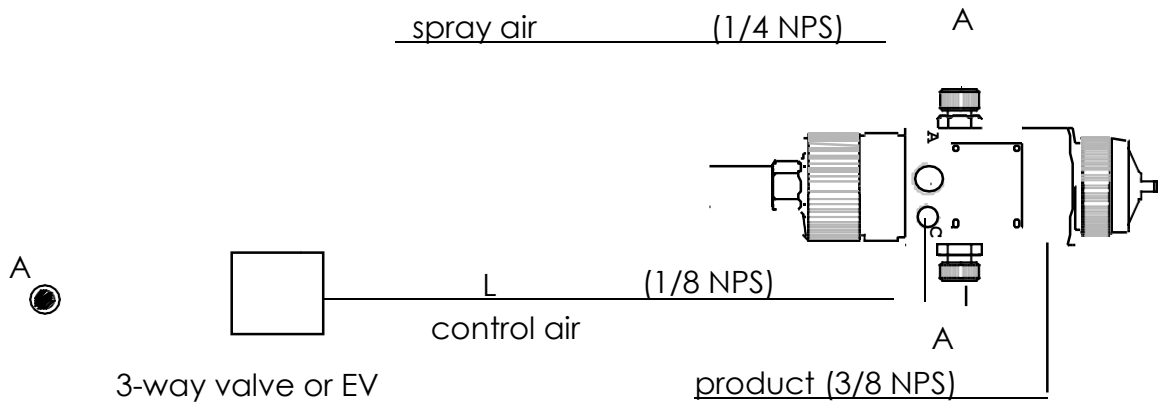

The A 28 gun is pneumatically operated. To operate it, it is connected to a solenoid valve or a 3-way pneumatic valve. The solenoid valve should be placed as close as possible to the gun ( $L \sim 2$  m).

If the installation requires a greater distance ( $L$ ) between the solenoid valve and the gun, or if the frequency of use is greater than 0.5 Hz, it may be preferable to replace the air hose for order  $\text{Ø}6 \times 8$  by an  $\text{Ø}8 \times 10$  pipe to reduce response times.

---

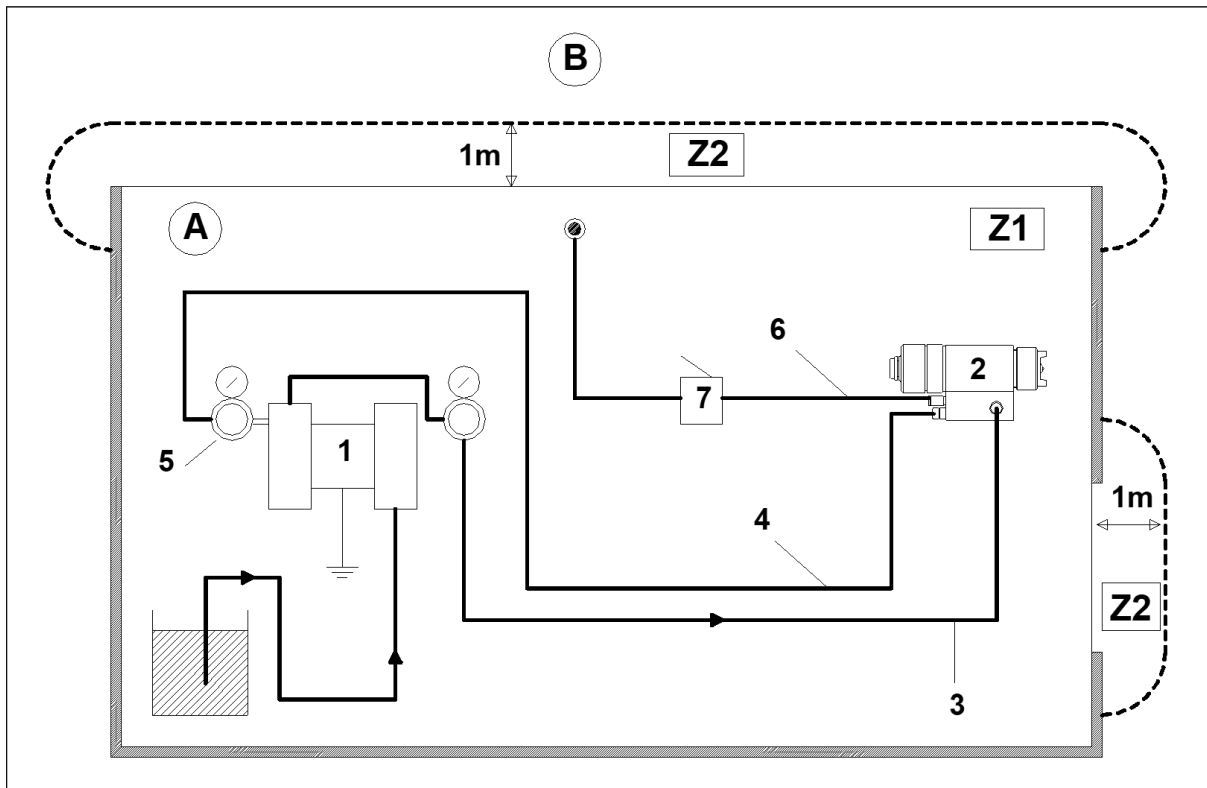

### Legends

A	Explosive zone zone 1 (Z1) or zone 2 (Z2): paint booth	3	Fluid hose
B	Non-explosive area	4	<b>Conductive</b> air hose (spray air)
		5	Air regulator
1	Pump	6	Air hose (control air)
2	Automatic pneumatic gun	7	3-way valve or solenoid valve

- 1 - Using a fluid hose (3), connect the gun's paint fitting to the pump. Tighten the fittings securely.
- 2 - Using a **conductive** air hose (4), connect the "Spray Air" connection on the gun (2) to an air regulator (5) capable of supplying at least 3 bar (spray air).
- 3 - Using an air hose (6), connect the "Control Air" fitting on the gun to the valve or solenoid valve (7) that will open and close the gun.

**A minimum pressure of 3 or 4 bar is required to operate the gun (control air).**



Note: If the fluid hose (3) is non-conductive, the air hose (4) must **must** be a driver.

**It is imperative that one of the 2 hoses (spray air or fluid) of the gun is conductive.**

---

## 8 Operation

Unscrew the fluid needle stop on the back of the gun. Unscrew the air needle(s) located on the base or on the gun.

Choose the projector (head + nozzle + needle) adapted to the work to be done.

Screw the nozzle, then the head onto the gun.

Before tightening the head ring, position the head to obtain the desired spray position. The spray is vertical when the 2 ears of the head are horizontal.

**It is recommended to put the gun in "OPEN" position to mount the nozzle without damaging the needle.**

---

## 9 Setting

The professional gun has 3 settings :

### **Air pressure**

Supply the gun with air from the network (clean air - pressure: 6 bar maximum).

Control the opening of the gun (air pressure > 3 bar).

Adjust the air pressure upstream of the gun to obtain a good spray.

### **The width of the jet**

It can be adjusted by turning the knurled knob on the vent needle. The air admitted to the side vents is controlled in this way to change from flat jet (wide open) to round jet (closed).

### **Paint flow**

It is regulated by the choice of the projector and the pressure of the product.

It is possible to further adjust the flow rate by adjusting the needle stroke (needle stop knob) in the case of fluid supply.

The optimum setting is achieved with the fluid needle fully open (an almost closed needle does not ensure a steady stream).

---



# 10 TIPS FOR USING THE GUN

When mounting the head on the gun, hold the gun vertically to position the head correctly before tightening the head ring.

Always position the gun perpendicular to the surface to be painted. Do not forget that cross passes do not make up for irregularities. Spraying with the gun stopped gives a local overload.

Make sure to obtain a good and regular overlapping of the different passes (gun moving vertically, pieces to be painted moving horizontally).

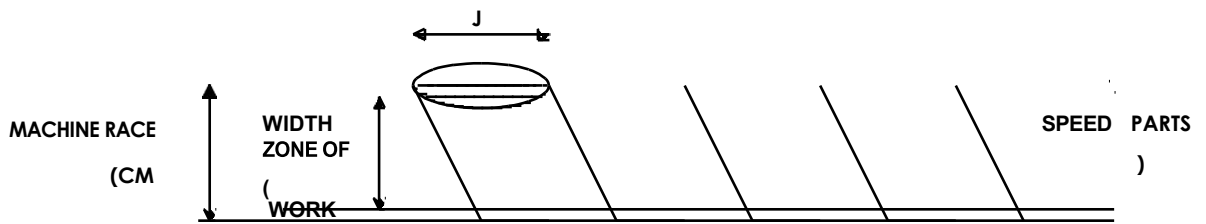

This width  $J/2$  for 2 regular coats of paint corresponds exactly to the following formula :

$$J/2 \text{ (m)} = VP \text{ (m/s)} \times 2 \frac{CM \text{ (m)}}{VM \text{ (m/s)}}$$

Formula in which :

- VP** = feed speed of the products to be painted.
- CM** = total stroke of the machine (thus of the guns).
- VM** = speed of the machine (and therefore of the
- 2** = 2 regular (4 if one wanted double the number of coats overlapping).

---

## Cleaning the gun

This gun is a precision tool. Its proper functioning requires frequent and careful maintenance. If it is done immediately after the work, cleaning is easier and faster.

**Never use wire brushes, files, or pliers for disassembly**

### Short stop (less than 3 hours)

Leave the material as it is. However, if exceptionally the head is a little covered with paint, it is prudent to clean it with a brush and solvent.

### Long term absence from work

Shut off the air and fluid supply to the gun.

Relieve the pressure on the hoses by pulling the trigger or opening the gun.

Unscrew the gun head, soak it in the solvent and brush it with a brush.

Using a wrench, unscrew the nozzle and remove the needle from the back of the gun. Soak the nozzle. Brush it. Using the solvent soaked brush, clean the inside of the gun. Wash and brush the threads of the screwed parts thoroughly.

**Never dip the gun into the solvent**

---

## 10.1 Transport

Put the product in its original packaging during transport.

The packaging of the gun corresponds to the transport conditions provided for this purpose.

The packaging protects :

- Damage related to transport.
  - Corrosion.
- 

## 10.2 Storage

Our equipment must be stored in its original packaging.

In the event of prolonged storage, it is advisable to carry out preventive maintenance on all lubricants before commissioning.

### **Storage before installation**

Ambient storage temperature 0 / +50 °C.

- Protect the unit from dust, water runoff, moisture, vibration and shock.
- Do not remove the packaging until just before assembly.





### **Storage after installation**

- Protect the unit from dust, water run-off, moisture and impact.
- 

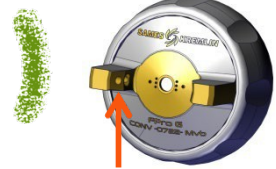

- Do not store more flammable products than necessary within the work area.
  - These products must be stored in approved, grounded containers.
  - Use only grounded metal buckets for flushing solvents. Cardboard and paper are to be banned. Indeed they
  - are very bad conductors, even insulators.
-

## 11 Diagnostic Help/Troubleshooting Guide

Subject	Explanatio	Visual
<p><b>Bean- shaped jet</b></p>	<p>The fault comes from the head: slightly loosen the ring and turn the head half a turn; if the fault is reversed, one of the side vents is blocked or deformed.</p> <p>Then clean the gun head with solvent and clear the vents with a jet of compressed air. If this does not reverse, the nozzle is probably damaged.</p>	
<p><b>Offset jet</b></p>	<p>This deformation is due to a defect in the central jet. The head and nozzle must be cleaned as described above. Also check that :</p> <ul style="list-style-type: none"> <li>• The head is well centered on the nozzle,</li> <li>• The nozzle is not too big (needle and nozzle must be adapted), you work with a sufficient opening of the needle.</li> <li>• With an almost closed needle, the paint jet is not supplied evenly in all directions.</li> </ul>	
<p><b>Jet cut</b></p>	<p>The pressure of the air jets at the vents is too high for the paint flow:</p> <ul style="list-style-type: none"> <li>• Reduce air to the vents by closing the control needle. The jet is less wide.</li> <li>• Increase product flow.</li> </ul>	
<p><b>Center-loaded jet</b></p>	<p>Inverse of the previous one:</p> <ul style="list-style-type: none"> <li>• Either the paint flow rate is excessive for the adopted spraying air pressure: you must increase the spraying air pressure and reduce the paint flow rate.</li> <li>• Either the paint is too thick: you must then thin it.</li> </ul>	
<p><b>Paint jet jerks</b></p>	<p>The gun is shooting. The phenomenon is caused by air entering the paint circuit:</p> <ul style="list-style-type: none"> <li>• The container containing the product may be empty: add paint.</li> <li>• The nozzle is not tight and does not sit well: tighten the nozzle.</li> </ul> <p>If the phenomenon persists, remove the nozzle and clean it.</p> <ul style="list-style-type: none"> <li>• Check that the nozzle seat and cone are not damaged, reassemble the nozzle and lock it.</li> <li>• Check that the paint is fluid and homogeneous enough to be vacuumed.</li> <li>• Check that the pressure gun is not used with a suction cup.</li> </ul>	

### 11.1 Possible symptoms of faults - Causes of faults – Remedies to apply

DEFAULT	ORIGIN	REMEDY
The paint no longer comes out of the gun	Clogged nozzle	Turn off the pressure on the pump. Remove and clean the nozzle. Decompress the hoses well.
The jet narrows at reversals	Air intake in the paint	Check that there are no air intakes in the suction pipe.
	Viscosity too high	Dilute the paint.
The head gets dirty frequently	Too much air	Reduce the air pressure.
	Fluid seal (or cartridge) leak	Replace the seal or cartridge.
The paint comes out of the air holes in the head	Defective nozzle seal	Replace it.
	Insufficiently tightened ring	Squeeze it.
Paint leakage	Impurities in paint	Open and close the gun control 3 or 4 times.
	Worn out needle	Replace the needle and nozzle.
	Worn cartridge or gasket	Replace it.

## 11.2 Dismantling and reassembly

### 11.2.1 Dismantle the A28

Benchmark reminder

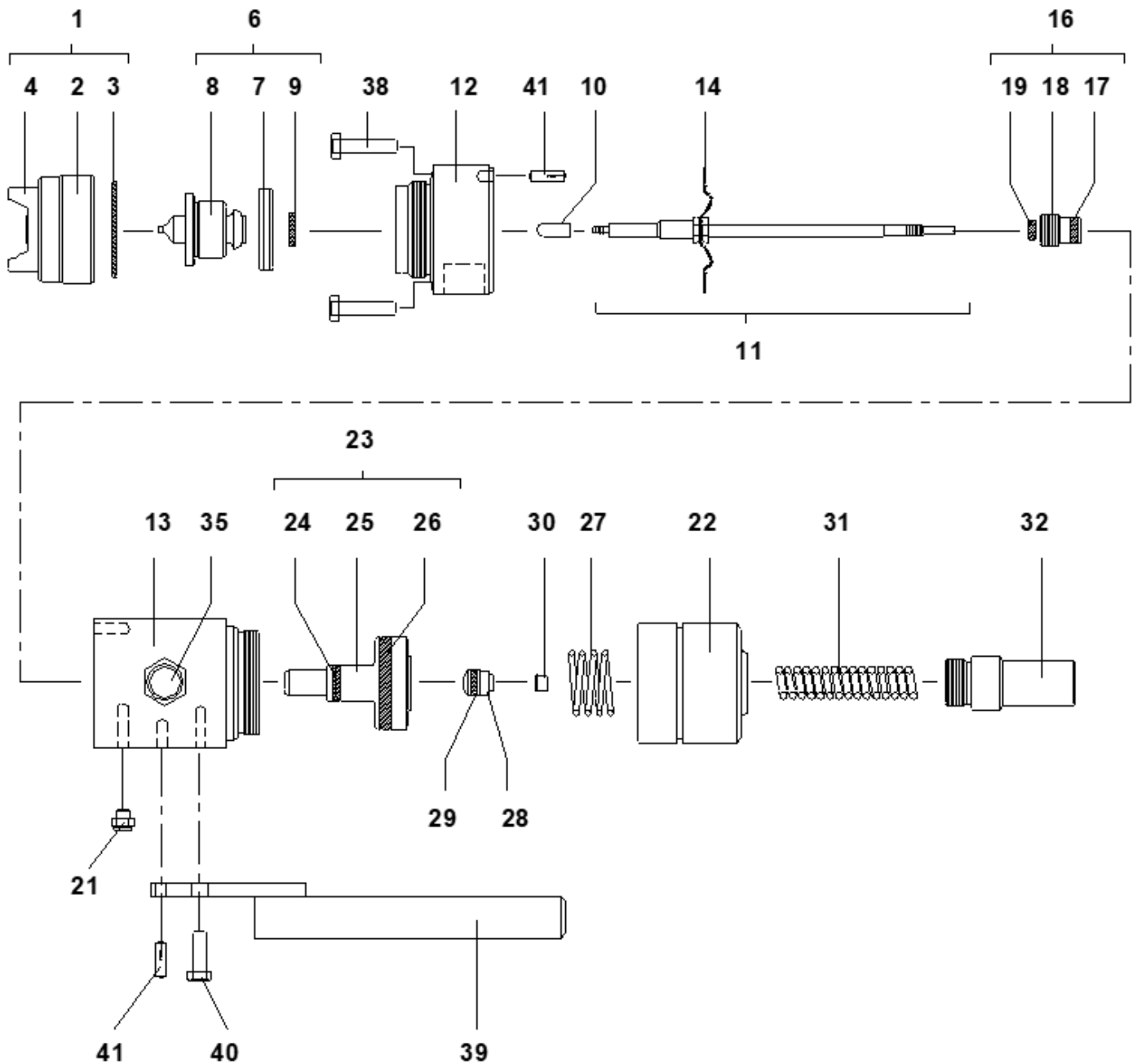

### 11.2.2 Replacing the needle tip (item 10)

- Shut off the air and fluid supplies to the gun.
- Relieve pressure from the circuits.
- Unscrew the head (item 1) and the nozzle (item 2) from the gun.
- Unclip the needle tip (item 10) from the needle holder (item 11).
- Clip on the new needle tip.
- Move the gun to the "OPEN" position to install the nozzle without damaging the new needle.

### 11.2.3 Replacing the diaphragm (item 14)

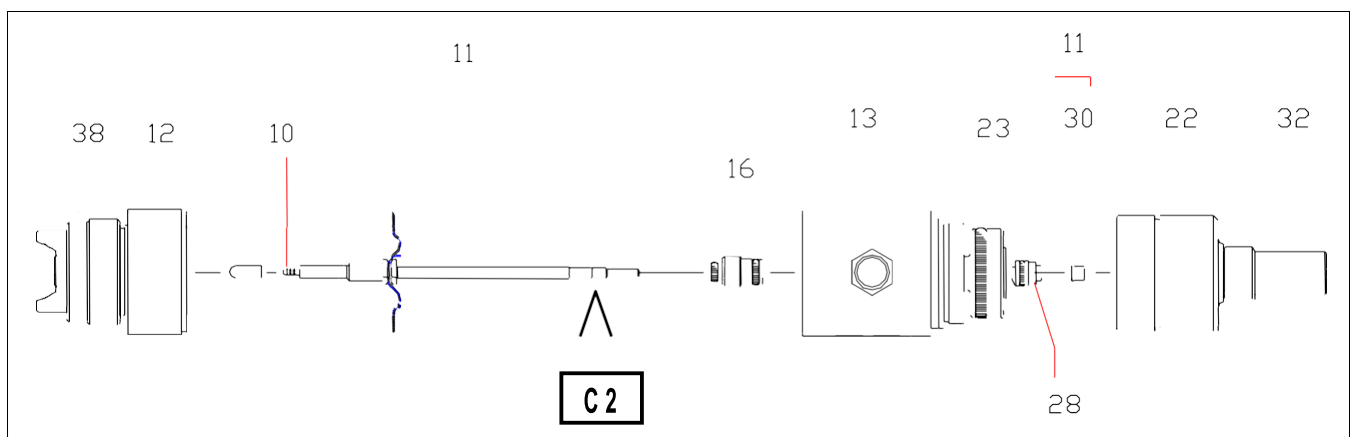

#### Disassembly

- Unscrew the head (item 1) and the nozzle (item 2) from the gun. Unscrew the 4 screws (item 38). Remove the fluid body (item 12). Unscrew the needle tip (item 10).
- Unscrew the cylinder (item 22) to separate it from the air body (item 13).
- Unscrew the nut (item 30).
- Pull the needle-diaphragm assembly (item 11) to the front of the gun.

**Reassembly**

- Take a new "Diaphragm assembly" (item 11). Unscrew the nut
  - (item 30) mounted on this assembly.
  - Put grease on the needle rod.
  - Insert the assembly (item 11) into the body (item 13) from the front of the gun.
  - Check the position of the piston (item 23) in the air cylinder (item 13).
  - Position the needle driver (item 28) correctly in the piston (item 23).
  - Apply low thread locking adhesive to the thread at the end of the needle (item C2).
  - Tighten the nut (item 30) moderately.
  - Reassemble all parts: needle tip, fluid body, nozzle, head, cylinder. Change them if necessary
  - **Caution: Fluid may leak from the nozzle when the gun is re-pressurized.**
-



11.2.4 Reminder of the greases and adhesives required for the assembly instructions

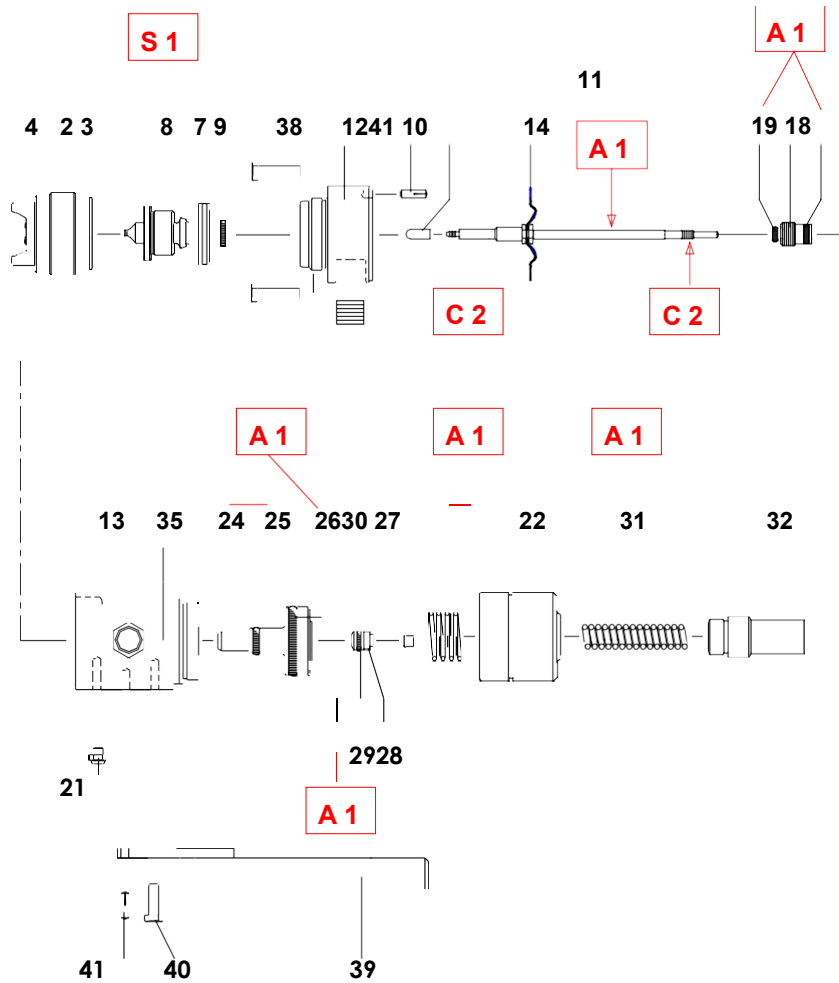

Marker	Instructions	Designation	Reference
<b>A1</b>	PTFE grease	Tube of "TECHNILUB" grease (10 ml)	560.440.101
<b>C2</b>	Anaerobic adhesive with low thread lock	Glue bottle (50 ml)	554.180.010
<b>S1</b>	tightening torque: 9 - 11 Nm		