



INSTRUCTION MANUAL

VOLUREX PROPORTIONING GUN

25 cc / 0.8 oz # 105 824 0406

50 cc / 1.7 oz # 105 435 0102

100 cc / 3.4 oz # 104 145 0102

Manual : 574.065.112 - 1703

Date : 21/03/17 - Supersede : 18/06/12

Modif.: Update

TRANSLATION FROM THE ORIGINAL MANUAL

IMPORTANT : before assembly and start-up, please read and clearly understand all documents relating to this equipment (professional use only).

PICTURES AND DRAWINGS ARE NON CONTRACTUAL. WE RESERVE THE RIGHT TO MAKE CHANGES WITHOUT PRIOR NOTICE.

SAMES KREMLIN SAS
13, chemin de Malacher
38 240 - MEYLAN - France
☎ : 33 (0)4 76 41 60 60

www.sames-kremlin.com



**INSTRUCTION MANUAL
VOLUREX PROPORTIONING GUN**

TABLE OF CONTENTS

01. WARRANTY	2
02. SAFETY INSTRUCTIONS.....	3
03. DESCRIPTION	6
04. OPERATING PRINCIPLE	7
05. TECHNICAL FEATURES.....	9
06. INSTALLATION	10
07. MAINTENANCE	10
08. TROUBLESHOOTINGS.....	11
09. DISASSEMBLY - ASSEMBLY.....	11
10. EXPLODED VIEW.....	12
11. SPARE PARTS' LIST.....	13

ADDITIONAL DOCUMENTATIONS :

<u>Spare parts</u>	Electric part	Doc. 574.042.110
	Movable mecanic part	Doc. 574.043.110
	Fixed mecanic part	Doc. 574.044.110
	Proportioning part	Doc. 574.045.110
	Inlet valve	Doc. 574.046.110
	Outlet valve	Doc. 574.066.110
	Pneumatic part	Doc. 573.047.110

Dear Customer,

You are the owner of our new equipment and we would like to take this opportunity to thank you.

To make sure your investment will provide full satisfaction, special care has been taken during all designing and manufacturing processes.

To obtain the best result, safe and efficient operation of your equipment, we advise you to read and make yourself familiar with instruction and service manual. Indeed, the non-compliance with instructions and precautions stated in this manual, could reduce the equipment working life, result in operating trouble and create unsafe conditions.

01. WARRANTY

We reserve the right to make changes; these changes may be carried out after the receipt of the order. No claim will be accepted as a consequence of any change carried out in the instruction manuals or in the selection guides.

Our equipment is checked and tested prior to shipment. In the case of a problem arising with the equipment, this must be in writing, within ten days from the delivery date.

SAMES KREMLIN warrants all equipment manufactured bearing its name, to be free from defect in material or workmanship for a period of 12 months (one shift per day or 1800 hours - 1 term reached) from the date of delivery. Work life is based on single shift working - 8 hours per day. Warranty claims for defective items will only be accepted in writing and will be verified and confirmed by us.

The warranty does not cover fair wear and tear, damage or wear caused by misuse, improper maintenance or non-observance of our recommendations.

SAMES KREMLIN will repair or replace parts (carriage paid to our plant and accepted as defective by us). We shall not be liable for any losses, resulting from a production breakdown. Upon request, we can carry out service work at your premises; all expenses (travelling and accommodation) for KREMLIN REXSON technicians will be chargeable.

In the event that it is found that equipment has been tampered with, this will invalidate the warranty. Equipment that it is bought in will be subject to the suppliers' warranty.

02. SAFETY INSTRUCTIONS

GENERAL SAFETY INSTRUCTIONS



CAUTION : The equipment can be dangerous if you do not use it according to the rules mentioned in this instruction manual. Read carefully all the instructions hereafter before operating your equipment.

Only trained operators can use the equipment.

The foreman must ensure that the operator has perfectly taken in the safety instructions of this equipment as well as the instructions in the manuals of the different parts and accessories.

Read carefully all instruction manuals, label markings before operating the equipment.

Incorrect use may result in injury. This equipment is for professional use only. It must be used only for what it has been designed for.

**Guards (air motor cover, coupling shields, housings,...) have been designed for a safe use of the equipment.
The manufacturer will not be held responsible for bodily injury or failure and / or damage to property due to removal or partial removal of the guards.**

Never modify the equipment. The parts and accessories supplied must be regularly inspected. Defective or worn parts must be replaced.

Never exceed the equipment components' maximum working pressure.

Comply with regulations concerning safety, fire risks, electricity in force in the country of final destination of the material. Use only products or solvent compatible with the parts in contact with the material (refer to data sheet of the material manufacturer).

PICTOGRAMS

A	D	F	E	C	G
NIP HAZARD	WARNING MOVING ELEVATOR	WARNING MOVING PARTS	WARNING MOVING SHOVEL	DO NOT EXCEED THIS PRESSURE	HIGH PRESSURE HAZARD
H	J	I	K	M	O
RELIEF OR DRAIN VALVE	WARNING HOSE UNDER PRESSURE	WEAR GLASSES OBLIGATORY	WEAR OF GLOVES IS OBLIGATORY	PRODUCT VAPOR HAZARDS	WARNING HOT PARTS OR AREAS
N	P	R	Q	S	T
ELECTRICAL HAZARD	WARNING FIRE HAZARDS	EXPLOSION HAZARDS	GROUNDING	WARNING (USER)	WARNING SERIOUS INJURIES

PRESSURE HAZARDS



Current legislation requires that an **air relief** shut off valve is mounted on the supply circuit of the pump motor to let air off when closing the supply circuit. Without this precaution, the motor residual air of the motor may let the pump beat and cause a serious injury.

Please ensure that, a **material drain valve** is mounted on the material circuit to drain it (after shutting down air to the motor and the pressure relief) before any servicing on the equipment. These valves must be closed for air and opened for product when processing.

HIGH PRESSURE INJECTION HAZARDS

When working with high pressure equipment, special care is required. Fluid leaks can occur. Then there are injection risks in exposed parts of body that may cause severe injuries or amputations :



- Medical care must be handled immediately if product is injected under the skin or in other parts of the body (eyes, fingers).
- Never point the spray gun at any one. Never try to stop the spray with your hands or fingers nor with rags or similars.
- **Follow the shut down procedure and always depressurize air and fluid circuits** before carrying out any servicing on the gun (cleaning, checking, maintenance of the material or cleaning of the gun nozzles).
- For the guns equipped with a safety device, always lock the trigger when you do not start the gun.

FIRE - EXPLOSION - SPARKS - STATIC ELECTRICITY HAZARDS



A poor earth connection, inadequate ventilation, sparks or static electricity can cause an explosion or fire. to avoid these risks when using or servicing SAMES KREMLIN equipment, the following safety procedures must be followed :



- ensure a good earth connection and ground the parts to be handled i.e. solvents, materials, components and equipment,
- ensure adequate ventilation,
- keep working area clean and free from waste solvents, chemicals, or solid waste i.e. rags, paper and empty chemicals drums,
- never use electrical switches / power if in an atmosphere of volatile solvent vapour,
- stop working immediately in case of electrical arcs,
- never store chemicals and solvents in the working area.

TOXIC PRODUCT HAZARDS

Toxic products or vapours can cause severe injury not only though contact with the body, but also if the products are ingested or inhaled. It is imperative :



- to know the material products and their risks,
- notified or hazardous materials must be stored in accordance with the regulations,
- the material must be stored in an appropriate container, never place materials in a container where there is a risk o spillage or leakage,
- a procedure must be applied for the safe disposal of waste material. It must comply with all prevailing regulations and legislations of the country where the equipment is to be used,
- protective clothing should always be worn in compliance with the material manufacturers' recommendations,
- depending on the application and chemical safety instructions, safety glasses, hearing protective earplug, gloves, foot wear, protective masks and possible breathing equipment should be worn to comply with the regulations

(Refer to chapter "Safety equipment of SAMES KREMLIN selection guide).



CAUTION!

It is forbidden using any solvent or with halogenated hydrocarbon base and also products with these solvents facing **aluminium** or **zinc**. The non-compliance with the instructions may cause explosion hazards causing serious or fatal injuries.

EQUIPMENT REQUIREMENTS

Guards (air motor cover, coupling shields, housings,...) have been designed for a safe use of the equipment.
The manufacturer will not be held responsible for bodily injury or failure and / or damage to property due to removal or partial removal of the guards.

PUMP

Before carrying out any work, it is imperative to get used with the compatibilities of motors with pumps before coupling. The operator shall understand the equipment and the safety instructions. These instructions are available in the manuals of the pumps.

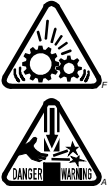

The air motor is designed to be mounted with a pump. Never modify any components or couplings. Where operating, please keep hands away from moving parts. Before starting up the equipment, please read the PRESSURE RELIEF instructions. Please ensure that any relief or drain valves fitted are in good working order.

HOSES

- Keep hoses out of circulation areas, moving parts or hot surfaces,
- Never expose product hoses to temperature higher than + 60°C / 140° F or lower than 0°C / 32° F,
- Never pull or use the hoses to move the equipment,
- Tighten all fittings as well as the hoses before operating the equipment,
- Check the hoses regularly; change them if they are damaged,
- Never exceed the maximum working pressure (MWP) indicated on the hose.

USED PRODUCTS

Considering the variety of products that may be used by the users and the impossibility to check off all chemical data, of possible reactions of chemicals to each other and their long term evolution, SAMES KREMLIN can not be considered as liable for :

- the bad compatibility of wetted parts,
- risks for staff and surroundings,
- for worn or out of order parts, for wrong working of equipments or units, as well as for the qualities of final product.

The user must know and prevent the possible risks as toxic vapours, fires or explosions due to used products. He shall determine the risks of immediate reactions or pursuant to repeated exposures of the staff.

SAMES KREMLIN shall not be liable for psychic injuries, direct or indirect material damages further to the use of chemicals.

ENVIRONMENT

Label marking on the Volurex proportioning system

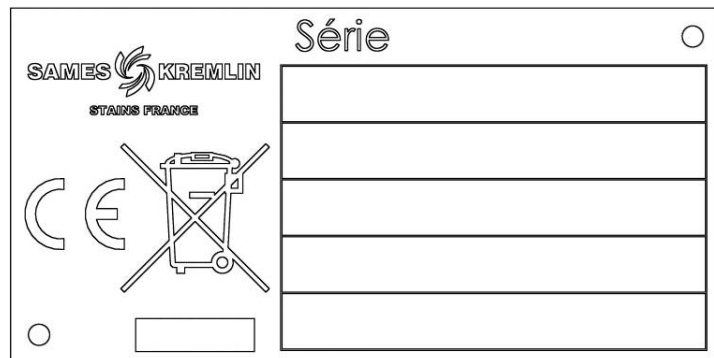

This equipment consists of a label plate with the name of the manufacturer, the equipment part number, the interesting informations to use correctly the equipment (pressure, voltage...) and the above pictogram.

The equipment is designed with and consists of high quality materials and components which can be re-used.

The 2012/19/UE European Directive covers all equipments with a crossed-out bin pictogram. Please inform yourself about the collection systems for electric and electronic equipments.

Please according to local rules and **do not throw the old equipments with household wastes**. A correct disposal of the old equipment will help prevent negative consequences for the environment and health.

03. DESCRIPTION

The VOLUREX system consists of a Volurex proportioning gun and a control bay. It is designed for dispensing materials beads (silicone, adhesive, mastic...) for cold and hot extrusion.

The VOLUREX assembly is linked to a robot that ensures the displacement of the proportioning system (or of the part). The robot sends a signal to the control bay, thus providing the flow rate required to dispense the bead.

The flow rate as well as the dosing are programmable and electronically controlled thanks to the control bay.

Depending upon the external informations (robot, manipulator, proportioning system), the bay drives the system. It controls some safety devices that protect the proportioning system and its environment.

04. OPERATING PRINCIPLE

The proportioning system consists of :

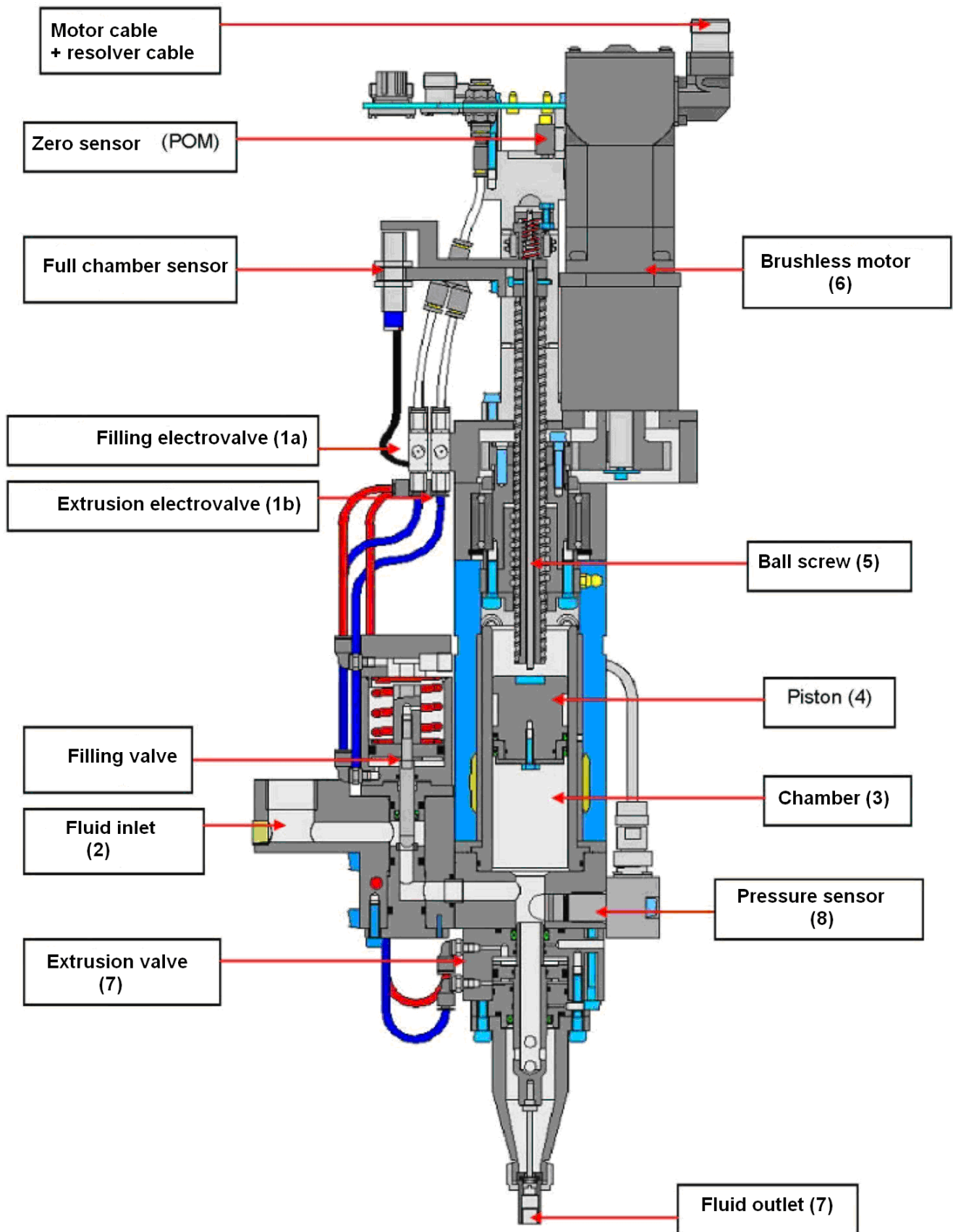

The dispensing system consists of 3 actuators :

- The motor (6) of the proportioning system gives a translation motion to the piston (4) via the ball screw (5)
- The electrovalve (1a) enables the material coming from the fluid inlet (2) to enter into the chamber.
- The electrovalve (1b) enables the material from the chamber (3) to be extruded via the fluid outlet (7).

▪OPERATING

First position :

- *The piston (4) is downwards and the ball screw (5) upwards.*

Filling :

- *The filling electrovalve (1a) opens to let the material enter in via the fluid inlet (2).*
- *The fluid enters in the chamber (3) via the shutting group (not represented).*
- *The piston (4) goes up because of the fluid until coming into contact with the ball screw (5).*

Pressurization :

- *Thanks to the pressure sensor (8), the piston (4) goes down to put the fluid to the required pressure.*

Extrusion :

- *The extrusion electrovalve (1b) opens to let the material enter in via the fluid outlet (7).*
- *The piston (4) goes down in the chamber (3) with a speed that fits in with the output selected by the robot.*
- *The volume applicated is calculated thanks to the stroke carried out by the piston (4).*

Drain :

The drain consists in :

- *carry out an extrusion (empty the gun chamber) during a long duration shutdown of the proportioning system or during a request of the operator.*
- *then carry out a filling operation (fill the gun chamber with material).*

05. TECHNICAL FEATURES

▀ DIMENSIONS

	A	B	C	D	E	F	G	H	I
mm	181	597	60	82	12	∅ 8	224	207	50
"	7.1	23.5	2.4	3.2	0.5	5/16	8.8	8.1	2
	J	K	L	M	N	O	P	Q	R
mm	10	52	110	120	181	67	40	187	142
"	0.4	2.05	4.3	4.7	7.1	2.6	1.6	7.4	5.6
	S								
mm	154								
"	6.1								

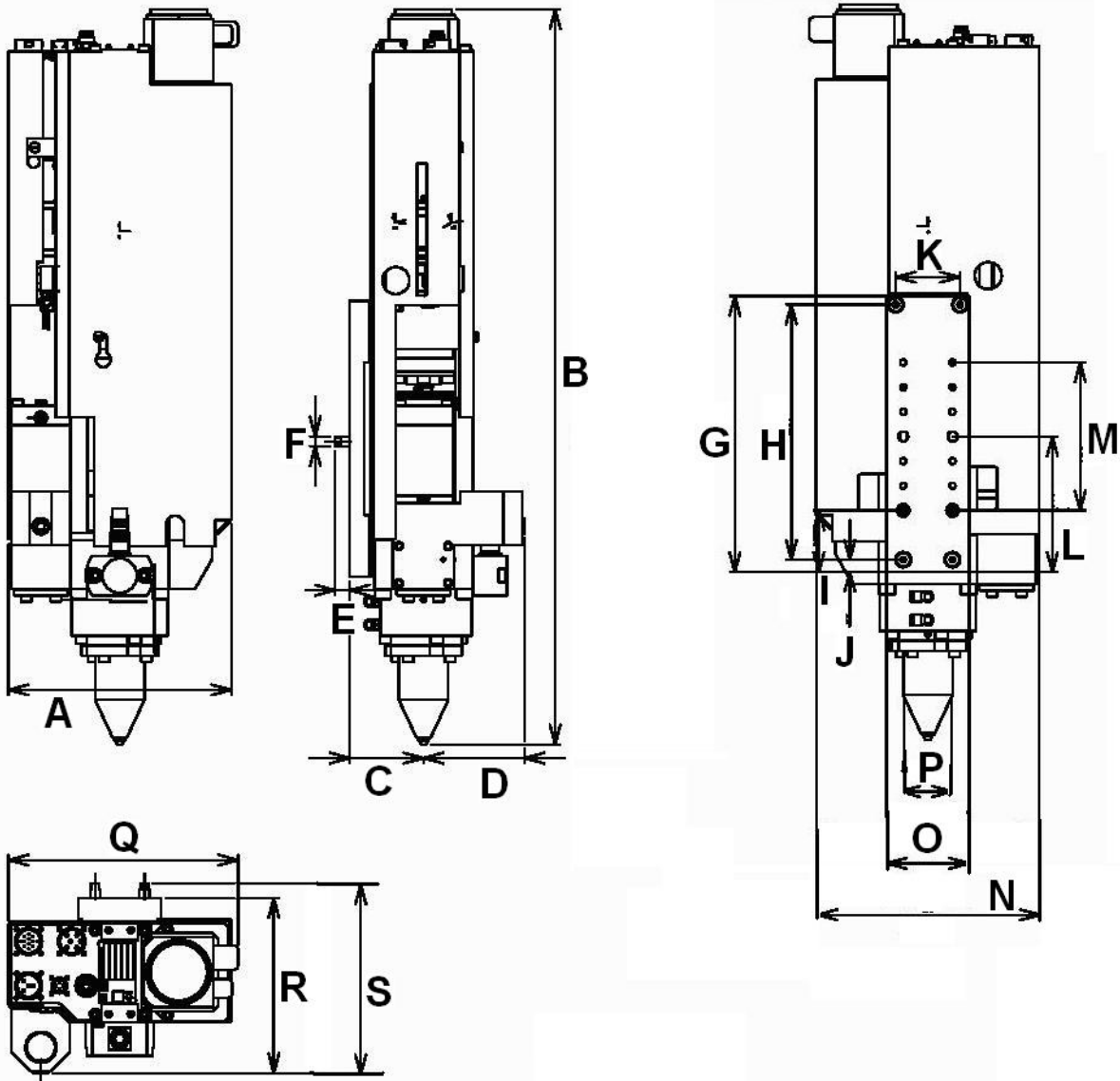

06. INSTALLATION

▪PNEUMATIC CONNECTIONS

Install a HP fluid hose between the mastic regulator fluid inlet and the VOLUREX proportioning system inlet valve. The hose can be heated one to make easier the fluid flow.

Install an air hose (Ø 4x6) to supply with compressed air the proportioning system. Connect it to the compressed air network by means of a regulator.

▪ELECTRIC CONNECTIONS

Connect the electric cables between the control bay and the proportioning system.

Connect the interface electric cables between the control bay and the robot control box.

Connect the control bay to the network.

07. MAINTENANCE

**Guards (air motor cover, coupling shields, housings,...) have been designed for a safe use of the equipment.
The manufacturer will not be held responsible for bodily injury or failure and / or damage to property due to removal or partial removal of the guards.**

▪DAILY PREVENTIVE MAINTENANCE

Be certain the hoses are in good condition and that there is no leakage.

Drain the proportioning gun after a long duration shutdown.

Clean the nozzle or change it (clogging or bead fault).

▪MONTHLY PREVENTIVE MAINTENANCE

Check the parameters of the bay (refer to bay instruction manual).

Check the friction ring wearing.



Lubricate the ball screw (every 300 hours)
(KLUBER grease - STABUTHERM GH 461)
(ball screw life duration: 500 000 cycles)

NEVER TAKE OFF THE BALL SCREW FROM THE NUT

▪BIMONTHLY PREVENTIVE MAINTENANCE

Remove the different components of the proportioning system :

- Clean the inlet and outlet valves, the proportioning part.
- Change the seals and the defective parts.
- Check the piston.
- Reinstall the seals, then lubricate them.
- Lubricate the ball screw from the lubrication device.

▪YEARLY PREVENTIVE MAINTENANCE

Remove and change the seals of the inlet valve.

Remove and change the seals of the outlet valve.

Remove and change the seals of the proportioning part.

Check the ball screw. Lubricate it.

08. TROUBLESHOOTINGS

If a trouble occurs during the operating of the VOLUREX proportioning system, the fault will be displayed on the bay display unit (refer to bay instruction manual).

09. DISASSEMBLY - ASSEMBLY

**Guards (air motor cover, coupling shields, housings,...) have been designed for a safe use of the equipment.
The manufacturer will not be held responsible for bodily injury or failure and / or damage to property due to removal or partial removal of the guards.**

Before removing the VOLUREX proportioning gun :

- Shut off the air supply of the pump,
- Drain the proportioning system,
- Open the pump drain valve,
- Shut off the proportioning system at the bay level,
- Disconnect all the beads of the electric connection,
- Remove the VOLUREX proportioning gun.

10. EXPLODED VIEW

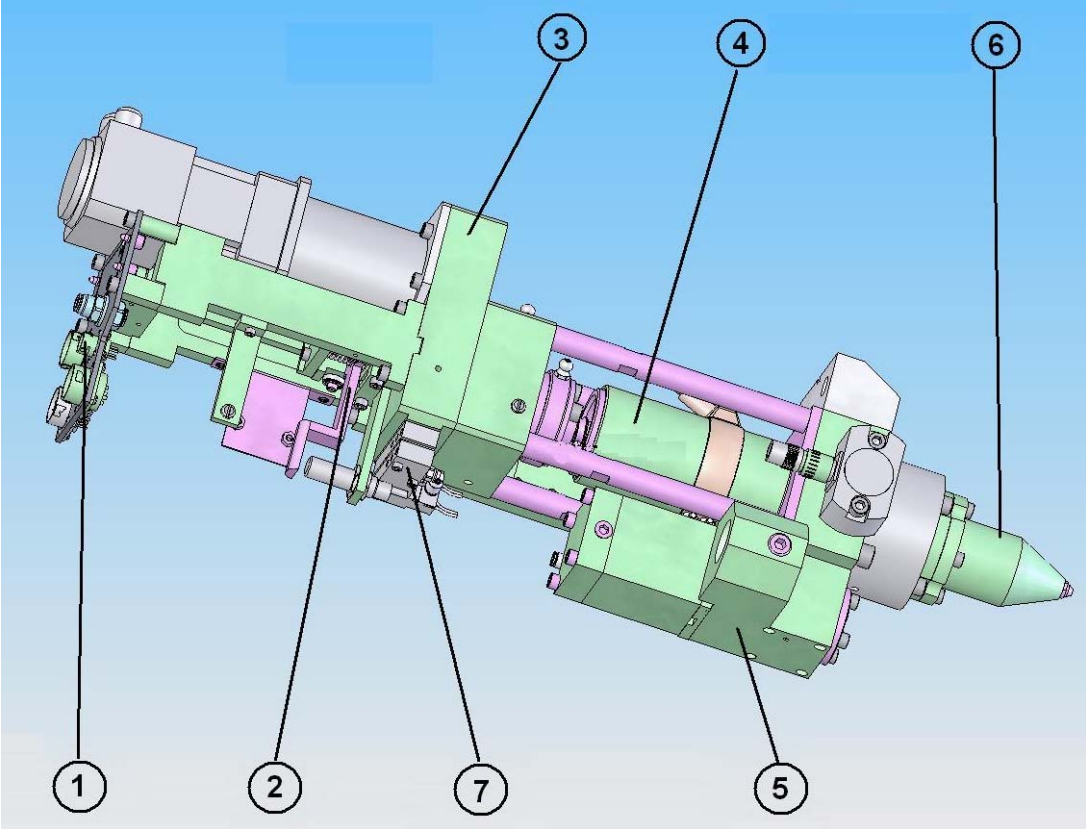

11. SPARE PARTS' LIST

VOLUREX PROPORTIONING SYSTEM	25	50	100
#	105 824 0102	105 435 0102	105 145 0102

Ind	#	Désignation	Description	Bezeichnung	Denominación	Qté
1	105 389	Partie électrique	Electric part	Elektrisches Teil	Parte eléctrica	1
2	105 806	Partie mécanique mobile	Movable mechanical part	Bewegliches mechanische Teil	Parte mecánica móvil	1
3	105 804	Partie mécanique fixe	Fixed mechanical part	Befestigtes mechanische Teil	Parte mecánica fija	1
*4	-	Partie dosage (voir pièces spécifiques)	Proportioning part (see specific parts)	Dosierungsteil (Siehe spezifische Teile)	Parte dosificación (consultar partes específicas)	1
*5	104 056	Vanne d'entrée	Inlet valve	Eingangsventil	Válvula de entrada	1
*6	104 202	Vanne de sortie	Outlet valve	Ausgangsventil	Válvula de salida	1
7	104 159	Partie pneumatique	Pneumatic part	Pneumatisches Teil	Parte neumática	1

Pièces spécifiques - Specific parts - Spezifische Teile - Partes específicas

Partie dosage / Proportioning part / Dosierungsteil / Parte dosificación			
Ind	Volurex 25	Volurex 50	Volurex 100
*4	# 104 471	# 104 357	# 104 198

**Voir les documentations séparées / See separated documentations
/ Siehe die zusätzlichen Bedienungsanleitungen / Ver las documentaciones separadas**

- * Pièces de maintenance préconisées.
- * Preceding the index number denotes a suggested spare part.
- * Bezeichnete Teile sind empfohlene Ersatzteile.
- * Piezas de mantenimiento preventivas.