



2 BALL PUMP

225 cm³

Pump REX 2B0225

User Manual 582131110

2024-03-18

Index C

Translation of the original instructions

SAMES KREMLIN SAS



13 Chemin de Malacher
38240 Meylan



www.sames-kremlin.com



33 (0)4 76 41 60 60

Any communication or reproduction of this document, in any form whatsoever, and any exploitation or communication of its contents are prohibited, except with the express written consent of **SAMES KREMLIN**. The descriptions and features contained in this document are subject to change without notice.
© **SAMES KREMLIN** 2021

Contents

Evolution table of the document	5
Additional Documentations	5
Guarantee	6
1 DECLARATION OF CONFORMITY	7
2 SAFETY INSTRUCTIONS	8
2.1 PERSONAL SAFETY.....	8
Overview.....	8
Meaning of the pictograms.....	9
Security devices	10
Danger of pressure	10
Injection hazards.....	11
Fire hazards, explosion, electric arc, static electricity.....	11
Hazards of toxic products	12
2.2 INTEGRITY OF THE MATERIAL	13
Material recommendations	13
Pump.....	13
Tubing	13
Products implemented	14
3 ENVIRONMENT	15
4 AVAILABLE CONFIGURATIONS	17
4.1 REXSON PARTS NUMBER OF HIGH VISCOSITY PUMPS	17
4.2 TABLE 1 FLUID SECTION-AIR MOTOR SELECTION	18
4.3 TABLE 2 FLUID SECTION – PUMP FOOT & MATERIAL SELECTION	18
4.4 TABLE 3 SEALS PACKS SELECTION	19
5 IDENTIFICATION.....	20
5.1 DESCRIPTION OF THE MARKING OF THE PLATE.....	20
5.2 CORRESPONDENCE TABLE NEW PART NUMBER / SIGNIFICANT DESIGNATIONS	22
5.3 CORRESPONDENCE TABLE EXISTANT PART NUMBER / SIGNIFICANT DESIGNATIONS	23
6 TECHNICAL CHARACTERISTICS AND PERFORMANCE	24
6.1 GENERAL CHARACTERISTICS	24
6.2 PRINCIPLE OF OPERATION	26
Expected use.....	26
Functional description	26
7 INSTALLATION	28
7.1 HANDLING	28
7.2 CONNECTIONS SUBSETS	28
7.2.1 FLUID SUPPLY CONNECTION	28
7.2.2 AIR SUPPLY CONNECTION	29
7.3 STORAGE	29
8 COMMISSIONING.....	30
Pump.....	30
Motor.....	30

9	USE OF THE PRODUCT	31
9.1	USER SETTINGS	31
	Wet Cup	31
	Tightening of the Wet Cup.....	31
	Tightening procedure	31
	Suction Valve Pin Adjustment.....	32
9.2	SAFETY IN PRODUCTION	33
9.3	START UP	33
9.4	SHUTDOWN PROCEDURE	34
	Pump.....	34
9.5	DIAGNOSTIC HELP / TROUBLESHOOTING GUIDE	35
	Possible symptoms of faults / Causes of faults / Remedies to apply.....	35
10	MAINTENANCE	37
10.1	PREVENTIVE MAINTENANCE PLAN	38
	Fluid section.....	38
10.2	GENERAL PRECONISATION MAINTENANCE.....	39
11	DISASSEMBLY / REASSEMBLY OPERATION.....	40
	Greases and thread lockers designations	40
	Disassembly of the pump.....	43
	Lower valve.....	43
	Wet cup seals.....	43
	Piston head	43
	Reassembly of the fluid section :	44
12	SPARE PARTS	45
	Lower adapter flange	48
	Repair Kit	49
	Recommended Seals pack	49
	Accessory	49
	Seals pack composition: 01 to 03.....	50
	Seals pack composition: 04 to 06.....	51
	Seals pack composition: 07.....	52

Evolution table of the document

Recording revisions				
Editor	Object	Revision	Date	Modified by
SEGUIN	2 Ball fluid section 225 cm ³ REX2B0225	A	03/03/2020	
SEGUIN	2 Ball fluid section 225 cm ³ REXSON 2B225	B	04/01/2021	
SEGUIN	2 Ball fluid section 225 cm ³ REXSON 2B225	C	18/03/2024	

Dear customer, you have just purchased your new equipment and we thank you for it.

We have taken the utmost care, from design to manufacture, so that this equipment gives you complete satisfaction.

For a good use and an optimal availability, we invite you to read this manual carefully before using your equipment.

Additional Documentations

	Documentation Reference
Air Motor 1000	582142110
Air Motor 1500	582141110
Air Motor 3000	582140110
Air Motor 5000	582146110

IMPORTANT: Before assembly and start-up, please read and clearly understand all the documents relating to this equipment (professional use only).

Guarantee

We reserve the right to make any changes or improvements even after receipt of an order without being able to attribute a non-compliance to the descriptions contained in the instruction manuals and selection guides.

Our equipment is checked and tested in our workshops before shipment.

To be valid, any complaint concerning a material will have to be formulated to us in writing within 10 days of the delivery.

SAMES KREMLIN equipment, equipped with its original identification plates, has a one-year warranty or 1800H of operation (in the first term reaches) from the date of ex-factory against any defect of material or defect of it is up to us to see and appreciate.

The warranty excludes wear parts, deterioration or wear resulting from abnormal or unscheduled use by SAMES KREMLIN, failure to observe instructions for proper operation or lack of maintenance.

The warranty is limited to the repair or exchange of parts returned to our factory and recognized as defective by us and does not cover the listed wear parts.

Any costs resulting from the operation cannot be charged to us. The costs of return to our workshops are the responsibility of the customer.

An intervention can be carried out on site at the customer's request.

In this case, the transportation and accommodation costs of the technician (s) will remain the responsibility of the applicant.

Any changes made to our equipment without our consent will void the warranty.

Our guarantee is limited to that of the suppliers of materials which enter in the composition of our sets.

1 Declaration of Conformity



Refer to the existing declaration delivered with the product.

2 Safety instructions

2.1 Personal safety

Overview



Read all operating instructions and device labels carefully before putting the equipment into service.

Personnel using this equipment must have been trained in its use.

The workshop manager must ensure that the operators have fully understood all the instructions and safety rules of this equipment and other elements and accessories of the installation.

Misuse or operation can cause serious injury. This material is for professional use only. It must be used only for the purpose for which it was intended.

Do not modify or transform the material. Parts and accessories must only be supplied or approved by SAMES KREMLIN.

The equipment must be checked periodically. Defective or worn parts must be replaced.

Never exceed the maximum working pressures of the equipment components.

Always respect the laws in force regarding security, fire, electricity of the destination country of the equipment.

Only use products or solvents that are compatible with the parts in contact with the product (see product manufacturer's technical data sheet).

Meaning of the pictograms

 <p>Danger: pinching, crushin</p>	 <p>Danger: moving parts</p>	 <p>Danger: high pressure</p>	 <p>Risks of product emanation</p>
 <p>Danger: hot parts or surfaces</p>	 <p>Danger: flammability risks</p>	 <p>Danger: electricity</p>	 <p>Risk of explosion</p>
 <p>Danger (user)</p>	 <p>Warning Danger</p>	 <p>Gloves required</p>	 <p>Grounding</p>
 <p>Protective helmet</p>	 <p>Hearing protection</p>	 <p>Mandatory respiratory protection</p>	 <p>Safety shoes</p>
 <p>Protective clothing</p>	 <p>Protective visor</p>	 <p>Safety glasses is mandatory</p>	 <p>Refer to the manual/instruction leaflet</p>

Security devices



Attention

- ✓ Guards (motor cover, coupling guard, housings, ...) are set up for safe use of the equipment.
- ✓ The manufacturer cannot be held responsible for any bodily injury as well as failures and / or damage to the equipment resulting from the destruction, the occultation or the total or partial removal of the protectors.
- ✓ Never exceed the maximum working pressures of the equipment components.

Danger of pressure



Safety requires that a pressure relieve shutoff valve be mounted on the pump motor supply circuit to allow trapped air to escape when the supply is shut off.

Without this precaution, the residual air from the engine may cause the motor pump to operate and cause a serious accident.

Similarly, a **material bleed valve** must be installed on the material circuit so that material pressure can be relieved (after shutting off air motor and decompressing it) before any intervention on the equipment. These valves should remain closed for air and open for the material during the procedure.

Injection hazards



"HIGH PRESSURE" technology requires the utmost care.

Operation can cause dangerous leaks. There is a risk of product injection into exposed parts of the body, which can lead to serious injury and the risk of amputation:

- ✓ An injection of product into the skin or other parts of the body (eyes, fingers ...) must be treated urgently by appropriate medical care.
- ✓ Do not look at the gun nozzle when it is under pressure.
- ✓ Never point the gun nozzle at another person.
- ✓ Never attempt to stop the jet with the body (hands, fingers ...) or with rags or similar.

Fire hazards, explosion, electric arc, static electricity



Improper grounding, insufficient ventilation, open flames or sparks can cause an explosion or fire which could result in serious injury.

To avoid these risks, especially when using pumps, it is imperative:

- ✓ Before operating the Pump supply system make sure that all Pump equipment and material containers are grounded,
- ✓ To ensure good ventilation,
- ✓ Keep the work area clean and free of rags, papers, solvents,
- ✓ Do not operate electrical switches in the presence of vapors or during removal,
- ✓ Immediately stop the application in the presence of arcs,
- ✓ Store all liquids outside the work areas.
- ✓ Use products whose flash point is as high as possible to avoid any risk of formation of flammable gases and vapors (consult the product safety data sheets).
- ✓ To equip the drums with a lid to reduce the diffusion of gases and vapors in the cabin.
- ✓ It is forbidden to pump explosive materials

Hazards of toxic products



Toxic products or vapors can cause serious injury through contact with the body, in the eyes, under the skin, but also by ingestion or inhalation. It is imperative:

- ✓ To know the type of product used and the dangers it represents,
- ✓ Store the products to be used in appropriate areas,
- ✓ Contain the product used in the application in a container designed for that purpose,
- ✓ Treat product waste with the legislation of the country where the equipment is used,
- ✓ To wear protective clothing designed for that purpose,
- ✓ Wearing goggles, hearing protectors, gloves, shoes, coveralls and masks for the respiratory tract.



Attention

The use of halogenated hydrocarbon solvents and products containing these solvents in the presence of aluminum or zinc is prohibited.

Failure to follow these instructions exposes the user to the risk of explosion resulting in serious injury or death.

2.2 Integrity of the material

Material recommendations



Protectors are put in place for safe use of the equipment.

The manufacturer can not be held responsible in case of:

- ✓ Bodily injury.
- ✓ As well as breakdowns and / or damage to the equipment resulting from the destruction, the misuse or the total or partial withdrawal of the protectors.

Pump

It is imperative to be aware of the compatibility of the motors and pumps before coupling them together as well as the special safety instructions. These instructions can be found in the instruction manuals of the pumps.

The air motor is intended to be coupled to a pump. Never modify the coupling system. Keep hands away from moving parts. The moving parts must be kept clean. Before commissioning or using the motor pump, read carefully the DECOMPRESSURIZATION PROCEDURE. Check the proper operation of the pressure relief and bleed air valves.

Tubing

Recommendations

- ✓ Keep hoses away from traffic areas, moving parts and hot areas.
- ✓ Never subject hoses being produced to temperatures above 80°C or below 0°C.
- ✓ Do not use hoses to pull or move equipment.
- ✓ Tighten all connections and hoses and couplings before operating equipment.
- ✓ Check hoses regularly and replace if damaged.
- ✓ Never exceed the maximum working pressure (MWP) stated on the hose.
- ✓ When fitting the hoses and the gun: PPE must be worn.
- ✓ Tighten to full stop (hoses + gun).

Products implemented

Given the diversity of the products implemented by the users and the impossibility of listing all the characteristics of the chemical substances, their interactions and their evolution over time SAMES KREMLIN can not be held responsible:

- ✓ The poor compatibility of materials in contact.
- ✓ inherent risks to staff and the environment.
- ✓ Wear and tear, maladjustment, malfunction of equipment or machines and the quality of the finished product.

The user will have to identify and prevent the potential dangers inherent to the implemented products such as /



- ✓ Toxic vapors.
- ✓ Fire.
- ✓ Explosions.

It will determine the risks of immediate reactions or due to repeated exposures to the staff.

SAMES KREMLIN declines any responsibility, in case of:

- ✓ Bodily or psychic injuries.
 - ✓ Direct or indirect material damage due to the use of chemical substances.
-

3 Environment

The equipment must be installed on a horizontal, stable and flat ground (eg concrete slab).

Non-moving equipment must be fixed to the ground by suitable fasteners (spit, screws, bolts, ...) to ensure their stability during use.

To avoid risks due to static electricity, the equipment and its components must be grounded.



- ✓ **In combination with a pneumatic motor, the hydraulics will be earthed via the earth cable of this motor.** This earth cable must be connected to a safe earth.
- ✓ Have the earth continuity checked by a qualified electrician. If earth continuity is not assured, check terminal, wire and grounding point. Never operate the equipment without solving this problem.



- ✓ **Do not store** more flammable products than necessary inside the work area.
- ✓ These products must be stored in **approved containers** and grounded.
- ✓ Use only grounded **metal buckets** for the use of rinse solvents.
- ✓ **Cartons and papers are to be banned.** Indeed they are very bad conductors, even insulators.

Material marking



Each device is equipped with a identification plate with the name of the manufacturer, the reference of the device, important information for the use of the device (pressure, power, ...) and sometimes against the pictogram shown below.

The equipment is designed and manufactured with high quality materials and components that can be recycled and reused.

European Directive 2012/19 / EU applies to all devices marked with this logo (crossed out bin). Find out about the collection systems available for electrical and electronic devices.

Comply with the rules in your area and **do not dispose of old appliances with household waste**. Proper disposal of this old device will help prevent adverse effects on the environment and human health.

4 Available Configurations

4.1 Rexson parts number of High Viscosity Pumps

Presentation of the pompe REXSON 2B225

A very versatile pump, the REXSON 2B225 hydraulic is used for airless applications as well as for the extrusion of thick products (<50000 cP*).

Different configurations are available.

* 1 cP = 1 mPa.s

Significant designation

REX	2B	0225	-	□	-	□	-	□	-	□
------------	-----------	-------------	---	---	---	---	---	---	---	---

Ex : R E X 2B 0225 - 15 - SS - FP - 01

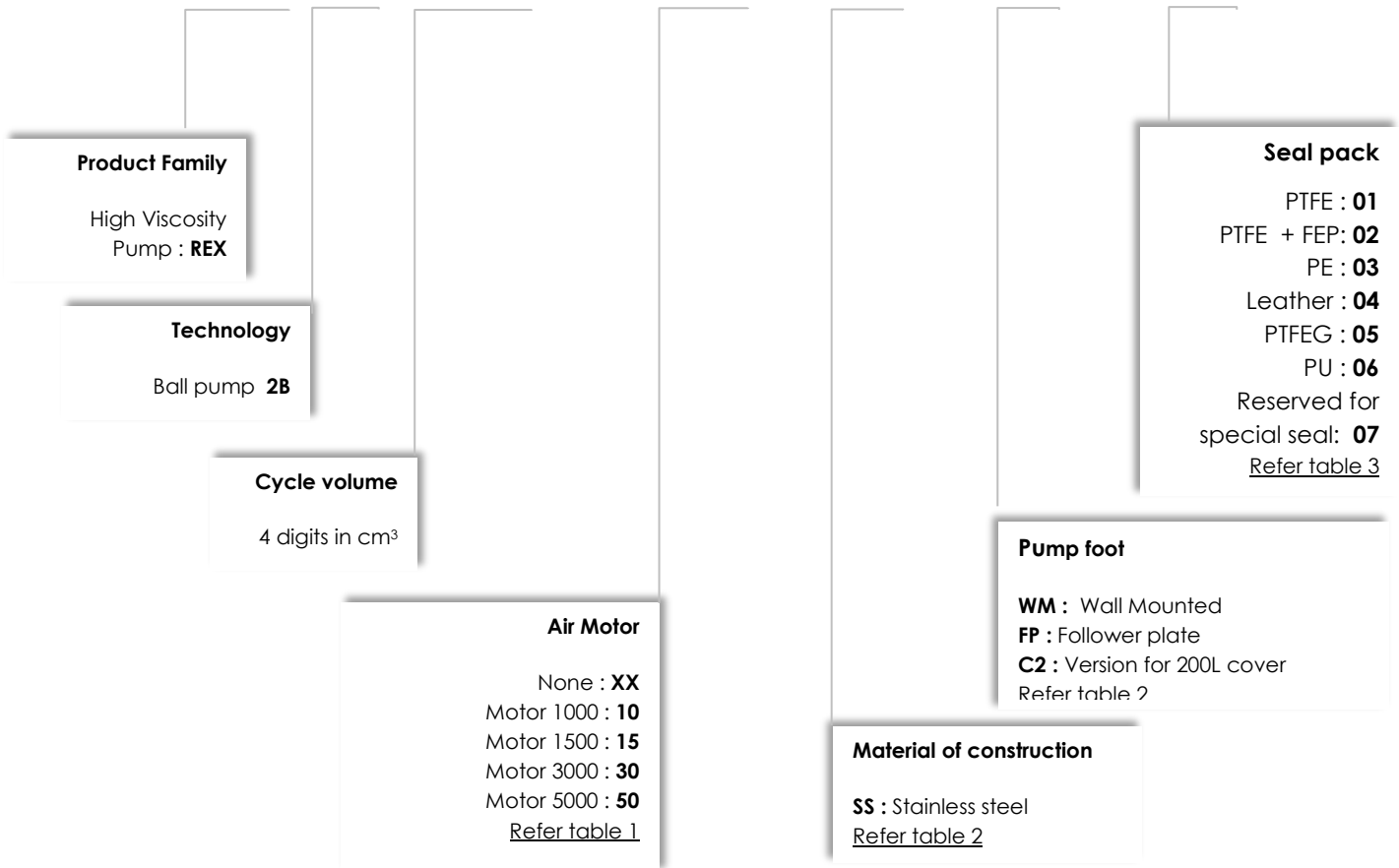

4.2 Table 1 Fluid Section-Air Motor Selection

Available Motors		Pressure Ratio	Maximum Air Inlet Pressure		Maximum Outlet Fluid Pressure		Documentation reference
			bar	psi	bar	psi	
XX	NONE	-	-		-		-
10	MOTOR 1000	4 : 1	6	100	24	300	582142110
15	MOTOR 1500	8 : 1	6	100	50	700	582141110
30	MOTOR 3000	16 : 1	6	100	100	1400	582140110
50	MOTOR 5000	30 : 1	6	100	180	2600	582146110

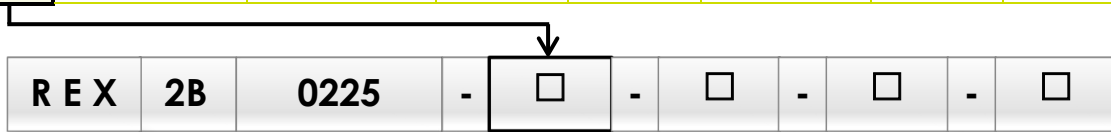

4.3 Table 2 Fluid Section – Pump Foot & Material Selection

Available foot pump		Available material	
		SS	Stainless steel
WM	Wall mounted	✓	
FP	Follower plate	✓	
C2	Drum Cover 200L	✓	



4.4 Table 3 Seals Packs Selection

	Available Seals Pack	Static seals "O"-rings	Upper seals packing	Piston seals packing
01	PTFE	FKM	PTFE	PTFE
02	PTFE + FEP	FEP	PTFE	PTFE
03	PE	FKM	PTFE et PE	PTFE et PE
04	Leather	FKM	Leather and PE	Leather and PE
05	PTFEG	FKM	PTFEG	PTFEG
06	PU	FKM	PU and PE	PTFEG
07	PTFEG/PE + FEP	FEP	PTFEG and PE	PTFEG and PE



PTFE=Polytetrafluoroethylene (Teflon like properties) / PTFEG=PTFE + Graphite (impregnated)
 PE=Polyethene (UHMWPE) / FKM=Flouroelastomer (Viton like properties)
 PU=Polyurethane / PTFEV=PTFE + Glass (impregnated)
 FEP=Encapsulated O-Ring (Teflon like properties over Viton or Silicone)

5 Identification



5.1 Description of the marking of the plate

Principles

This equipment complies with the following provisions:

- ✓ Machinery Directive (2006/42 / EC),
- ✓ Safety of machinery - Basic terms, general implementation guidelines DIN EN ISO 12100 T1/T2
- ✓ ATEX Directive (2014/34 / EU: II 2 G - Group II, Category 2, Gas).

 <p style="text-align: center; font-size: small;">STAINES FRANCE</p> <div style="display: flex; align-items: center; gap: 10px;"> ○ CE Ex II2G IIA T3 </div>	<p>POMPE / PUMP REF / SERIE</p> <div style="border: 1px solid black; height: 20px; width: 100%;"></div> <p>MAX.PRES.(Bar/Psi)</p> <p>RAPPORT RATIO</p> <div style="border: 1px solid black; width: 100%; height: 20px;"></div>	<div style="border: 1px solid black; height: 20px; width: 100%;"></div> <p>PROD</p> <div style="border: 1px solid black; width: 100%; height: 20px;"></div> <p>AIR</p> <div style="border: 1px solid black; width: 100%; height: 20px;"></div>
---	--	--

		Description
SAMES KREMLIN STAINS FRANCE		Manufacturer's mark
POMPE / PUMP REF / SERIE		Pump reference and serial number. The first two digits indicate the year of manufacture.
MAX. PRES. (Bar/Psi)	PROD	Maximum product pressure (Bar/Psi)
	AIR	Maximum air pressure (Bar/Psi)
RAPPORT / RATIO		Pump pressure ratio
CE		EC: European conformity
		 : Use in explosive area II : group II 2 : category 2
		Surface material intended for an environment in which explosive atmospheres due to gases, vapors, mists are likely to occasionally occur during normal operation. G : gas
IIA T3		IIA : Reference gas for equipment qualification T3 : Maximum surface temperature 200 ° C / 392°F

5.2 Correspondence table New part number / Significant designations

New Part Number		Significant Designation
61 MO 0225 M S F 000		REX2B0225-MO-MA-FO-SE
	Options	
MO	Motor	MO
40	MOT1000	10
41	MOT1500	15
42	MOT3000	30
43	MOT5000	50
M	Material	MA
2	Stainless Steel	SS
S	Seal	SE
1	PTFE	01
2	PTFE + FEP	02
3	PTFE/PE	03
4	Leather	04
5	PTFE G	05
6	PU	06
7	PTFEG/PE + FEP	07
F	Foot	FO
1	Wall mounted	WM
2	Follower plate Ø 80 mm	FP
6	200L Cover	C2

	Documentation Reference
Air Motor 1000	582142110
Air Motor 1500	582141110
Air Motor 3000	582140110
Air Motor 5000	582146110

5.3 Correspondence table Existant part number / Significant designations

Existant part number	Significant designation	Motor	Material	Foot	Seal
421 351 730 101	REX2B0225-15-SS-WM-01	MOT1500 8 : 1	SS Stainless Steels	WM Wall mounted	01 PTFE
431 351 730 101	REX2B0225-30-SS-WM-01	MOT3000 16 : 1	SS Stainless Steels	WM Wall mounted	01 PTFE
451 251 731 301	REX2B0225-50-SS-WM-01	MOT5000 30 : 1	SS Stainless Steels	WM Wall mounted	01 PTFE
105 173 01 02	REX2B0225-XX-SS-WM-02	NONE	SS Stainless Steels	WM Wall mounted	02 PTFE + FEP
421 351 730 102	REX2B0225-15-SS-WM-02	MOT1500 8 : 1	SS Stainless Steels	WM Wall mounted	02 PTFE + FEP
431 351 730 102	REX2B0225-30-SS-WM-02	MOT3000 16 : 1	SS Stainless Steels	WM Wall mounted	02 PTFE + FEP
105 173 01 03	REX2B0225-XX-SS-WM-03	NONE	SS Stainless Steels	WM Wall mounted	03 PTFE/PE
431 351 730 103	REX2B0225-30-SS-WM-03	MOT3000 16 : 1	SS Stainless Steels	WM Wall mounted	03 PTFE/PE
105 173 01 04	REX2B0225-XX-SS-WM-04	NONE	SS Stainless Steels	WM Wall mounted	04 Leather
411 351 730 104	REX2B0225-10-SS-WM-04	MOT1000 4 : 1	SS Stainless Steels	WM Wall mounted	04 Leather
451 251 731 304	REX2B0225-50-SS-WM-04	MOT5000 30 : 1	SS Stainless Steels	WM Wall mounted	04 Leather
421 351 730 403	REX2B0225-15-SS-FP-03	MOT1500 15 : 1	SS Stainless Steels	FP Follower plate	03 PTFE/PE
431 351 731 003	REX2B0225-30-SS-FP-03	MOT3000 16 : 1	SS Stainless Steels	FP Follower plate	03 PTFE/PE

6 Technical characteristics and performance

6.1 General characteristics

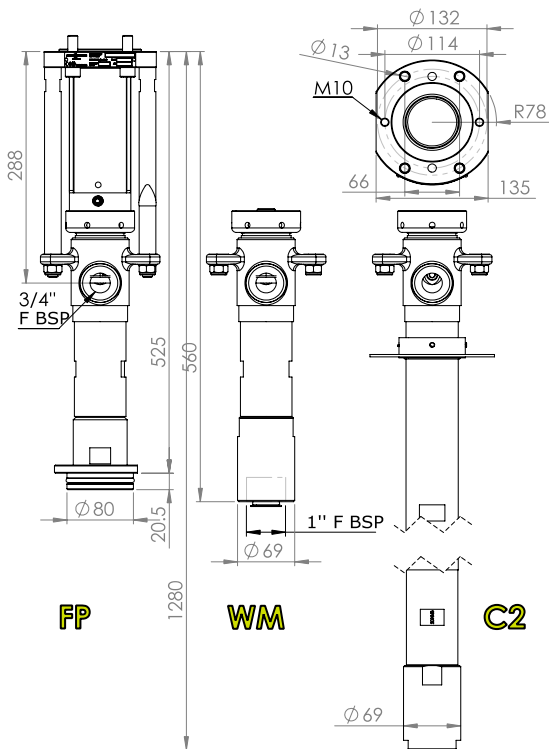

Technical characteristics	
Volume per cycle	225 cm ³ / 7,61 oz
Stroke	120 mm / 4,72 in
Fluid outlet connections	3/4" F BSP
Weight	25 kg / 55,1 lb
Maximum fluid temperature	80°C / 176°F
Wetted parts	Depending on Materials of construction and seals kit
Packings	Depending on seals kit

Available Motors		Motor selection				
		XX	10	15	30	50
		NONE	MOTOR 1000	MOTOR 1500	MOTOR 3000	MOTOR 5000
Pressure Ratio		-	4 : 1	8 : 1	16 : 1	30 : 1
Maximum Air Inlet Pressure	bar	-	6	6	6	6
	psi	-	100	100	100	100
Maximum Outlet Fluid Pressure	bar	-	24	50	100	180
	psi	-	300	700	1400	2600
Minimum Outlet Fluid Pressure	bar	-	6	13	24	45
	psi	-	87	182	349	653
Complete Pump Weight	Kg	-	30,5	30,5	32,2	46
	Lbs	-	67.3	67.3	71	101.4
Air consumption 15 Cycles/min @ 4 bar	NL.min-1	-	54	113	216	405
	scfm	-	1,9	4	7,6	14,3
Air inlet fitting	Female BSP	-	1 / 2 "	1 / 2 "	1 / 2 "	3 / 4 "

scfm= Standard cubic feet of gas per minute

(General characteristics - continued)

Pump Foot		Technical characteristic
WM	Wall monted	Inlet F 1"
FP	Follower Plate	Ø 80 mm
C2	Drum Cover	200 Liters

Materials of construction		SS
		Stainless steel
Pump body	Wet Cup	Carbon steel +Zinc treatment
	Upper body	Stainless steel
	Cylinder	Stainless steel chromed
Piston (Upper check)	Piston rod	Stainless steel chromed
	Valve body	Stainless steel
	Valve ball	Stainless steel
	Valve seat	Carbide
Lower valve (Lower check)	Bodys	Stainless steel
	Ball	Stainless steel
	Seat	Stainless steel
Pump Foot		Stainless steel

6.2 Principle of operation

Expected use

These pumps coupled to air or hydraulic motors are intended for transferring or spraying different liquid or pasty products with a desired flow rate and output pressure.

Functional description

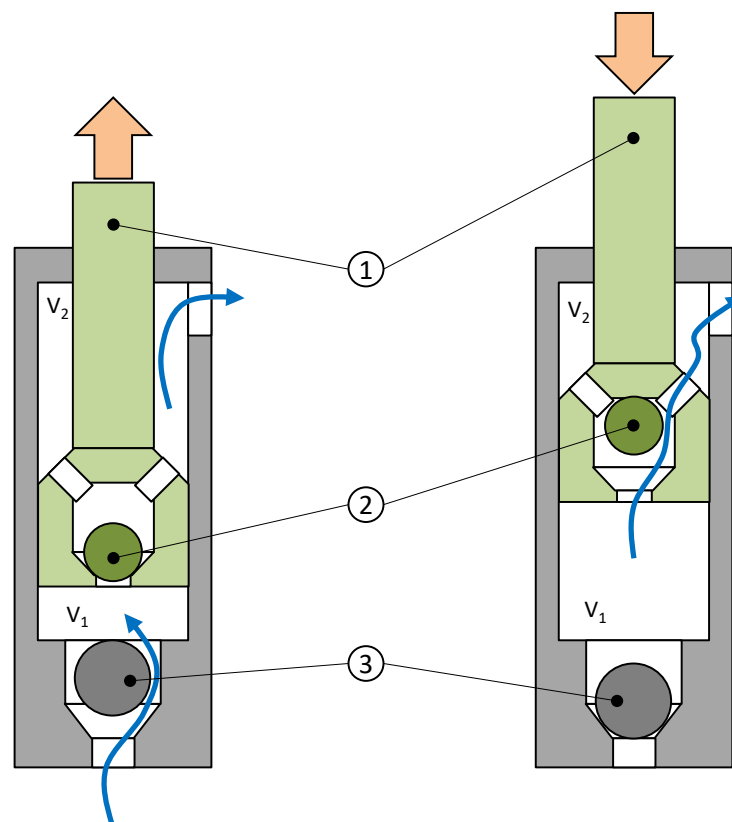

When the piston (1) rises, the upper flap (2) closes and the lower flap (3) opens. The piston (1) expels the product from the upper chamber (V2) to the outside and sucks the product to fill the lower chamber (V1).

When the piston (1) is lowered, the upper flap (2) opens and the lower flap (3) closes. The piston (1) compresses the fluid in the lower chamber (V1) and transfers it to the upper chamber (V2). Since the volume of the upper chamber (V2) is half that of the lower chamber (V1), a volume equivalent to the upper chamber (V2) is expelled from the pump.

**ATTENTION!**

The friction generated by the movement of the product inside the pump and its accessories, as well as that caused by the seals, creates static electricity that can cause fire or explosion. Therefore, the fluid section system must be earthed via the motor ground cable (see the motor instruction manual for its ground connection).

7 Installation

7.1 Handling

Fluid sections of great weight and size must be handled with suitable lifting equipment.

7.2 Connections subsets



- ✓ These fluid sections are intended to be coupled to motors (pneumatic or hydraulic) with compatible stroke.
- ✓ It is imperative to comply with an air motor / hydraulic combination provided by SAMES KREMLIN
- ✓ Make sure that all connections of the pump and fluid section components - cables, hoses and pipes - are installed in such a way that they do not cause people to fall.
- ✓ Make sure that the order in which the cables, hoses and pipes are connected is in accordance with the connection diagram.
- ✓ Make sure that all cable connectors, hose and pipe connections are correctly fitted.
- ✓ Remember that unconnected or incorrectly connected cables, hoses and pipes can lead to malfunctions that endanger the safety of operating personnel.

7.2.1 Fluid supply connection



- ✓ If the supply pressure is higher than the max. pressure, it is necessary to install a fluid pressure regulator the closest possible of the equipment.
 - ✓ Ensure that a short product hose reduces pressure fluctuations and pressure drops.
 - ✓ Make sure that the fluid supply is properly made. The nominal size of the fitting to be used depends on the nominal size of the fluid hose.
-

7.2.2 Air supply connection

- ✓ Ensure that in bound air supply and hose are of correct size to reduce pressure fluctuations and pressure drops.
-

7.3 Storage

Pump

Place the equipment away from moisture after closing the various air inlets and various openings (plugs).

Storage before installation:

- ✓ Storage ambient temperature: 0 / +50 ° C.
- ✓ Protect the unit against dust, water runoff, moisture and shocks.

Storage after installation:

- ✓ Protect the unit against dust, water runoff, moisture and shocks.
-

8 Commissioning



The fluid sections are integrated in a system, if necessary refer to any additional instructions for further information on commissioning.

Pump

Pumps are tested for operation at the factory using a light weight oil lubricant.

Before commissioning, this lubricant must be removed by flushing with a suitable solvent.

At the end of the day, flush with a suitable solvent.

It is advisable to stop the fluid section in the "low" position in order to prevent the product from taking hold of the piston rod.

Motor

The Air motors are tested before their shipment. Nevertheless:

- ✓ Before coupling the Air motor to a fluid section pump, it is recommended to run the air motor at a low air pressure (1 bar / 14.5 psi max) for a few minutes.
 - ✓ Couple the motor with the recommended pump fluid section.
-

9 Use of the product

9.1 User settings

Wet Cup

Before commissioning, fill the wet cup halfway with lubricant "T".

The wetting cup nut must be tightened moderately. Overtightening quickly damages the gland packing. A wrench is supplied to allow proper tightening.

Tightening of the Wet Cup

- ✓ Verify cup is filled with lubricant T,
 - ✓ Run the pump, then tighten the cup after 10 minutes, again after 1 hour, then after 1 day of operation,
 - ✓ In the event of a leak, the cup must be tightened.
-

Tightening procedure

- ✓ Depressurize the Air motor (see depressurization procedure),
 - ✓ Depressure the product circuit (see depressurization procedure),
 - ✓ Tighten the cup, clean it and fill it with lubricant T,
 - ✓ Close the pump purge circuits,
 - ✓ Open the Air motor air valve.
-

Suction Valve Pin Adjustment

Depending on the viscosity of the medium to be pumped, position the lower plug pin as shown below.

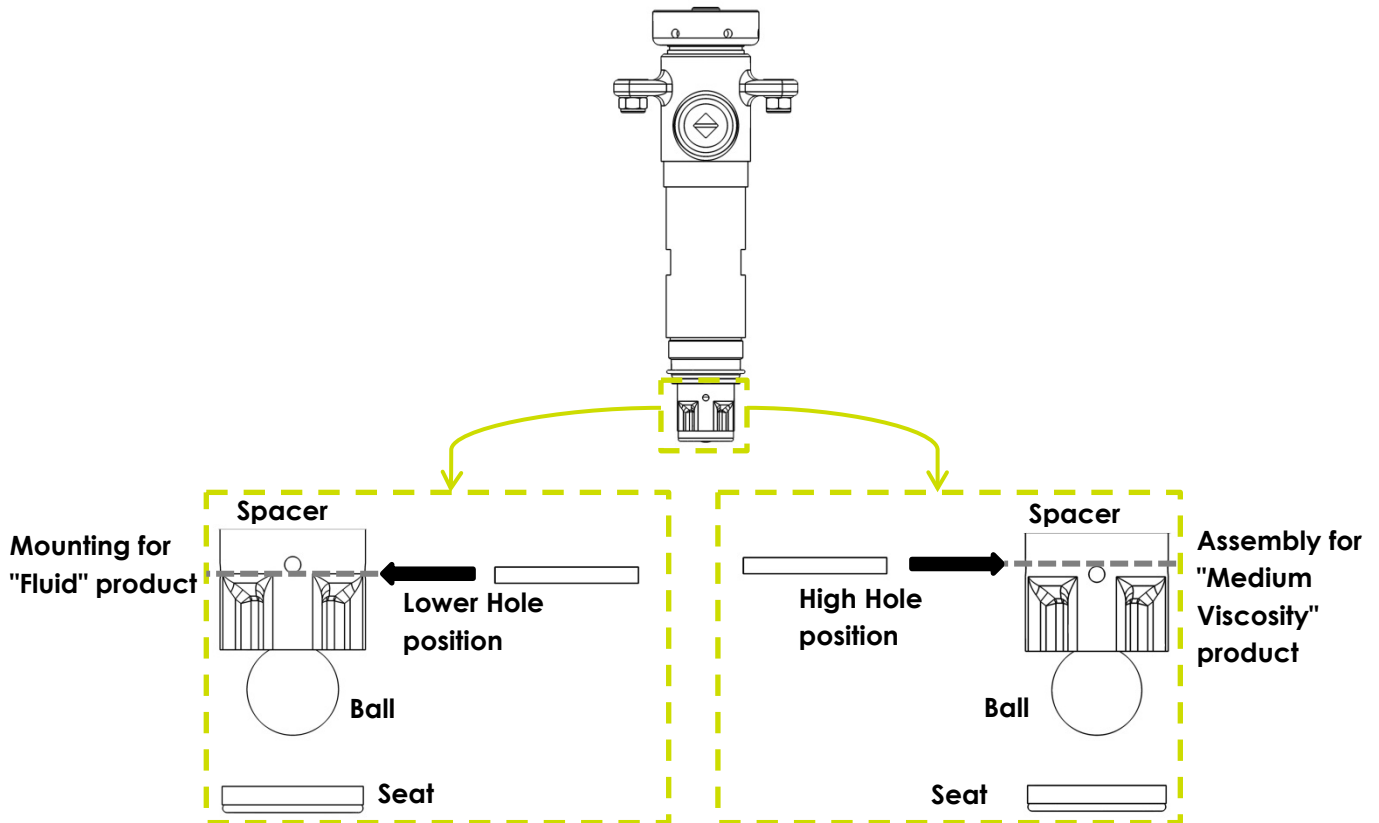

(For a full description of spare parts, see Part 12 - Spare Parts)



As this pump is mainly dedicated to the transfer and application of viscous products, the pin is, when leaving the factory, positioned at the highest point. This allows the ball to move far away from the seat and allow the liquid to enter the pump during suction without hindering its passage.

9.2 Safety in production



Guards (motor cover, coupling guard, housings, ...) are set up for safe use of the equipment.

The manufacturer can not be held responsible in case of bodily injury as well as breakdowns and / or damage of the material resulting from the destruction, the occultation or the total or partial removal of the protectors.

9.3 Start up



Pumps are tested for operation at the factory using a light weight oil lubricant.

Before commissioning, this lubricant must be removed by flushing with a suitable solvent.

At the end of the day, flush with a suitable solvent.

It is advisable to stop the fluid section in the "low" position in order to prevent the product from taking hold of the piston rod.

9.4 Shutdown procedure

Pump



To avoid the risk of personal injury, material injections, injuries caused by moving parts or electric arcs, it is imperative that the following procedure be followed before any work is carried out when shutting down the system, assembling, cleaning or changing the nozzle.

- ✓ Lock the guns (valve, tap...) on OFF.
- ✓ Shut off the air supply through the shut off valve to remove residual air from the motor.
- ✓ Unlock the gun (valve, tap...).
- ✓ Bring the gun (valve, tap...) close to a metal bucket in order to recover the product. Hold it against the wall of the bucket to avoid interrupting the grounding continuity (if necessary, use the wire with clamp to ground the metal bucket).
- ✓ Open the gun (valve, tap) in order to drain the circuit.
- ✓ Lock the gun (valve, tap) in the OFF position.
- ✓ Open the pump drain valve and collect the fluid in a properly grounded metal pail.
- ✓ Leave the bleed valve open during the entire operation.



Check the conformity of the wiring before intervention.

9.5 Diagnostic help / Troubleshooting guide

Possible symptoms of faults / Causes of faults / Remedies to apply

Defaults	Possible causes	Remedies
Leakage at the cup seals	Insufficient tightening of the packing nut	Tighten the cup.
	Incorrect assembly of seals	Check the assembly.
	Damaged or worn seals	Replace them.
	Incorrect selection of the material of the joints	Check compatibility.
The cup seals get rapidly damaged	No lubricant in the cup (pumped product drying on the piston rod).	Clean, replace parts if necessary. When stopping for a long time, stop the pump with the piston in the low position.
	Product compatibility / seals	Check.
The pump is stopped	The fluid is polymerized, hardened, dried in the pump.	Clean the pump, change the parts if necessary.
	The cup is too tightened.	Loosen.
	Broken part(s) in the pump.	Remove, check, replace.
The motor seems to operate but the pump does not deliver product	Internal parts of the motor failing	Check the operating of the motor.
	Defective coupling.	Check coupling.
The pump operates but irregular flow	Valve clogged on the seat, incorrectly mounted or worn.	Check mounting, state of the parts, tightening of parts and seals.
	Air inlet in the suction circuit.	
At stop, pump piston continues to move on going down	Valve worn or incorrectly mounted	Check and replace parts.
	Plug or drain valve not tightened	
At stop, pump piston continues to move on going up	Head piston seals or upper valve worn or incorrectly mounted.	Check and replace parts.
	Plug or drain valve not tightened	

Defaults	Possible causes	Remedies
Pump strokes quickly downward (simple effect working)	Bad feeding of the pump.	Check use parameters of the accessories (pressure on follower plate or suction rod,...). Accessories can be not adapted or clogged.
	Product is too viscous.	Bad definition of the pump.
	Lower valve worn.	Check and replace parts.
	A foreign product obstructs the lower valve.	Clean and check.
Pump strokes quickly upward	Valve worn or damaged.	Check and replace parts.
	A foreign product obstructs the upper valve.	Clean and check.
Pump cycles up and down at different speeds	Valve, head piston seals or cylinder worn.	Replace parts.
	Seals incorrectly mounted or damaged	Check the mounting; change if necessary.
The pump does not deliver enough pressure	Insufficient air pressure to the motor (valve insufficiently open, air leak,...)	Check; adjust.
	Insufficient air inlet on the motor or outlet clogged.(hose not adapted)	Check filter, mounting, hose not adapted.
	Cup or head piston seals too tightened.	Check mounting or loosen cup nut.
Abnormal operating after racing or to elevated temperature.	Head piston or cup seals too tightened, damaged.	Check mounting; reduce pumping rhythm. Replace parts if necessary.
	Product drum empty.	Fill the drum; check the suction circuit and possible air leakage.
Pressure drop when pump strokes downward	Lower valve lifted or process	Displace the pin.
Fluid leakage from the pump body	Cylinder tightened	Check parts and change them if necessary
	No seals or seals damaged	

10 Maintenance



Attention

Before any pump maintenance or service work performed, it is imperative to follow the depressurization procedure and the safety instructions.

Only qualified personnel should be allowed to carry out the following interventions. Observe the safety instructions given in this and all other documentation.

These procedures cover only the most common problems. If the information given here does not solve the problem you are experiencing, please contact your local SAMES KREMLIN representative for assistance.

During prolonged shutdown, stop the pump when the piston is in the low position.



Guards (motor cover, coupling guard, housings, ...) are set up for safe use of the equipment.

The manufacturer can not be held responsible in case of bodily injury as well as breakdowns and / or damage of the material resulting from the destruction, the occultation or the total or partial removal of the protectors.

10.1 Preventive Maintenance Plan



ATTENTION

Before any pump maintenance or service work performed, it is imperative to follow the depressurization procedure and the safety instructions.

Routine maintenance after a certain number of operating hours is recommended.

This is defined by the service department of the user and depends on the product, the working cycle and the usual pressure.

Take note of the disassembly/reassembly of the pump and the spare parts.

Fluid section

Daily

- ✓ Detect leaks at connections.
- ✓ Check the condition of the hoses.
- ✓ Observe the piston rod of the pump. Do not let the product dry onto the piston rod.
- ✓ Check the lubricant level inside the cup (keep it at half level).
Fill it if necessary. It is normal for this lubricant to stain.
- ✓ Tighten the packing cup moderately with the supplied wrench, if necessary.
- ✓ Check the tightness of the components.
- ✓ If the pump is equipped with a pusher plate:
 - check the condition of the plate seal,
 - clean the top and bottom of the follower plate.
- ✓ Operate all valves in the system.
- ✓ Clean the site and the environment.

Twice a month

- ✓ If the lubricant is strongly colored in the cup, renew it.
- ✓ Check that the cup remains clean and clean it regularly with solvent after draining the lubricant.

10.2 General preconisation maintenance

**ATTENTION**

Before any intervention, it is imperative to follow the decompression procedure and the safety instructions.

Before each reassembly

- ✓ Clean the parts with the appropriate cleaning solvent.
 - ✓ Fit new seals if necessary, after greasing them.
 - ✓ Grease the piston and the inside of the cylinder to avoid damaging the seals.
 - ✓ Fit new parts if necessary.
-

11 Disassembly / Reassembly Operation



ATTENTION

Before any intervention, it is imperative to follow the decompression procedure and the safety instructions.



ATTENTION

The equipment is subject to the ATEX directive and must not be modified under any circumstances.

Failure to comply with this recommendation does not engage our responsibility.

Before each reassembly:

- Clean the parts with appropriate cleaning solvent.
- Fit new seals if necessary, after greasing them.
- Grease the piston and the inside of the cylinder to avoid damaging the seals (see table below),
- Fit new parts if necessary.

Greases and thread lockers designations

Index	Instruction	Description	Part number
A 1	PTFE grease	'TECHNI LUB' grease (10 ml / 0.0026 US gal)	560.440.101
A 2	Anti-seize grease	Grease box (450 g / 0.99 lb)	560.420.005
C 1	Medium strength Aneorobic Pipe sealant	Loctite 5772 (50 ml / 0.013 US gal)	554.180.015

Fluid Section wall mounted and Follower plate : all versions

REX2B0225-□-□-WM-□
REX2B0225-□-□-FP-□

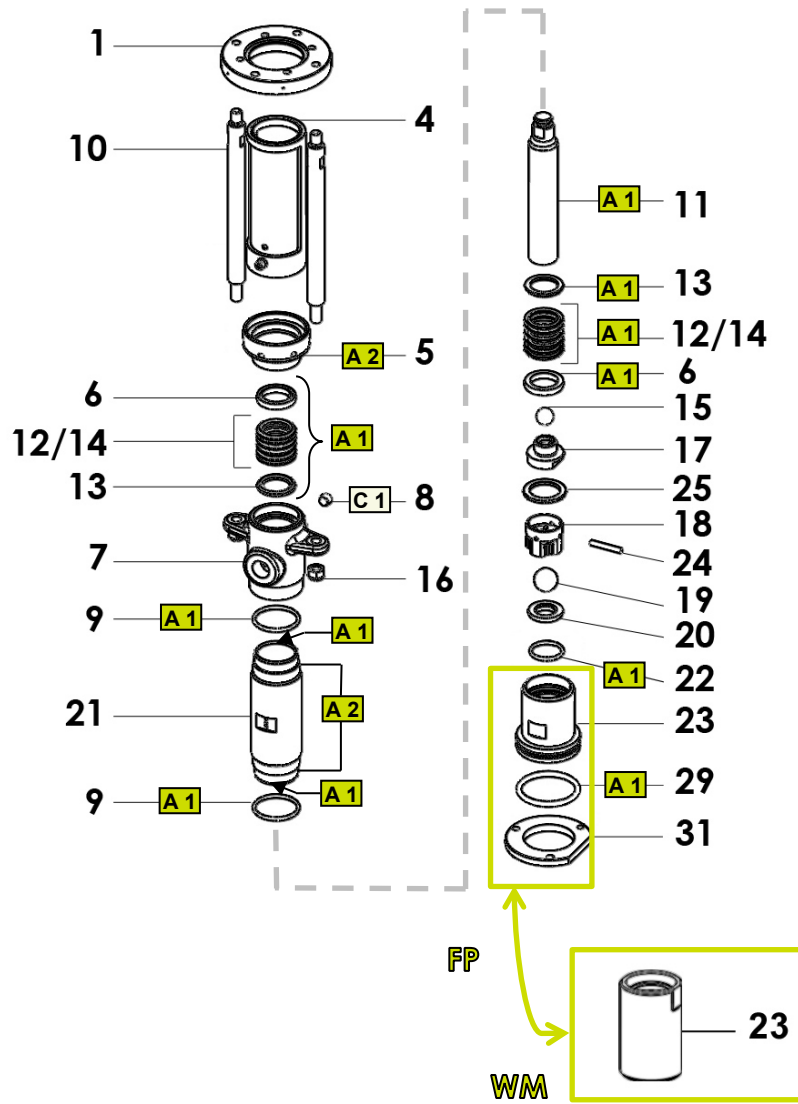

(For a full description of spare parts, see Part 12 - Spare Parts)

Fluid Section 200 L cover

REX2B0225-□-□-C2-□

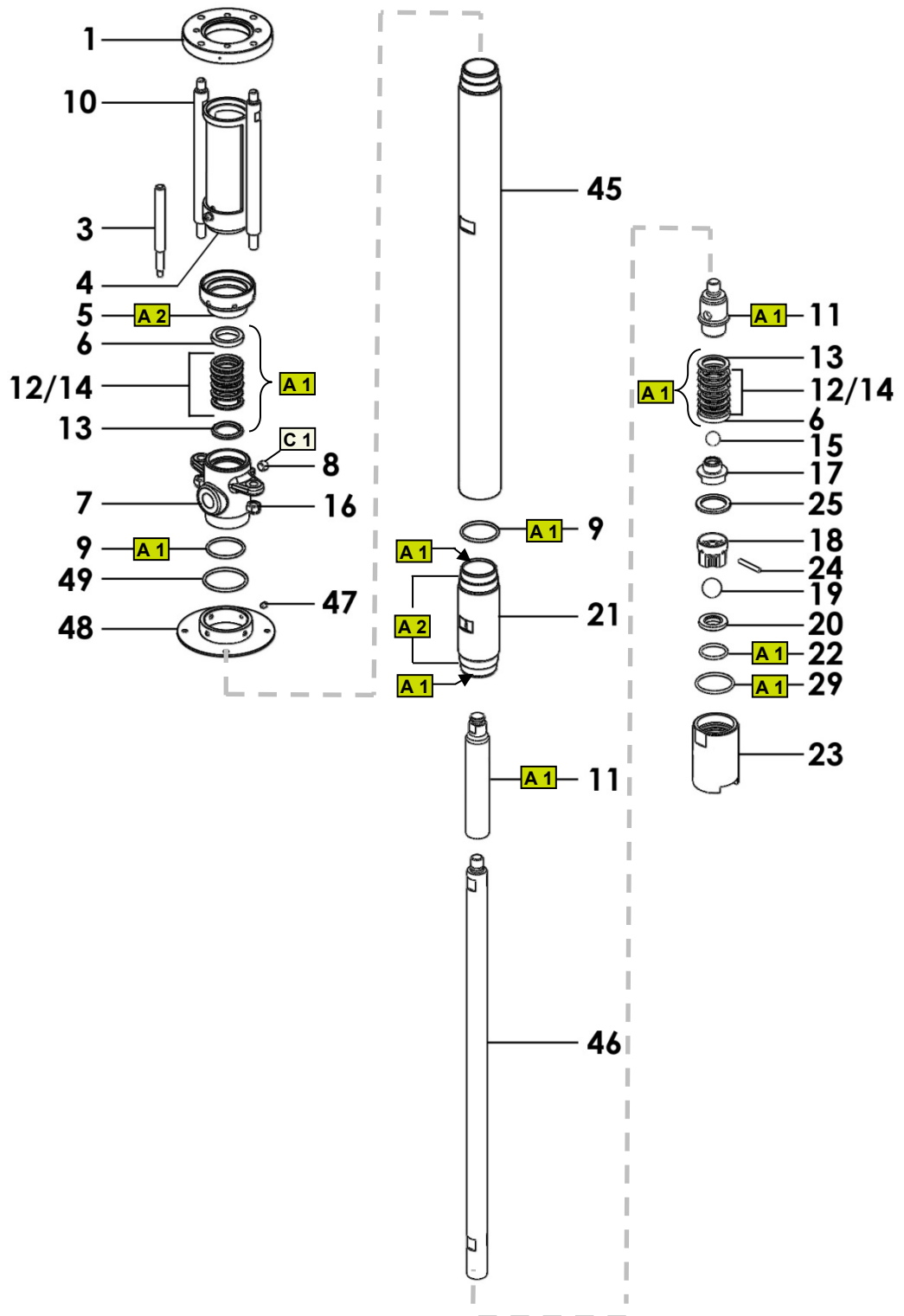

(For a full description of spare parts, see Part 12 - Spare Parts)

Disassembly of the pump

- ✓ Unscrew the 2 nuts (16) and put aside the flange (1), the tie rods (10) and the protection (4),
- ✓ Clamp the pump horizontally through the body with a vice (7),
- ✓ Unscrew the foot-valve body assembly (23) taking off if necessary the washer (25),
- ✓ Take off the piston (11) downwards,
- ✓ Put aside the cylinder (21).

Lower valve

- ✓ Push the ball (19) to remove the spacer (18),
- ✓ Take off the seat (20), the seal (22) and the pin (24),
- ✓ Put aside the seal (9),
- ✓ Clean the parts, check them if they are damaged or worn.
- ✓ Reinstall the parts in the reverse order of the disassembly sequence.

Wet cup seals

- ✓ Unscrew the wetting cup nut (5),
- ✓ Take off the washers (6 & 13),
- ✓ Put aside the seals,
- ✓ Clean the parts, check them if they are damaged or worn.
- ✓ Reinstall the parts in the reverse order of the disassembly sequence.

Piston head

- ✓ Unscrew the seat (17),
 - ✓ Take off the ball (15), the washers (6 & 13) and the seals (14),
 - ✓ Clean the parts, check them if they are damaged or worn.
-

Reassembly of the fluid section :

- ✓ Lubricate the wetting cup seals and the piston head seals,
 - ✓ Slide the piston rod (11) assembly inside the body (7), push it upwards,
 - ✓ Screw the cylinder (21) (to top) into the body (7),
 - ✓ Screw the foot-valve body (23) assembly to top, tighten slightly,
 - ✓ Reinstall the protection (4), the connection flange (1) and the tie-rods (10). Screw the 2 nuts (16),
 - ✓ Reassemble the pump to the pneumatic motor.
-

12 Spare parts

Use only genuine SAMES KREMLIN accessories and spare parts designed to withstand the pump's operating pressures.

Fluid Section wall mounted and Follower plate : all versions

REX2B0225-□-□-WM-□
REX2B0225-□-□-FP-□

WARNING: these parts are not supplied with the fluid section alone as they depend on the engine.

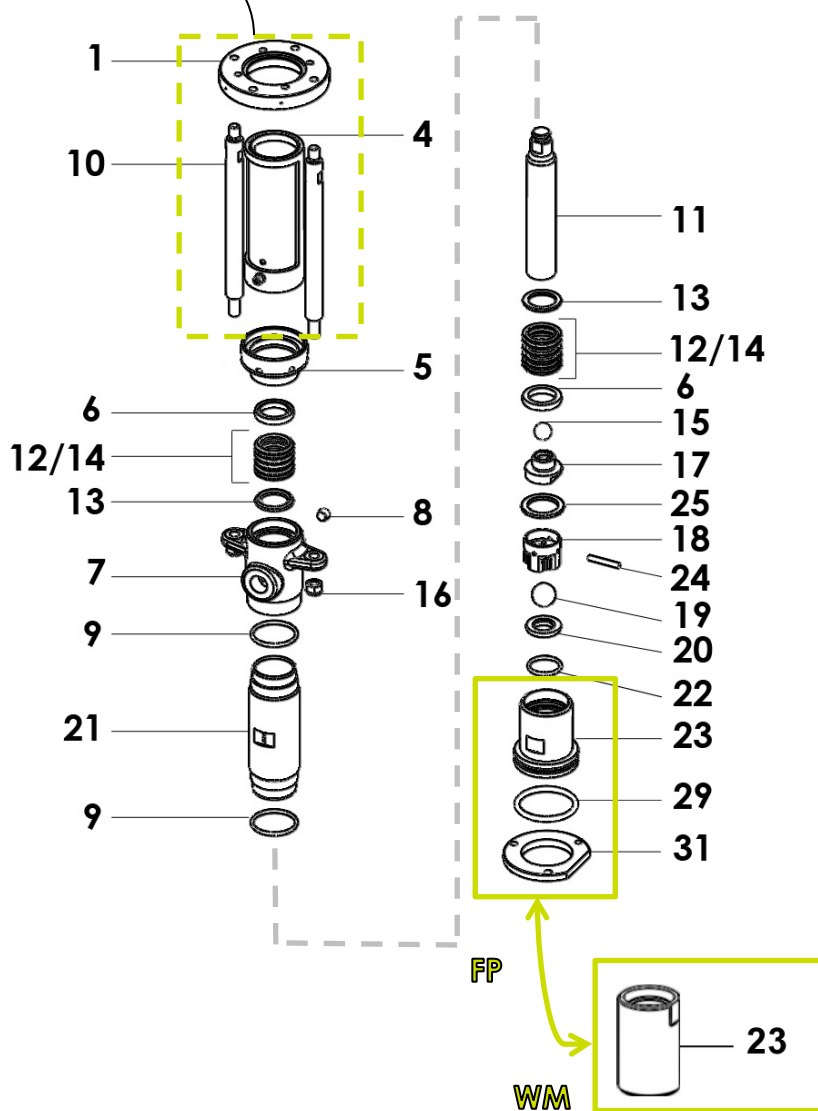

Fluid Section 200 L cover

REX2B0225-□-□-C2-□

WARNING: these parts are not supplied with the fluid section alone as they depend on the engine.

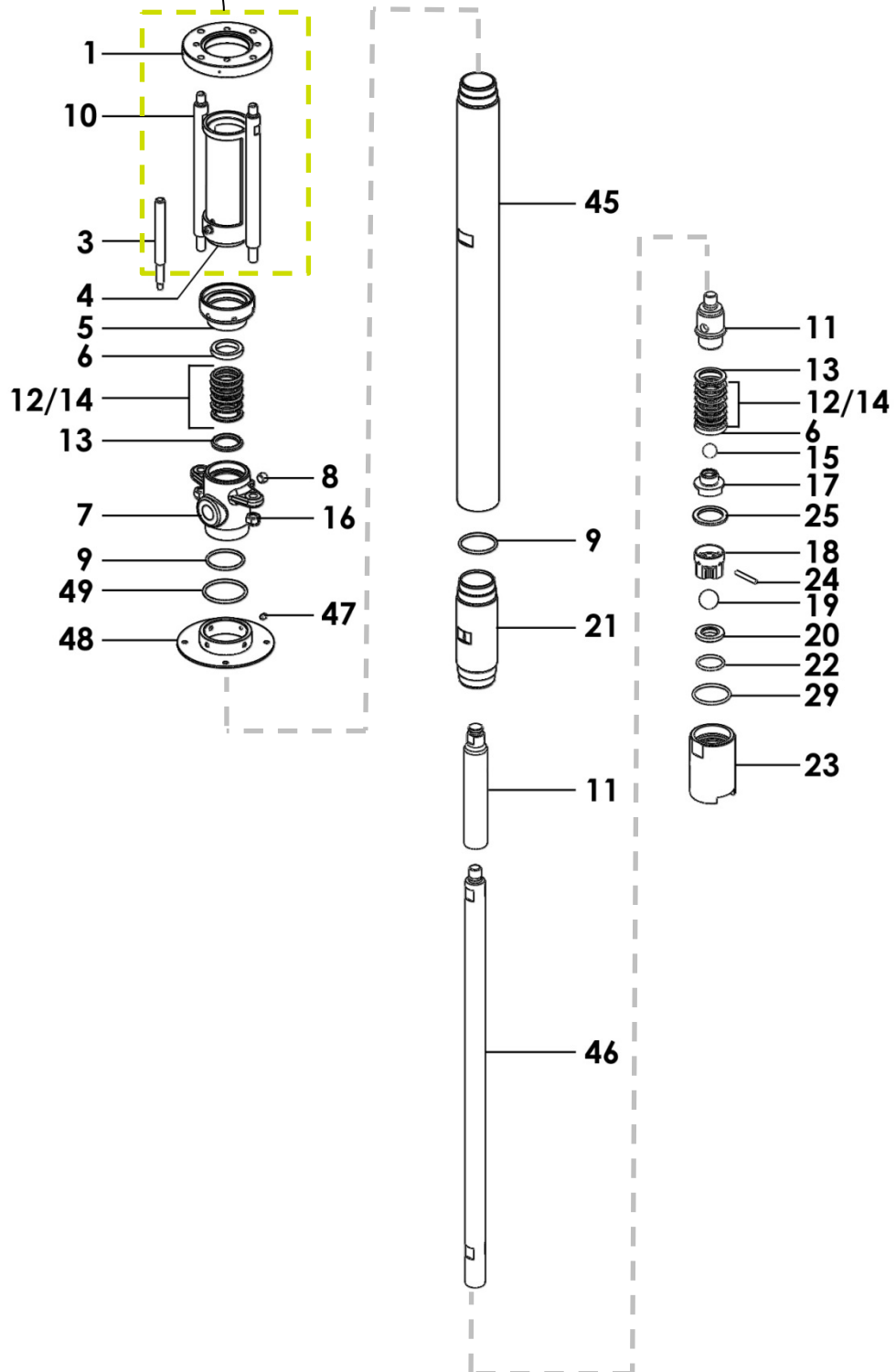

REX2B0225 - □ - □ - □ - □



WM	FP	C2
Wall Mounted	Follower Plate	200 L cover

Ind.	Description	# Ref.			Qty	Spare part maintenance level**
**1	Connection flange	See motor coupling kit table			1	3
**4	Protection	See motor coupling kit table			1	3
5	Wetting cup nut	044 220 005			1	3
*6	'F' washer	N.S. (209 651)			2	1
7	Pump body	209 643			1	3
8	Plug	906 314 211			1	3
9	O-Ring	According to seals pack				1
**10	Tie-rod	See motor coupling kit table			2	3
*11	Piston	209 645			1	2
*12	Chevron seal	According to seals pack				1
*13	'M' washer	See repair kit table.			2	1
*14	Chevron seal	According to seals pack				1
*15	Ball	87 320			1	1
16	Lock nut	88 335			2	3
*17	Upper piston seal	209 649			1	1
18	Spacer	209 611			1	3
*19	Ball	87 328			1	1
*20	Lower seat	209 612			1	1
21	Cylinder	209 648			1	2
22	O-Ring	N.S. (84 390)			1	1
23	Foot-valve body	209 650	210 059	209 650	1	2
*24	Pin	209 610			1	1
25	Washer	209 653			1	3
*29	O-Ring	N.S. (84 183)			1	1
30	Adjustment block	210 341			1-4	1
31	Valve body flange	-	210 056	-	1	3
45	Cylinder extension	-	-	210 306	1	3
46	Piston extension	-	-	210 346	1	3
47	Screw M6x10	-	-	88 267	4	3

* Recommended maintenance parts.
 **Level 1 : Preventive maintenance

N S: Denotes parts are not serviceable.
 Level 2 : Corrective maintenance Level 3 : Exceptional maintenance

REX2B0225



		WM	FP	C2		
		Wall Mounted	Follower Plate	200 L cover		
Ind	Description	# Ref.			Qty	Spare part maintenance level**
48	Support plate	-	-	205 044	1	3
49	O-ring seal	-	-	84 002	1	1
*	Seals pack	Depending upon choice - refer to table (Ind. 9, 12, 14, 22, 29,30)			1	1
*	Repair kit	105 433 (Ind. 6, 13, 15, 17, 19, 20, 24)			1	1

* Recommended maintenance parts.

**Level 1 : Preventive maintenance

N S: Denotes parts are not serviceable.

Level 2 : Corrective maintenance

Level 3 : Exceptional maintenance

Lower adapter flange

Ind.	Description	# Ref.	Qty	Spare part maintenance level**
-	Lower adapter flange for motors 1000, 1500, 3000	144 246 295	1	3
**1	▪ Connecting flangen	N.S. (209 600)	1	
**4	▪ Protective housing	N.S. (044 200 010)	1	
**10	▪ Tie-rod	N.S. (209 601)	2	

* Recommended maintenance parts.

**Level 1 : Preventive maintenance

N S: Denotes parts are not serviceable.

Level 2 : Corrective maintenance

Level 3 : Exceptional maintenance

Ind.	Description	# Ref.	Qty	Spare part maintenance level**
-	Lower adapter flange for motors 5000	144 245 295	1	3
**1	▪ Connecting flangen	N.S. (210 447)	1	
**4	▪ Protective housing	N.S. (044 200 010)	1	
**10	▪ Tie-rod	N.S. (209 601)	2	

* Recommended maintenance parts.

**Level 1 : Preventive maintenance

N S: Denotes parts are not serviceable.

Level 2 : Corrective maintenance

Level 3 : Exceptional maintenance

Repair Kit

Ind.	Description	# Ref.	Qty	Spare part maintenance level**
-	Repair kit	105 433	1	2
*6	▪ 'F' washer	209 651	2	
*13	▪ 'M' washer	209 625	2	
*15	▪ Ball	87 320	1	
*17	▪ Upper piston seal	209 649	1	
*19	▪ Ball	87 328	1	
*20	▪ Lower seat	209 612	1	
*24	▪ Pin	209 610	1	

* Recommended maintenance parts.

**Level 1 : Preventive maintenance

N S: Denotes parts are not serviceable.

Level 2 : Corrective maintenance

Level 3 : Exceptional maintenance

Recommended Seals pack

Code	Composition	Use
01	PTFE (+ FKM)	Solvent - Ether - Ketone - Aromatic alcohol - some varnishes and paints
02	PTFE (+ FKM / FEP)	Solvent - Ether - Ketone - Aromatic alcohol - some varnishes and paints, PU paints - Pharmacy - Cosmetics - Some foodstuffs
03	PTFE + PE (+ FKM)	Epoxy glue - Butyl - Silicone - Some varnishes - Paint
04	PE + LEATHER (+ FKM)	Paint - Varnishes - Grease - Oil - Ink - Hydro soluble paint
05	GRAPHITED PTFE (+ FKM)	Paints - Varnishes - Inks - PVC compounds - Butyl
06	PU + GRAPHITED PTFE (+ FKM)	Mastics - PVC - Butyl
07	PTFEG/PE + FEP*	PU paints - Pharmacy - Cosmetics - Some foodstuffs, Mastics - PVC - Butyl

* Allows a better mechanical resistance

Accessory

Ind.	Description	# Ref.	Qty
-	Bottle of lubricant T (125 ml / 0,034 oz)	149 990 020	1

Seals pack composition: 01 to 03

Seals pack :		01			02			03		
# :		105 253			105 254			105 255		
Ind.	Description	Qté	#	Material	Qty	#	Material	Qty	#	Material
9	O-Ring	2	84 183	FKM	2	84 394	FKM / FEP	2	84 183	FKM
12	Cup packing	6	209 655	PTFE	6	209 655	PTFE	3	209 655	PTFE
								3	209 656	PE
14	Piston packing	6	209 655	PTFE	6	209 655	PTFE	3	209 655	PTFE
								3	209 656	PE
22	O-Ring	1	84 390	PTFE	1	84 390	PTFE	1	84 390	PTFE
29	O-Ring	1	909 130 540**	FKM	1	909 130 540**	FKM	1	909 130 540**	FKM
		1	Or 84 183**	FKM	1	Or 84 394**	FKM	1	Or 84 183**	FKM
30	Adjustment block	4*	210 341	ST STEEL	4*	210 341	ST STEEL	4*	210 341	ST STEEL

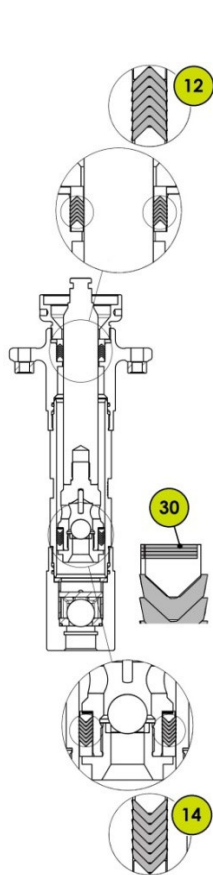

↓			↓			↓		
12			12			12		
PTFE	→	^	PTFE	→	^	PTFE	→	^
PTFE	→	^	PTFE	→	^	PE	→	^
PTFE	→	^	PTFE	→	^	PTFE	→	^
PTFE	→	^	PTFE	→	^	PE	→	^
PTFE	→	^	PTFE	→	^	PTFE	→	^
PTFE	→	^	PTFE	→	^	PE	→	^
14			14			14		
PTFE	→	∨	PTFE	→	∨	PE	→	∨
PTFE	→	∨	PTFE	→	∨	PTFE	→	∨
PTFE	→	∨	PTFE	→	∨	PE	→	∨
PTFE	→	∨	PTFE	→	∨	PTFE	→	∨
PTFE	→	∨	PTFE	→	∨	PE	→	∨
PTFE	→	∨	PTFE	→	∨	PTFE	→	∨

* Quantity to be assembled as required** According to pump foot

Seals pack composition: 04 to 06

Seals pack: # :		04 105 257			05 105 258			06 105 259		
Ind.	Description	Qty	#	Material	Qty	#	Material	Qty	#	Material
9	O-Ring	2	84 183	FKM	2	84 183	FKM	3	84 183	FKM
12	Cup packing	2	209 657	LEATHER	6	209 658	PTFE G	3	84 411	PU
		3	209 656	PE				1	209 659	ACETAL RESIN
14	Piston packing	3	209 657	LEATHER	6	209 658	PTFE G	6	209 658	PTFE G
		3	209 656	PE						
22	O-Ring	1	84 390	PTFE	1	84 390	PTFE	1	84 390	PTFE
29	O-Ring	1	909 130 540**	FKM	1	909 130 540**	FKM	1	909 130 540**	FKM
		1	Or 84 183**	FKM						
30	Adjustment block	4*	210 341	ST STEEL	4*	210 341	ST STEEL	4*	210 341	ST STEEL

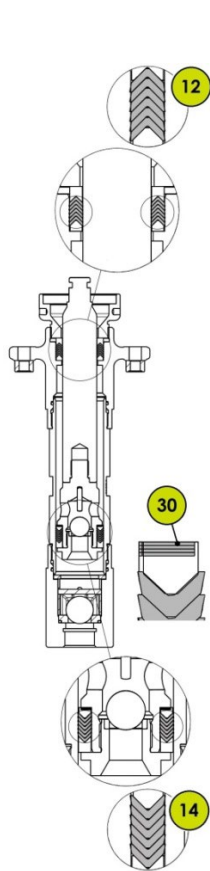

↓			↓			↓		
12			12			12		
PE	→	^	PTFE G	→	^	ACETAL RESIN	→	^
LEATHER	→	^	PTFE G	→	^	PU	→	^
PE	→	^	PTFE G	→	^	PU	→	^
LEATHER	→	^	PTFE G	→	^	PU	→	^
PE	→	^	PTFE G	→	^	PU	→	^
			PTFE G	→	^			
14			14			14		
PE	→	v	PTFE G	→	v	PTFE G	→	v
LEATHER	→	v	PTFE G	→	v	PTFE G	→	v
PE	→	v	PTFE G	→	v	PTFE G	→	v
LEATHER	→	v	PTFE G	→	v	PTFE G	→	v
PE	→	v	PTFE G	→	v	PTFE G	→	v
LEATHER	→	v	PTFE G	→	v	PTFE G	→	v

* Quantity to be assembled as required** According to pump

PTFE G = Graphited PTFE

Seals pack composition: 07

Seals pack :		07		
# :		107 366		
Ind.	Description	Qty	#	Material
9	O-Ring	2	84 394	FKM / FEP
12	Cup packing	3	209 658	PTFE G
		3	209 656	PE
14	Piston packing	3	209 658	PTFE G
		3	209 656	PE
22	O-Ring	1	84 390	PTFE
29	O-Ring	1	909 130 540**	FKM
		1	Or 84 394**	FKM / FEP
30	Adjustment block	4*	210 341	ST STEEL

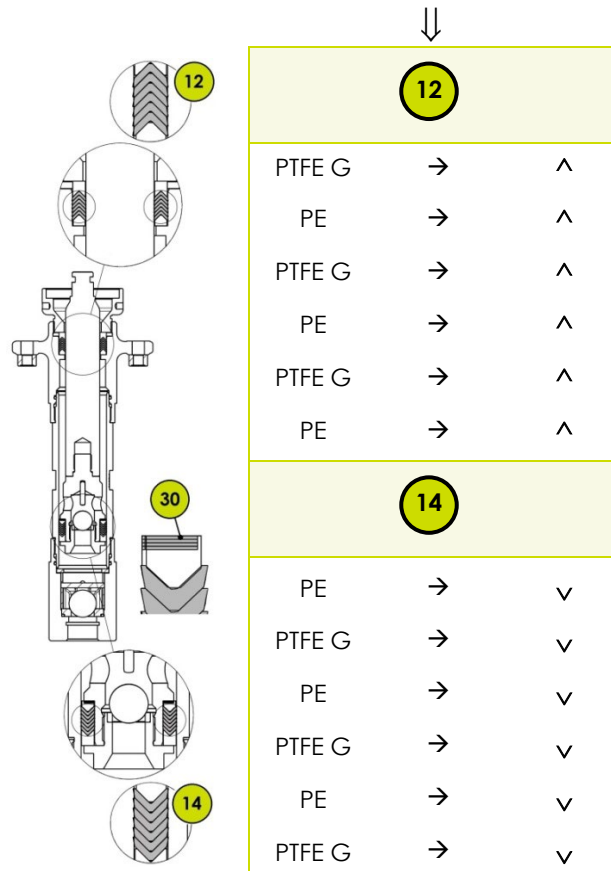

* Quantity to be assembled as required** According to pump

PTFE G = Graphited PTFE