

PNEUMATIC MOTOR MODEL, 3000

Equipment reference

146 310 000

User Manual 582140110

2021-07-22

Ind C

Translation of the original instructions

SAMES KREMLIN SAS

 13 Chemin de Malacher
38240 Meylan

 www.sames-kremlin.com

 33 (0)4 76 41 60 60

Any communication or reproduction of this document, in any form whatsoever, and any exploitation or communication of its contents are prohibited, except with the express written consent of

SAMES KREMLIN.

The descriptions and features contained in this document are subject to change without notice.

© **SAMES KREMLIN** 2021

Contents

1	Declaration of Conformity	6
2	Safety instructions	7
2.1	Personal safety.....	7
2.2	Integrity of the material.....	12
3	Environment	17
4	Presentation of the material	19
4.1	Description of the main elements of the system	20
5	Identification	22
5.1	Description of the marking of the plate.....	22
6	Equipment plans	24
7	Technical characteristics and performance	25
1.1	Technical characteristics	25
8	Handling	26
8.1	Storage	29
8.2	Handling.....	29
9	Commissioning	30
10	Use of the product	31
10.1	User settings.....	31
10.2	Diagnostic help / Troubleshooting guide.....	32
10.3	Possible symptoms of faults / Causes of faults / Remedy to be applied - quick operation	34
11	Maintenance	35
11.1	Preventive Maintenance Plan	35
12	Disassembly / Reassembly Operation	37
12.1	Disassembling the 3000 motor.....	37
13	Pneumatic cabling	41
14	Spare parts	44
14.1	Motor, model 3000	44

- **Evolution table of the document**

Recording revisions				
Editor	Object	Revision	Date	Modified by
SEGUIN	Pneumatic motor Model 3000	A -	Week13/2020	
SEGUIN	Pneumatic motor Model 3000	B -	Week48/2020	
SEGUIN	Pneumatic motor Model 3000	C -	Week29/2021	

Dear customer, you have just purchased your new equipment and we thank you for it.

We have taken the utmost care, from design to manufacture, so that this equipment gives you complete satisfaction.

For a good use and an optimal availability, we invite you to read this manual carefully before using your equipment.

- **Guarantee**

We reserve the right to make any changes or improvements even after receipt of an order without being able to attribute a non-compliance to the descriptions contained in the instruction manuals and selection guides.

Our equipment is checked and tested in our workshops before shipment.

To be valid, any complaint concerning a material will have to be formulated to us in writing within 10 days of the delivery.

SAMES KREMLIN equipment, equipped with its original identification plates, has a one-year warranty or 1800H of operation (first term reached) from the date of ex-factory against any defect of material or defect of it is up to us to see and appreciate.

The warranty excludes wear parts, deterioration or wear resulting from abnormal or unscheduled use by **SAMES KREMLIN**, failure to observe instructions for proper operation or lack of maintenance.

The warranty is limited to the repair or exchange of parts returned to our factory and recognized as defective by us and does not cover the listed wear parts or not.

Any costs resulting from an operating outage can not be charged to us. The costs of return to our workshops are the responsibility of the customer.

An intervention can be carried out on site at the customer's request.

In this case, the transportation and accommodation costs of the technician (s) will remain the responsibility of the applicant.

Any changes made to our equipment without our consent will void the warranty.

Our guarantee is limited to that of the suppliers of materials which enter in the composition of our sets.

1 Declaration of Conformity



Refer to the existing declaration delivered with the product.

2 Safety instructions

2.1 Personal safety

Overview



Read all operating instructions and device labels carefully before putting the equipment into service.

Personnel using this equipment must have been trained in its use.

The workshop manager must ensure that the operators have fully understood all the instructions and safety rules of this equipment and other elements and accessories of the installation.

Misuse or operation can cause serious injury. This material is for professional use only. It must be used only for the purpose for which it was intended.

Do not modify or transform the material. Parts and accessories must only be supplied or approved by **SAMES KREMLIN**.

The equipment must be checked periodically. Defective or worn parts must be replaced.

Never exceed the maximum working pressures of the equipment components.

Always respect the laws in force regarding security, fire, electricity of the destination country of the equipment.

Only use products or solvents that are compatible with the parts in contact with the product (see product manufacturer's technical data sheet).

Meaning of the pictograms

			
Danger pinching, crushin	Danger moving parts	Danger : high pressure	Risks of product emanation
			
Danger : hot parts or surfaces	Danger : flammability risks	Danger : electricity	Risk of explosion
			
Danger (user)	Warning Danger	Gloves required	Grounding
			
Protective helmet	Hearing protection	Mandatory respiratory protection	Safety shoe
			
Protective clothing	Protective visor	Safety glasses is mandatory	Refer to the manual/instruction leaflet

Security devices



Attention

- ✓ Guards (motor cover, coupling guard, housings, ...) are set up for safe use of the equipment.
- ✓ The manufacturer can not be held responsible for any bodily injury as well as failures and / or damage to the equipment resulting from the destruction, the occultation or the total or partial removal of the protectors.
- ✓ Never exceed the maximum working pressures of the equipment components.

Danger of Pressure



Safety requires that a decompressed air shutoff valve be mounted on the pump motor supply circuit to allow trapped air to escape when the supply is shut off.

Without this precaution, the residual air from the engine may cause the motor pump to operate and cause a serious accident.

Similarly, a **product purge valve** must be installed on the product circuit so that it can be purged (after shutting off engine air and decompressing it) before any intervention on the equipment. These valves should remain closed for air and open for the product during the procedure.

Injection hazards



"HIGH PRESSURE" technology requires the utmost care.

Operation can cause dangerous leaks. There is a risk of product injection into exposed parts of the body, which can lead to serious injury and the risk of amputation:

- ✓ An injection of product into the skin or other parts of the body (eyes, fingers ...) must be treated urgently by appropriate medical care.
- ✓ Do not look at the gun nozzle when it is under pressure.
- ✓ Never direct the jet to another person.
- ✓ Never attempt to stop the jet with the body (hands, fingers ...) or with rags or similar.

Fire hazards, explosion, electric arc, static electricity



Improper grounding, insufficient ventilation, open flames or sparks can cause an explosion or fire which could result in serious injury.

To avoid these risks, especially when using pumps, it is imperative:

- ✓ To connect the equipment, the parts to be treated, the cans of products and cleaners to the ground,
- ✓ To ensure good ventilation,
- ✓ Keep the work area clean and free of rags, papers, solvents,
- ✓ Do not operate electrical switches in the presence of vapors or during removal,
- ✓ Immediately stop the application in the presence of arcs,
- ✓ Store all liquids outside the work areas.
- ✓ Use products whose flash point is as high as possible to avoid any risk of formation of flammable gases and vapors (consult the product safety data sheets).
- ✓ To equip the drums with a lid to reduce the diffusion of gases and vapors in the cabin.
- ✓ It is forbidden to pump explosive materials

Hazards of toxic products



Toxic products or vapors can cause serious injury through contact with the body, in the eyes, under the skin, but also by ingestion or inhalation. It is imperative :

- ✓ To know the type of product used and the dangers it represents,
- ✓ Store the products to be used in appropriate areas,
- ✓ Contain the product used in the application in a container designed for that purpose,
- ✓ Evacuate the products in accordance with the legislation of the country where the equipment is used,
- ✓ To wear protective clothing designed for that purpose,
- ✓ Wearing goggles, hearing protectors, gloves, shoes, coveralls and masks for the respiratory tract.



Attention

The use of halogenated hydrocarbon solvents and products containing these solvents in the presence of aluminum or zinc is prohibited.

Failure to follow these instructions exposes the user to the risk of explosion resulting in serious injury or death.

2.2 Integrity of the material

Material recommendations



Protectors are put in place for safe use of the equipment.

Exemples :

- ✓ Engine hood.
- ✓ Carters.

The manufacturer can not be held responsible in case of:

- ✓ Bodily injury.
 - ✓ As well as breakdowns and / or damage to the equipment resulting from the destruction, the occultation or the total or partial withdrawal of the protectors.
-

Pump

Recommendations for pumps.



- ✓ It is essential to read the compatibilities of the motors and pumps before coupling as well as the special safety instructions.
- ✓ These instructions are on the pump instruction manuals.
- ✓ The pneumatic motor is intended to be coupled to a pump. Never modify the coupling system.
- ✓ Keep hands clear of moving parts.
- ✓ The parts constituting this movement must be kept clean.
- ✓ Before starting up or using the motor pump, carefully read the DECOMPRESSION PROCEDURE.
- ✓ Check that the decompression and purge air valves are working properly.
- ✓ It is forbidden to operate the pump without its protective motor cover – risk of crushing
- ✓ It is forbidden to disassemble the safety valve during the operation of the pump – check that the air regulator and pressure gauge are working once a month.

- ✓ Only use genuine **SAMES KREMLIN** accessories and spare parts designed to withstand the pump's operating pressures.

Booster phase of the pump

- ✓ Mandatory wearing of PPE (glasses + gloves + safety shoes).

Feeding cycle

- ✓ The booster cycle must be at a maximum of 1 bar at the gauge of the air equipment, keeping the gun open. Progressive manual mounting to the air regulator.
-

Paint phase pump and pressure gun



- ✓ Mandatory wearing of PPE during this phase of painting where the pump and the gun are under pressure.
- ✓ Do not look at the gun nozzle when it is under pressure.
- ✓ Rinse at a maximum of 1 bar at the pressure gauge of the air equipment (variable pressure depending on the length of the pipes).

Rinsing the pump



- ✓ Wearing PPE (glasses + gloves + safety shoes)
- ✓ Do not look at the gun nozzle when it is under pressure
- ✓ Rinse at a maximum of 1 bar at the pressure gauge of the air equipment (variable pressure depending on the length of the pipes).

Defusing the pump



- ✓ PPE port mandatory.

Risk of fluid section heating during defusing



- ✓ Risk of overheating of the fluid section in case of defusing.

Mass cable



- ✓ It is mandatory to connect the pump to earth. The canes are conductive

Trolley

Concerning the work and displacement of the pump on trolley on a flat floor it is forbidden to pull on the trolley and pump assembly via the pipe.

Hoses

Recommendations for hoses.

- ✓ Keep hoses away from traffic areas, moving parts and hot areas.
- ✓ Never subject product hoses to temperatures above 60 °C or below 0 °C.
- ✓ Do not use hoses to pull or move equipment.
- ✓ Tighten all connections and hoses and connectors before commissioning the equipment.
- ✓ Check hoses regularly, replace them if damaged.
- ✓ Never exceed the maximum operating pressure stated on the hose (PMS).
- ✓ For fitting the hoses and gun: PPE is mandatory.
- ✓ Tighten to block stop. (Pipes + Pistol)

Normal stop

To make a normal stop:

- ✓ Use the air regulator to gradually decompress the pump.

Emergency shut-off valve

- ✓ The stop valve 91458 is an emergency stop valve.
 - ✓ This valve must be within easy reach of the operator.
-

Products implemented

Given the diversity of the products implemented by the users and the impossibility of listing all the characteristics of the chemical substances, their interactions and their evolution over time **SAMES KREMLIN** can not be held responsible:

- ✓ The poor compatibility of materials in contact.
- ✓ inherent risks to staff and the environment.
- ✓ Wear and tear, maladjustment, malfunction of equipment or machines and the quality of the finished product.



The user will have to identify and prevent the potential dangers inherent to the implemented products such as /

- ✓ Toxic vapors.
- ✓ Fire.
- ✓ Explosions.

It will determine the risks of immediate reactions or due to repeated exposures to the staff.

SAMES KREMLIN declines any responsibility, in case of:

- ✓ Bodily or psychic injuries.
 - ✓ Direct or indirect material damage due to the use of chemical substances.
-

3 Environment

The equipment must be installed on a horizontal, stable and flat ground (eg concrete slab).

Non-mobile equipment must be secured by suitable fixing devices (spit, screws, bolts, etc.) to ensure its stability during use.

To avoid risks due to static electricity, the equipment and its components must be grounded.



- ✓ **For pumping equipment** (pumps, elevators, chassis, etc.), a 2.5 mm section wire is attached to the equipment. Use this wire to connect the equipment to the general "earth". In severe environments (mechanical protection of the ground wire, vibrations, moving equipment, etc.) where damage to the grounding function is likely, the user will have to replace the wire of 2, 5 mm supplied, by a device more adapted to its environment (wire of greater section, braid of mass, fixing by lug with eyelet ...).
- ✓ Have the earth continuity checked by a qualified electrician. If earth continuity is not assured, check terminal, wire and grounding point. Never operate the equipment without solving this problem.
- ✓ The gun must be "grounded" through the air hose or fluid hose. In the case of spraying with a pistol equipped with a bucket, the air hose must be conductive.
- ✓ The materials to be painted must also be "grounded" by means of clamps with cables or, if they are suspended, by means of hooks which must remain permanently clean.

Note: all objects in the work area must also be grounded.

-
- ✓ **Do not store** more flammable products than necessary inside the work area.
 - ✓ These products must be stored in **approved containers** and grounded.
 - ✓ Use only grounded **metal buckets** for the use of rinse solvents.
 - ✓ **Cartons and papers are to be banned.** Indeed, they are very bad conductors, even insulators.

Material marking

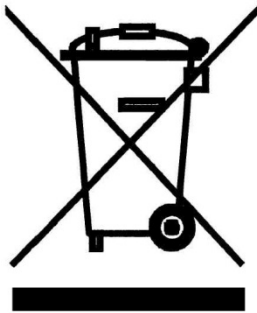

Each device is equipped with a sign plate with the name of the manufacturer, the reference of the device, important information for the use of the device (pressure, power, ...) and sometimes against the pictogram shown below.

The equipment is designed and manufactured with high quality materials and components that can be recycled and reused.

European Directive 2012/19 / EU applies to all devices marked with this logo (crossed out bin). Find out about the collection systems available for electrical and electronic devices.

Comply with the rules in your area and **do not dispose of old appliances with household waste.** Proper disposal of this old device will help prevent adverse effects on the environment and human health.

4 Presentation of the material

Context of use

Kremlin Rexson high viscosity pumps are designed to meet performance and service lifetime requirements :

- ✓ Very high performance pump for maximum energy savings.
- ✓ Optimized design: simple and fast maintenance.

The use of equipment is most often in the workshop or outdoors on site.

4.1 Description of the main elements of the system

Motor 146310000 3000

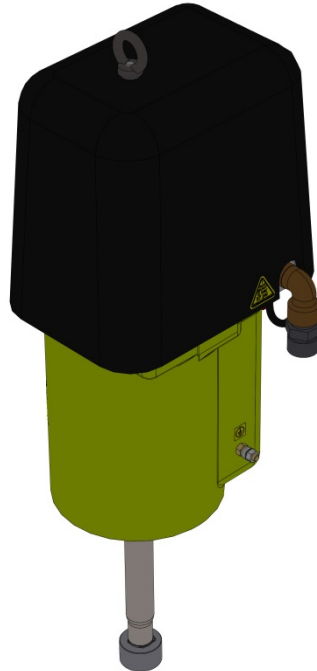

Usage attendu

This pneumatic motor is designed to be coupled to the hydraulics recommended by **SAMES KREMLIN** in order to obtain the required ratio and flow rate.

Functional description

SAMES KREMLIN air motors with straight reciprocating movements operate with compressed air supply. The reversing system is carried out via :

- ✓ A 4/2 bistable distributor.
- ✓ two switches,
- ✓ A 5/2 bistable distributor,

Adjustment

The increase of the motor supply air pressure (via the air regulator) leads to an increase of the number of pump piston returns/mn (cycles) which leads to a flow rate increase and to an outlet pressure increase of the pumped material.

AIR CONSUMPTION OF THE MOTOR	
Pressure of the motor at 6 bar / 87 psi	
Type	daN
3000	920

Pneumatic motor model, 3000

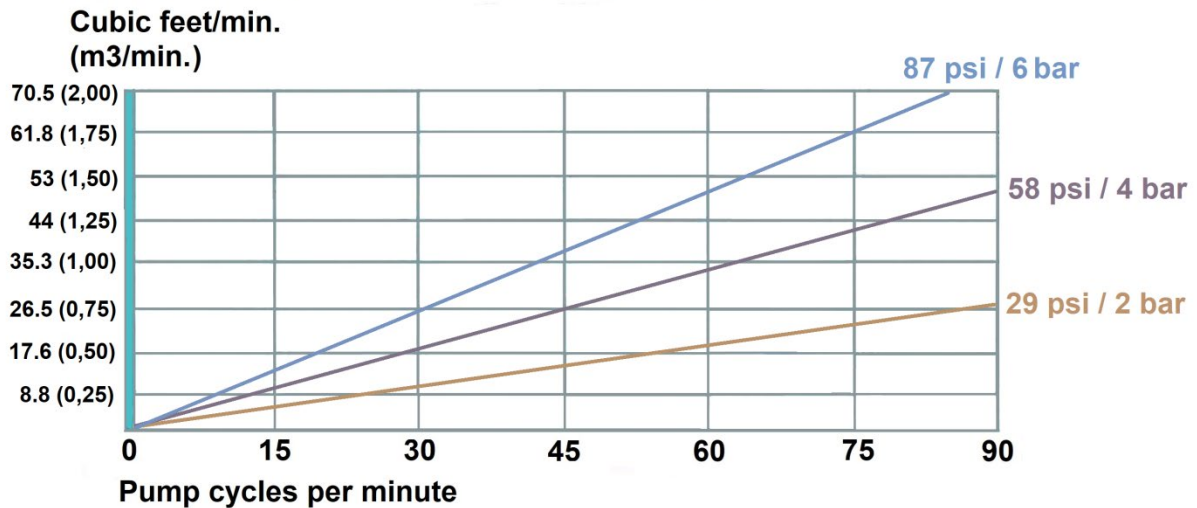

5 Identification

5.1 Description of the marking of the plate



Principles

Paint pumps are designed to be installed in a paint booth.

This equipment complies with the following provisions:

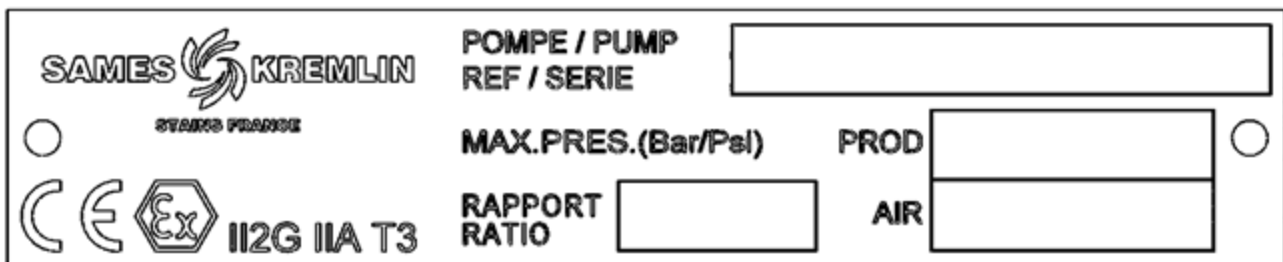
- ✓ ATEX Directive (2014/34 / EU: II 2 G - Group II, Category 2, Gas).



Description	
Sigle SAMES KREMLIN STAINS FRANCE	Manufacturer's mark
POMPE / PUMP REF / SERIE	Pump reference and serial number. The first two digits indicate the year of manufacture.
MAX. PRES. (Bar/Psi)	PROD Maximum product pressure (Bar/Psi)
	AIR Maximum air pressure (Bar/Psi)
RAPPORT / RATIO	Pump pressure ratio
CE	EC: European conformity
	<p> : Use in explosive area</p> <p>II : group II 2 : category 2</p> <p>Surface material intended for an environment in which explosive atmospheres due to gases, vapors, mists are likely to occasionally occur during normal operation.</p> <p>G : gas</p>
IIA T3	<p>IIA : Reference gas for equipment qualification</p> <p>T3 : Maximum surface temperature 200 ° C / 392°F</p>

6 Equipment plans

Motor 3000

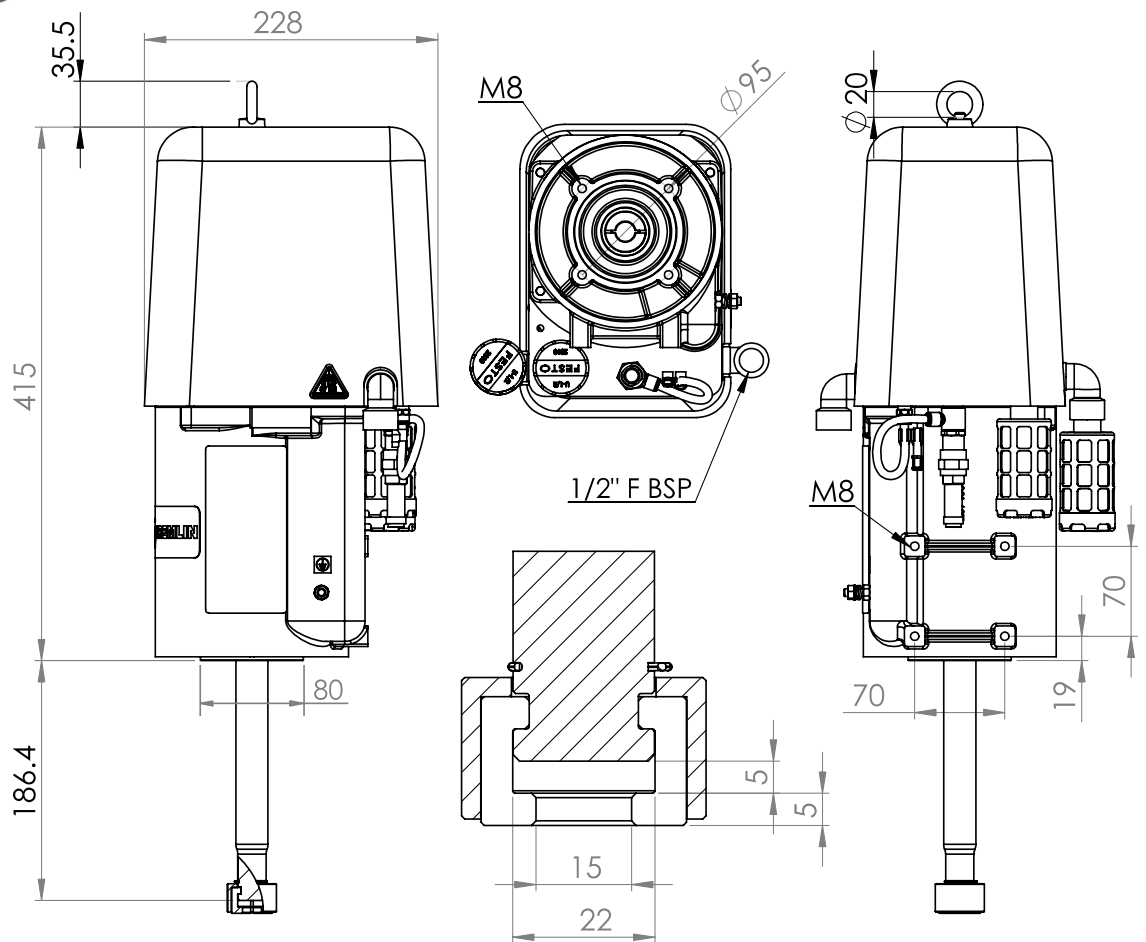

7 Technical characteristics and performance

1.1 Technical characteristics

Motor 3000



Technical characteristics	
Cylinder bore Ø	5.5 in. (140 mm)
Practical stroke	4.7 in. (120 mm)
Maximum stroke	5.2 in. (132 mm)
Air supply Ø	1/2" F BSP
Muffler	1/2" F BSP
Noise level (average)	70 dB
Weight	15.9 lbs (7,2 kg)
Air supply	6 bar
Lower flange thread	M8 on Ø 3.74 in. (sur Ø 95mm)

8 Handling

Connections subsets

Motor – Fluid section

These fluid sections are intended to be coupled to motors (pneumatic or hydraulic) compatible race.

It is imperative to comply with an engine / hydraulic combination provided by **SAMES KREMLIN**

Motor label

 F	MISE EN GARDE	 GB	WARNING	
<ul style="list-style-type: none"> - Les fluides sous haute pression peuvent transpercer la peau et provoquer des blessures graves pouvant nécessiter l'amputation. - Écartez-vous de la buse de pulvérisation ou d'extrusion. - N'arrêtez jamais une fuite avec la main. - EN CAS DE BLESSURE, CONSULTEZ UN MEDECIN IMMÉDIATEMENT. - L'installation dans des zones confinées de matériels de pulvérisation ou d'extrusion de produit, de rinçage ou de nettoyage utilisant des liquides inflammables peut provoquer des incendies ou des explosions. - Les flammes nues, les étincelles et les arcs électriques peuvent enflammer des vapeurs inflammables. - IMPORTANT : ÉLIMINER TOUTE SOURCE DE CHARGE ÉLECTROSTATIQUE. - Reliez à la terre tous les matériels situés dans la zone de travail, y compris les moto-pompes, les flexibles et les pièces à traiter. - Éloignez vous des pièces en mouvement. - Ne dépassez pas les pressions maxi d'utilisation de la moto-pompe ni d'aucun composant de l'installation. 		<ul style="list-style-type: none"> - Liquids under high pressure can pierce the skin, causing serious injury and possible amputation. - Keep clear of gun nozzle or spray tip. - Never stop a leak with your hand. - IN CASE OF INJURY, GET IMMEDIATE SURGICAL TREATMENT. - Spray painting, flushing or cleaning equipment with flammable liquids in confined areas can result in fire or explosion. - Open flames, sparks and electrical arcs can ignite flammable vapors. - IMPORTANT: ELIMINATE ALL IGNITION SOURCES. - Ground all equipment in spray area, including pumps, hoses and objects being sprayed. - Keep clear of moving parts. - Do not exceed pressure rating of pump or any system component. 		REXSON / MOT18
PRESCRIPTIONS DE SÉCURITÉ		SAFETY INSTRUCTIONS		
<ul style="list-style-type: none"> - Lisez le manuel d'instruction et / ou d'exploitation. - Suivre la procédure de décompression avant toute intervention sur la pompe. - Vérifiez les flexibles et les raccords quotidiennement. - Avant l'utilisation, rincez l'appareil avec un produit compatible pour éliminer tout reste éventuel de produits d'essai en usine. 		<ul style="list-style-type: none"> - Read instructions manual / user manual. - Relieve pressure before servicing pump. - Check hoses and fittings daily. - Before using, flush unit with material or solvent to remove any remaining factory test fluid. 		
ÉTIQUETTES SÉCURITÉ DISPONIBLES GRATUITEMENT SUR DEMANDE		SAFETY TAGS FREE OF CHARGE ON REQUEST		

Grounding



Coupled with a pneumatic motor, the fluid section will be grounded via the earth cable of this motor.

This ground cable must be connected to a safe ground

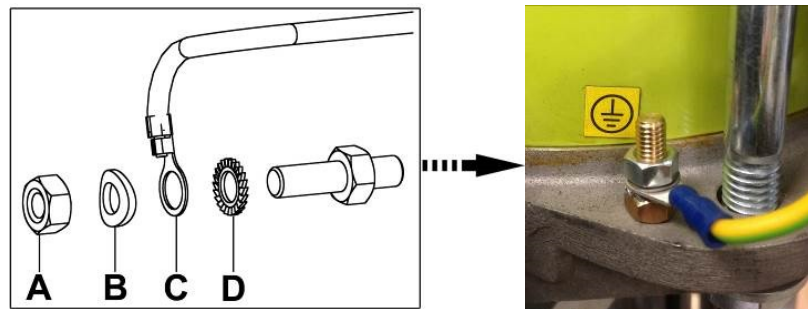

- ✓ Loosen the lock nut (A), remove the washer (B), insert the terminal (C) with its ground wire (min. Section: 1.5 mm²) between the washer (B) and the washer (D).
- ✓ Retighten the lock nut. Connect the other end of the wire to a real "earth" that complies with the regulations of the country concerned.
- ✓ Have the earth continuity checked by a qualified electrician.
- ✓ If earth continuity is not assured, check terminal, wire, bracket, and grounding point.
- ✓ Never operate the pump without having solved this problem.

Connection to compressed air supply

Set the pressure at the air regulator.

For proper operation and long life of the engine, the supply air must be filtered and not lubricated (see § Maintenance).

- ✓ It is imperative to install a decompression valve after the air regulator and as close as possible to the engine inlet in order to follow the decompression procedure (See the pump manual § Operating problems).
- ✓ The engine air supply hose must have an inside diameter of at least 19 mm.
- ✓ The engines are tested before shipping. Nevertheless, before coupling the motor to a pump, it is necessary to operate it under vacuum at a pressure of 1 bar / 14.5 psi maximum for a few minutes.

Proceed as follows:

- ✓ Couple the motor with the recommended pump.
 - ✓ Connect the main air supply to the motor.
 - ✓ Adjust the pressure at the air regulator.
-

8.1 Storage

Pump

Place the equipment away from moisture after closing the various air inlets and various openings (plugs).

Storage before installation:

- ✓ Storage ambient temperature: 0 / +50 ° C.
- ✓ Protect the unit against dust, water runoff, moisture and shocks.

Storage after installation:

- ✓ Protect the unit against dust, water runoff, moisture and shocks.
-

8.2 Handling

Motor

The ring on the top of the cover is intended for lifting the motor and its pump and must not be used for handling a complete machine under any circumstances.

Never submerge the motor.

9 Commissioning

Motor

The engines are being tested before they're shipped.

Nevertheless:

- ✓ Before coupling the motor to a pump, it is necessary to run it under vacuum at a pressure of 1 Bar maximum for a few minutes.
 - ✓ Couple the motor with the recommended pump.
-

10 Use of the product

10.1 User settings



Guards (motor cover, coupling guard, housings, ...) are set up for safe use of the equipment.

The manufacturer can not be held responsible in case of bodily injury as well as breakdowns and / or damage of the material resulting from the destruction, the occultation or the total or partial removal of the protectors.

10.2 Diagnostic help / Troubleshooting guide

Troubleshooting

Before any intervention on a pump, it is imperative to carry out a general procedure of decompression and purge.

In order to avoid the risk of personal injury, product injections, injuries caused by moving parts or arcing, it is essential to follow the following procedure before any intervention during system shutdown, assembly, cleaning or changing the nozzle.

- ✓ Lock the guns (valve, tap, etc.) to OFF.
- ✓ Shut off the air supply via the pressure relief valve to remove residual air from the engine.
- ✓ Unlock the gun (valve, tap ...).
- ✓ Bring the gun (valve, tap ...) to a metal bucket to collect the product. Hold it against the wall of this bucket to avoid interrupting the continuity of the earthing (use the wire with stirrup to put the metal bucket to earth).
- ✓ Open the gun (valve, tap) to bleed the circuit.
- ✓ Lock the gun (valve, tap) to OFF.
- ✓ Open the pump bleed valve and collect the product in a well-grounded metal bucket.
- ✓ Leave this purge valve open during the whole period of the operation.

Check the conformity of the wiring before intervention.

Ice formation

When the compressed air is exhausted, the sudden drop in pressure causes the air temperature to drop below 0°C / 32°F. Any liquid or water vapour then turns to ice.

Higher air pressures pack high amounts of air and water vapor in each cycle and create more expansion and ice. Higher cycle rates also build up the ice and lower the motor temperature faster.

Warm humid climates can produce high levels of icing because of the higher humidity levels. Low ambient temperatures near 0°C / 32°F make it easier for the motor parts to drop below freezing.

To minimize ice build-up:

Lower the dew point of the compressed air. Use a refrigerated air dryer, coalescing filter, or desiccant filter to lower the water vapor content of the air.

Raise the compressed air temperature. Warmer air going in helps the motor parts stay above 0°C / 32°F. Compressed air, especially at these volumes, is warm when compressed. Keep the air warm or stay close to the compressor to reduce ice formation.

10.3 Possible symptoms of faults / Causes of faults / Remedy to be applied - quick operation

Remedies motor part

Perform a decompression procedure before any intervention:

- ✓ shut off the air supply with the pressure relief valve in order to evacuate residual air from the engine,
- ✓ decompress the circuit produced by opening the purge valve of the pump or the gun.

Description	Causes	Remedies
Motor piston lock	Defective switch	Adjust or replace the switch(es)
	Defective control distributor	Check operation, replace if necessary
	Defective power distributor	Check operation, replace if necessary
Decrease of product flow	Escape leak	Check the piston seals, change them if necessary
		Check the distributor seals, change them if necessary
	Silencer clogged	Clean or change the muffler
Large exhaust leak	Improper installation of the distributor base gasket	Reassemble the seal in the correct direction
	Defective power distributor	Check operation, replace if necessary.

11 Maintenance

11.1 Preventive Maintenance Plan

**Attention**

Before any intervention, it is imperative to follow the decompression procedure and the safety instructions.

During prolonged shutdown, stop the pump when the piston is in the low position.

**Attention**

The motor is subject to the ATEX directive and must not be modified under any circumstances.

Failure to comply with this recommendation does not engage our responsibility.

The motor is designed to keep maintenance to a minimum (filtered supply air).

It is advisable to provide preventive maintenance after 12 months of operation.

Check:

- ✓ The clogging of the air filter.
 - ✓ The absence of air leaks.
 - ✓ The absence of breaks in the air hoses.
 - ✓ The correct snapping of the connections / hoses.
 - ✓ The general condition of the supply hoses (rubber, crimping), regulators and manometers.
 - ✓ The tightening of the components.
 - ✓ The condition of the muffler (s).
 - ✓ The fixing of the hood.
 - ✓ The correct operation of the safety valve.
 - ✓ The state of the decompression valve.
-

Greases and glu

Instruction	Designation	Reference
High performance grease	Box of fat Kluber petamo HY 133N (1 kg /2.2 lbs)	560.440.005
Anaerobic Glue PTFE Waterproof Tube	Loctite 5772 (50 ml / 1.7 oz)	554.180.015
Anaerobic adhesive low thread	Loctite 222 (50 ml / 1.7 oz)	554.180.010

This maintenance consists of replacing parts with cuts or wear and cleaning organs with compatible products without using abrasive materials that could damage them.

The O-rings are mounted with special "pneumatic" grease.

Make sure that none of them get damaged; cutting one of them may cause the engine to malfunction.

12 Disassembly / Reassembly Operation



Attention

Before any intervention, it is imperative to follow the decompression procedure and the safety instructions.

12.1 Disassembling the 3000 motor

The maintenance consists in changing the damaged parts and cleaning the parts with compatible materials without using abrasive materials which can damage them. The O-Rings are mounted with a 'special pneumatic' grease. Make sure during the assembly that the seals are not damaged to avoid a bad operating of the motor.

Disassembly of the grounding cable

- ✓ Hold the grounding terminal with a 10 mm spanner and unscrew the upper nut with the other key.
- ✓ Manually remove the washers and the grounding cable.

Tools needed

10 x2



Disassembly of the motor and of the fluid section

- ✓ Adjust the air regulator to 0 psi (0 bar),
- ✓ Shut off the air supply from the motor, then carry out the pressure release and drain instructions,
- ✓ Take off the axis lock (33),
- ✓ Lift the closing ring (34),
- ✓ Take off the two half bushes (35) and put aside the closing ring,
- ✓ Remove the fixing screws of the motor,
- ✓ Put aside the motor.

Disassembly of the distributors and of the sensors

- ✓ Unscrew the hoisting ring (1) and remove the washer (2),
 - ✓ Take off the cover (3) and disconnect the air hoses,
 - ✓ Unscrew the 4 screws (4), put aside the distributor (7) and remove the base seal,
 - ✓ Unscrew the 2 screws (30) and put aside the distributor (28),
 - ✓ Unscrew the 2 screws (18) and remove the U-bolt (17),
 - ✓ Unscrew the 4 screws (51) and put aside the sensors (29),
 - ✓ Unscrew the 2 screws (52) and put aside the sensors/distributor support (37),
 - ✓ Change the defective parts.
-

Reassembly

The assembly is carried out in the reverse order of the disassembly sequence. Caution to the following instructions :

- ✓ During the changing of the sensors (29), push them in the opposite direction of the piston rod, then tighten the screws,
- ✓ The wheels must flush up the reversing rod,
- ✓ Cable once again the parts according to the pneumatic diagram,
- ✓ Orientate the distributor base seal (7) according to the A and B indexes.

Changing the seals of the upper and lower flanges of the piston

- ✓ Unscrew the ring (1) and remove the washer (2),
- ✓ Remove the cover (3),
- ✓ Unscrew the screw (52), put aside the cam (19),
- ✓ Unscrew the 4 screws (20), take off the cover assembly (8),
- ✓ Take off the reversing rod assembly (25) / piston (24) / piston rod (32),
- ✓ Take off the piston seal (11) and the bearing seals (15, 21 & 22),
- ✓ Clean the parts, change them if necessary.

Reassembly

The assembly is carried out in the reverse order of the disassembly sequence. Caution to the following instructions :

- ✓ Stage 6 : Assembly of the piston floating seal (11) : first, insert the seal (with a light coating of special pneumatic grease) in the groove of the piston. Position the rod/piston/seal assembly above the cylinder. Press on the sides of the seal until the piston/rod assembly slides inside the cylinder.
 - ✓ the nut (23) and the piston rod (32) are installed with a light coating of glue (Eg . Loctite 222).
 - ✓ the piston rod (32) and the piston (24) are installed with glue (Eg. Loctite 5772),
 - ✓ the seal (12) must be correctly mounted before mounting the cover (8).
-

13 Pneumatic cabling

SERIES 3000

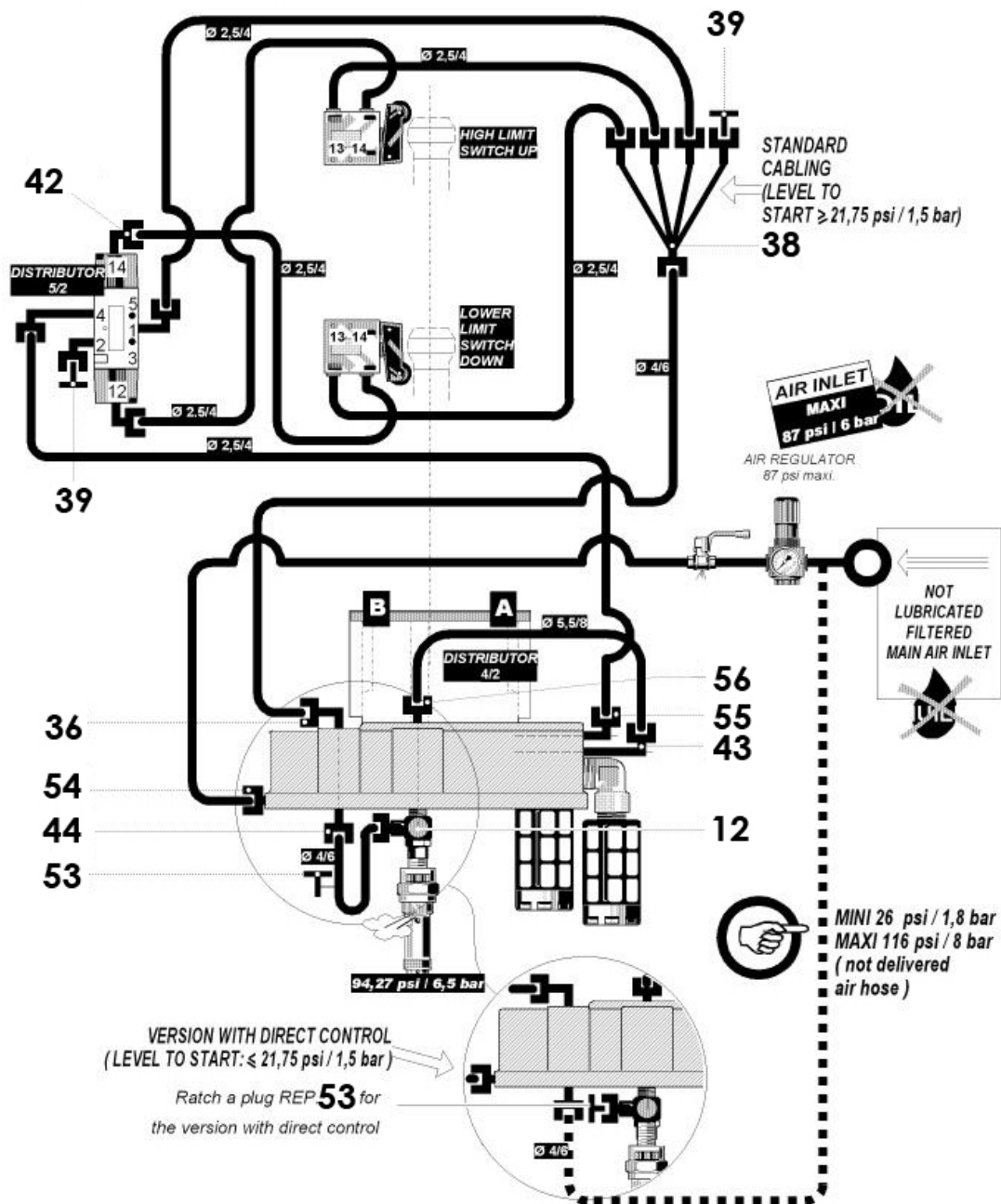

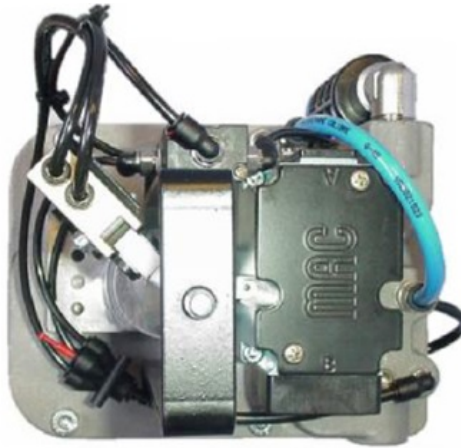
Model 3000

Pulse pick-up

The pulse pick-up provides a pneumatic signal that indicates the direction of motor operation. When the impulse port is at a pressure equal to the pilot pressure, this means that the motor piston is in an upward phase. When the pulse pick-up is at atmospheric pressure, the motor is then in a descending phase. This pulse pick-up is generally used to count the number of engine reversals and allows the addition of a runaway prevention system.

Standard cabling

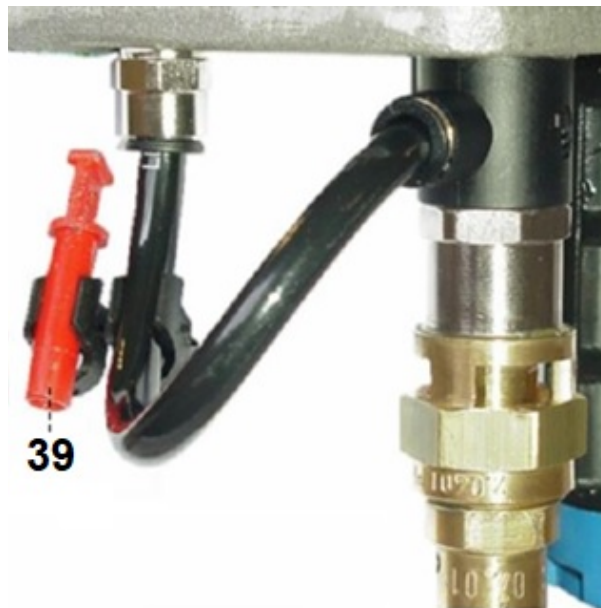

All factory assembled motors are wired in **standard control**. This means that the pneumatic motor reversing system (called pilot) is connected to the same pressure as the main motor supply. In this case, the starting threshold of the motor is approximately 21.7 psi. (1,5 bar).

Direct piloting

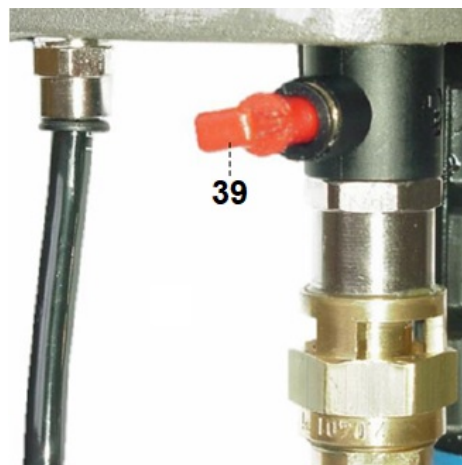

Direct piloting allows the user to connect the pneumatic motor reversing system (called pilot) to an independent pressure source. This allows the user to start the motor at a supply pressure of approximately 7.25 psi (0.5 bar) or to use the pilot pressure to control the starting and stopping of the motor.

14 Spare parts

Use only genuine **SAMES KREMLIN** accessories and spare parts designed to withstand the pump's operating pressures.

14.1 Motor, model 3000

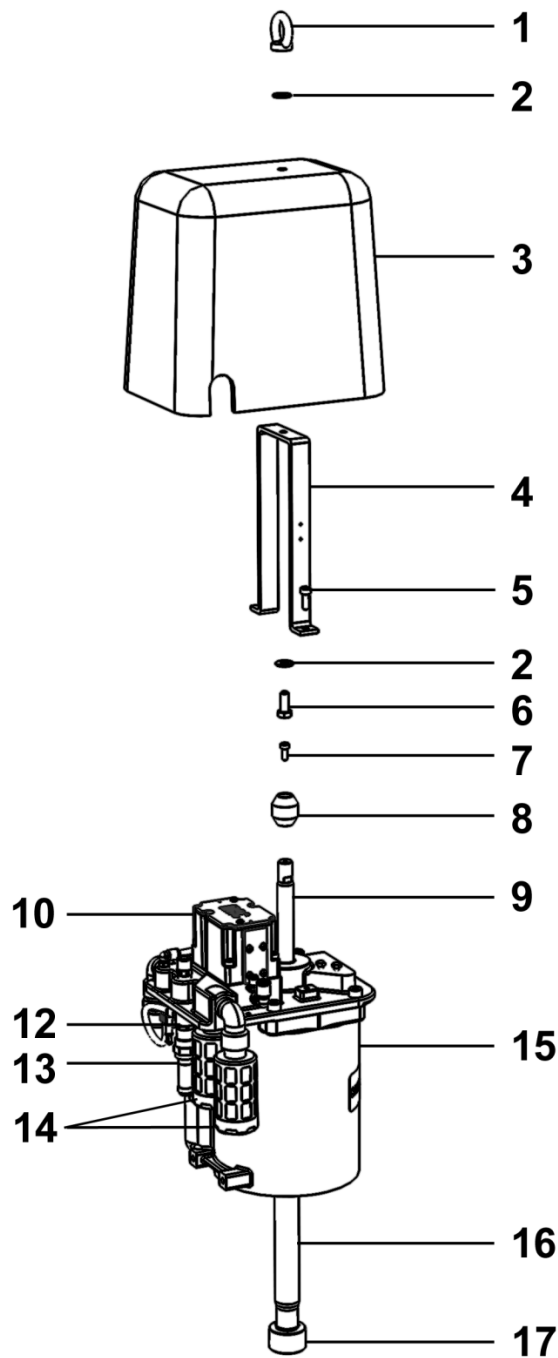

Ind	#References	Description	Qty	Spare part level**
1	91 421	Hoisting ring	1	0
2	963 040 019	Washer	2	0
3	210 311	Cover	1	0
4	210 286	U-Bolt	1	0
5	933 151 196	Screw CHc M 6 x 16	2	0

6	933 011 279	Screw HM 8 x 20	1	0
7	88 121	Screw CHc M 5 x 12	1	0
8	210 444	Cam	1	3
9	210 443	Reversing rod	1	0
10	146 310 092	Distributor, model 4/2	1	3
11	N.S. (209 404)	Base seal	1	2
12	552 542	Air fitting 1/4" G - 1/2" JIC	1	0
*13	903 080 401	Safety valve 6.5 bar	1	2
*14	146 310 091	Muffler (x2)	2	2
15	209 405	Cylinder	1	2
-	210 284	Sleeve	1	2
16	210 441	Piston rod	1	0
17	205 094	Closing ring	1	0

* Recommended maintenance parts.

N S: Denotes parts are not serviceable.

**Level 0 : Parts that are not spare parts

Level 1 : Preventive maintenance

Level 2 : Corrective maintenance

Level 3 : Exceptional maintenance

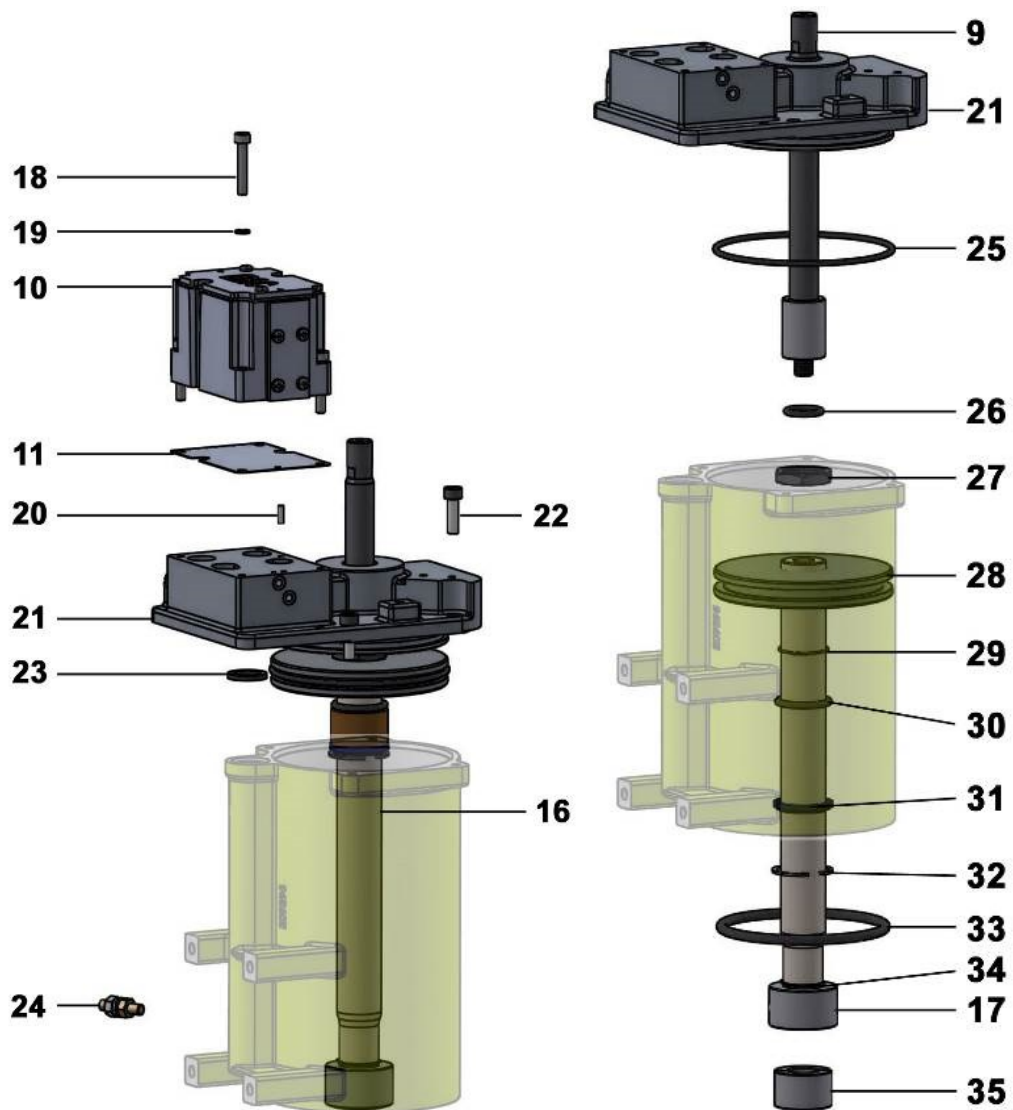

Ind	#References	Description	Qty	Spare part level**
18	N.S. (933 151 385)	Screw CHc M 5 x 30	4	0
19	N.S. (963 210 014)	Washer WZ 5	4	0
20	N.S. (88 425)	Pin	1	0
21	N.S. (210 440)	Cover	1	0
22	88 152	Screw CHc M 6 x 20	4	0
23	N.S. (209 808)	Flat seal	1	1
24	104 790	Grounding terminal	1	0
25	N.S. (84 374)	O-Ring	1	1
26	N.S. (84 452)	Seal	1	1
27	210 442	Nut	1	0
*28	209 407	Piston	1	2
29	N.S. (88 654)	Ring	1	1
30	N.S. (81 019)	NBR seal	1	1
31	N.S. (84 400)	Scraper seal	1	1
32	N.S. (88 899)	Ring	1	1
33	N.S. (84 372)	O-Ring (piston)	1	1
34	90 040	Axis-lock	1	0
35	209 394	Bush (2 parts)	1	0

* Recommended maintenance parts.

N S: Denotes parts are not serviceable.

**Level 0 : Parts that are not spare parts

Level 1 : Preventive maintenance

Level 2 : Corrective maintenance

Level 3 : Exceptional maintenance

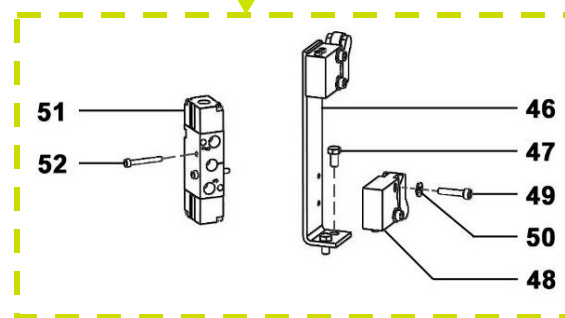
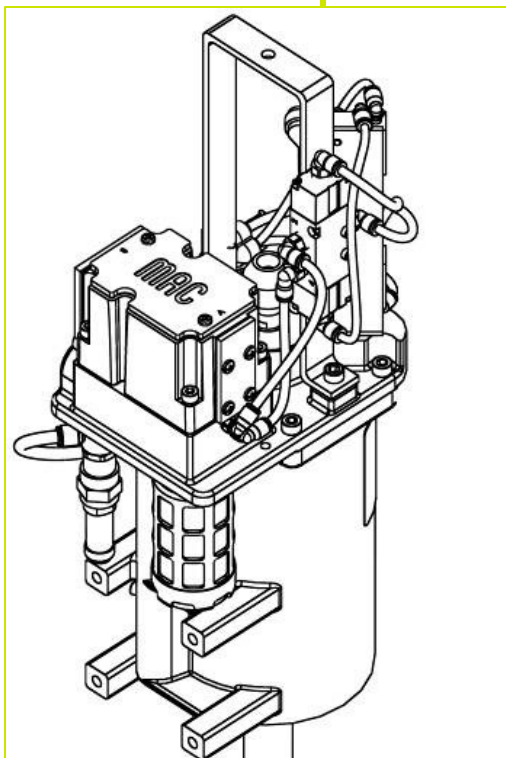
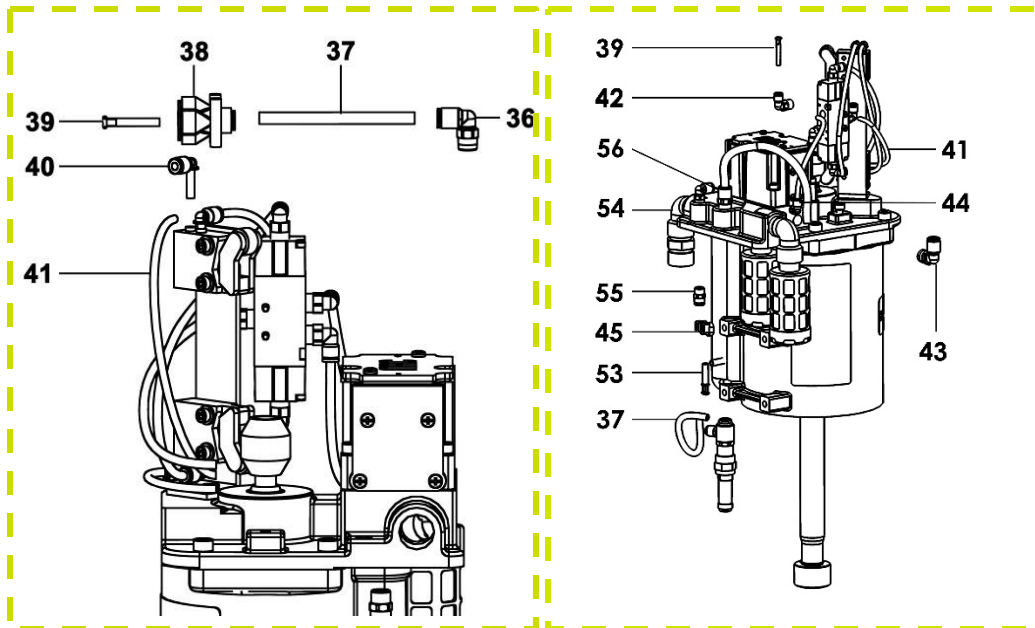

Ind	#References	Description	Qty	Spare part level**
36	905 120 902	Elbow, M 1/8" G Ø6	1	0
37	N.S. (76 607)	Hose PU 4 x 6 (lg. 0.20 m / 7.87")	1	0
38	552 226	Fitting, Y T 4x6	1	0
39	905 120 937	Tube plug Ø6	2	0
40	905 120 983	Elbow, MF T 2x4	4	0
41	N.S. (76 764)	Hose PU 2,5x4	1	0
42	905 120 926	Elbow, model M 1/8" G Ø4	5	0
43	905 120 912	Elbow, model M 1/4" G Ø8	1	0
44	552 260	Elbow, model M 5 G Ø4	1	0
45	91 723	Straight fitting, model 1/8"	2	0
46	210 445	Clip, model Ø 6	1	0
47	933 011 143	Bracket	2	0
*48	151 800 002	Screw, model HM 5x10	1	2
49	933 151 273	Switch (x 2)	4	0
50	963 040 012	Screw, model CHc M 4x20	4	0
51	91 424	Washer, model MU 4	1	2
52	932 151 326	Distributor, model 5/2 1/8"	2	0
53	905 120 924	Tube plug	1	0
54	552 433	Elbow, MF 1/2" G	1	0
55	905 124 901	Fitting G1/8" – Ø6	1	0
56	905 120 904	Fitting G1/4" – Ø8	1	0

* Recommended maintenance parts.

N S: Denotes parts are not serviceable.

**Level 0 : Parts that are not spare parts

Level 1 : Preventive maintenance

Level 2 : Corrective maintenance

Level 3 : Exceptional maintenance

Ind	#References	Description	Qty	Spare part level**
*	146 310 090	Seal kit air motor (ind. 23, 25, 26, 29, 30, 31, 32, 33)	1	1
*	146 320 094	Pneumatic kit (Ind. 48, 51)	1	2

* Recommended maintenance parts.

N S: Denotes parts are not serviceable.

**Level 0 : Parts that are not spare parts

Level 1 : Preventive maintenance

Level 2 : Corrective maintenance

Level 3 : Exceptional maintenance

Accessory



Ind	#References	Description	Qty
-	144 246 295	2 tie rods flange	1