

XCITE®+ & XCITE®+ LIGHT AIRMIX® PREVENTATIVE MAINTENANCE SCHEDULE

PLEASE NOTE: The frequency of maintenance indicated in the procedures below is only indicative. The user will have to create their own range of maintenance as they use the Sames equipment.

Procedure	Detail	Duration	Frequency
Replacement			
Maintenance of the aircap (2) and of the tip (3)			
A	A1	Disassembly of the aircap (2) and of the tip (3)	15s Daily
	A2	Re-assembly of the aircap (2) and of the tip (3)	15s Daily
Maintenance of the seat-holder assembly (4)			
B	B1	Disassembly of the seat-holder assembly (4)	1min 30s Weekly
	B2	Re-assembly of the seat-holder assembly (4)	1min 15s Weekly
Maintenance of the needle assembly (9) and of the air valve (10)			
C	C1	Disassembly of the needle assembly (9) and of the valve (10)	1min 50s Quarterly
	C2	Re-assembly of the needle assembly (9) and of the valve (10)	1min 50s Quarterly
Maintenance of the fan adjustment valve (15)			
D	D1	Disassembly of the fan adjustment valve (15)	15s Quarterly
	D2	Re-assembly of the fan adjustment valve (15)	15s Quarterly
Maintenance of the trigger (5)			
E	E1	Disassembly of the trigger (5)	30s Annually
	E2	Re-assembly of the trigger (5)	30s Annually
Maintenance of the safety lever (5.5)			
F	F1	Disassembly of the safety lever (5.5)	15s Annually
	F2	Re-assembly of the safety lever (5.5)	15 s Annually
Maintenance of the fluid tube assembly (21) (for Xcite®+)			
G	G1	Disassembly of the fluid tube assembly (21)	1min 50s Quarterly
	G2	Re-assembly of the fluid tube assembly (21)	1min 50s Quarterly
Maintenance of the fitting (16) (for Xcite®+ Light)			
H	H1	Disassembly of the fitting (16)	20s Quarterly
	H2	Re-assembly of the fitting (16)	20s Quarterly

(* Data for an average use of 8 hours per day.
ATTENTION: The values are given for use without leakage or poor condition of the parts.
Adapt the frequency of maintenance according to the usage.

REPLACEMENT



ATTENTION: Before any intervention, conduct a pressure relief procedure (see § 5.3.2 page 25 of the user manual) and follow the health & safety instructions (see § 1 page 7)

PROCEDURE A1: DISASSEMBLY OF THE AIRCAP (2) & TIP (3)

- Step 1:** Unscrew the aircap ring (2.2) from the gun body (1).
- Step 2:** Remove the tip (3) from the aircap (2).
- Step 3:** Clean and/or change the parts.

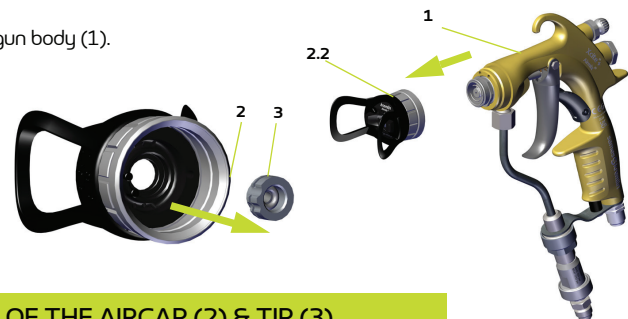

PROCEDURE A2: RE-ASSEMBLY OF THE AIRCAP (2) & TIP (3)

- Step 1:** Install the tip (3) on the aircap (2).
- Step 2:** Tighten the aircap ring (2.2) on the gun body (1).

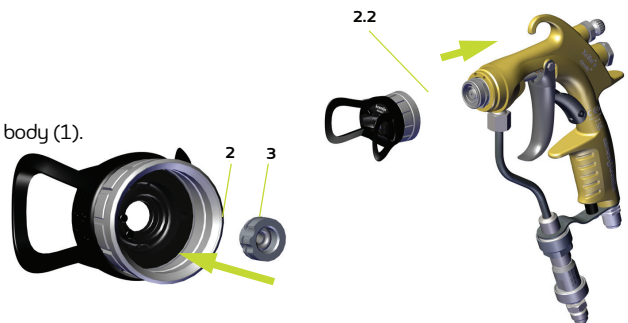

PROCEDURE B1: DISASSEMBLY OF THE SEAT-HOLDER ASSEMBLY (4)

- Step 1:** Remove the aircap (2) from the gun body (1).



ATTENTION: If the springs (9.1 & 10.1) are not removed, go to step 2, otherwise go to step 3.

- Step 2:** Press the trigger (5) to move the needle (9.4) back from the seat (7.2).
- Step 3:** Unscrew the seat-holder (4) by means of the wrench supplied with the gun.
- Step 4:** Release the trigger (5).
- Step 5:** Check the condition of the parts and the seals (4.2, 4.3 and 4.4). Change them if necessary.

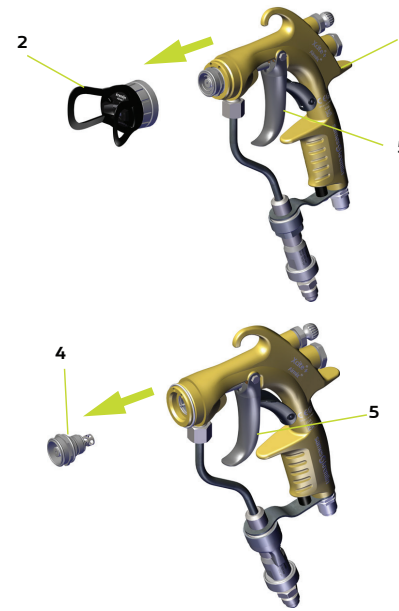

ATTENTION: To change the seal, apply grease (PTFE) on the starter seal tool. Install the seal (4.4) on the starter seal tool. Insert the seal (4.4) on the seat holder (4.1) by means of the seal installation tool. **NOTA:** Starter seal tool and seal installation tool supplied in the kit part number 129 729 922.

- Step 6:** Unscrew the cartridge stop (6).
- Step 7:** Loosen the screw (4.5) with a screwdriver.

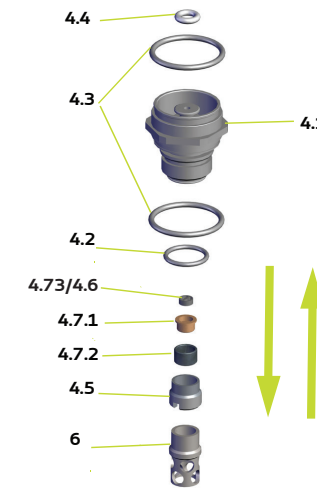

ATTENTION: be careful not to lose the diffusor (4.6) during disassembly. **Step 8** Check the condition of the seat (4.7.2), of the seal (4.7.1) and of the diffusor (4.7.3/4.6).

PROCEDURE B2: RE-ASSEMBLY OF THE SEAT-HOLDER ASSEMBLY (4)



ATTENTION: for re-assembly, present the parts vertically.

- Step 1:** Reinstall the diffusor (4.6), the seal (4.7.1) and the seat (4.7.2)
- Step 2:** Screw in the screw (4.5). Tightening torque: 2Nm/1.47 ft-lb
- Step 3:** Screw in the cartridge stop (6) until it stops

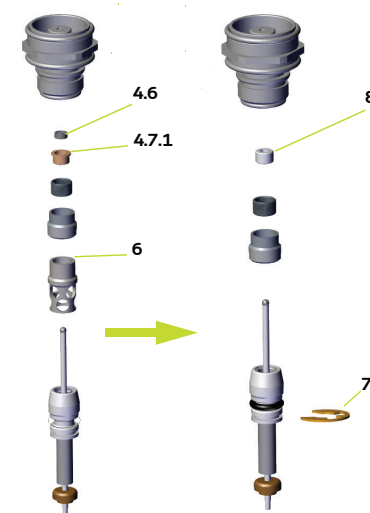

ATTENTION: If the cartridge stop (6) and the diffusor (4.6) are not used, the circlip (7.2) must be used instead of the cartridge stop (6) and the seal (8) instead of the diffusor (4.6) and the seal (4.7.1).

Kit part number: 129.732.080

- Step 4:** Apply grease (PTFE) to the seat-holder (4). threads.



ATTENTION: If the springs (7.1 & 10.1) are not removed, go to step 5, otherwise go to step 6.

- Step 5:** Press the trigger (5) to move the needle (7) back.
- Step 6:** Tighten the seat holder (4) in the gun. Tightening torque: 24 Nm / 17.7 ft-lb.
- Step 7:** Release the trigger (5).
- Step 8:** Screw the aircap (2) on the gun body (1).

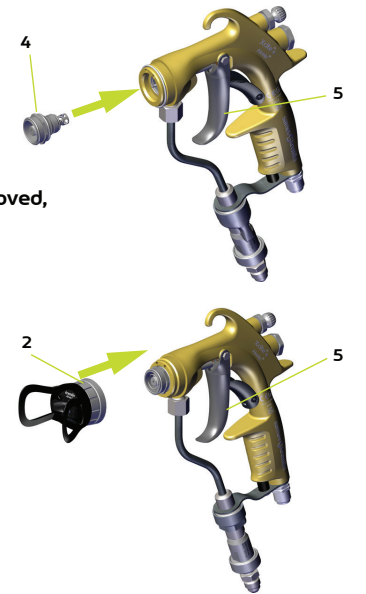

PROCEDURE C1: DISASSEMBLY OF THE NEEDLE ASSEMBLY (7) AND AIR VALVE (10)

- Step 1:** Unscrew the needle stop sleeve (11) by means of the wrench.
- Step 2:** Remove the springs (7.1 & 10.1), the needle carrier (12) and the needle rod (13).
- Step 3:** Press the trigger (5).
- Step 4:** Remove the air valve (10).
- Step 5:** Remove the screw (5.1) with a 5.5 mm wrench. Remove the trigger spindle (5.2).
- Step 6:** Remove the trigger (5.3).
- Step 7:** Remove the seat-holder (4).
- Step 8:** Pull the needle assembly (7) toward the front of the gun with a pin punch.

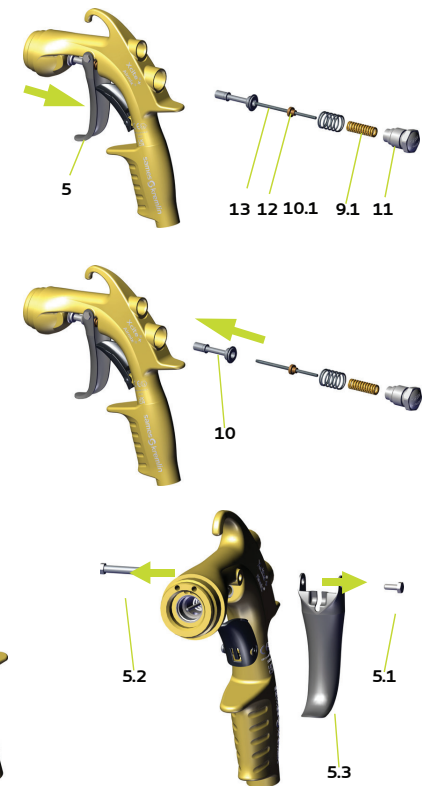

ATTENTION: If necessary, change the seal (7.3) or the complete needle assembly (7).

XCITE®+ & XCITE®+ LIGHT AIRMIX® PREVENTATIVE MAINTENANCE SCHEDULE

PROCEDURE C2: RE-ASSEMBLY OF NEEDLE ASSEMBLY (7) & AIR VALVE (10)

ATTENTION: If necessary, change the seal (14) or the complete needle assembly (9).

- Step 1:** Lubricate (PTFE) the seal (7.3).
- Step 2:** Insert the new needle assembly (7) from the front.
- Step 3:** When mounting the seat-holder (4), the needle assembly (7) must come to a stop.
- Step 4:** Grease (PTFE) springs (7.1 & 10.1), the needle rod (13), the air valve (10) and the needle stop thread (11).
- Step 5:** Install the air valve (10), the needle rod (13), the needle carrier (12) and the springs (7.1 & 10.1).
- Step 6:** Screw the needle stop thread (11). Tightening torque: 10 Nm / 7.37 ft-lb.
- Step 7:** Apply glue (Loctite 222) on the screw thread (5.1). Replace the trigger (5.3) and the trigger spindle (5.2).
- Step 8:** Tighten the screw (5.1).

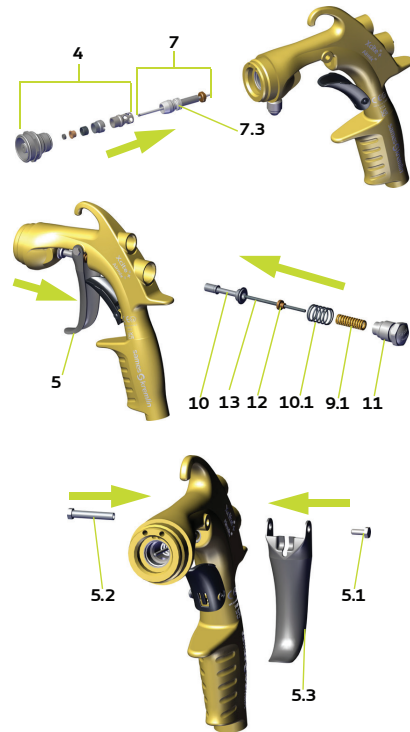

PROCEDURE F1 & F2: DISASSEMBLY & RE-ASSEMBLY OF THE SAFETY LEVER (5.5)

- F1**
 - Step 1:** Remove the pin (5.4) with a pin driver.
 - Step 2:** Remove the safety lever (5.5) from the gun body (1).
- F2**
 - Step 1:** Place the safety lever (5.5) in the gun body (1).
 - Step 2:** Insert the pin (5.4).

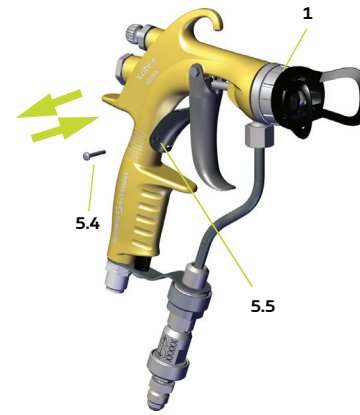

PROCEDURE G1: DISASSEMBLY OF THE PROTECTIVE TUBE ASSEMBLY (21) FOR XCITE®+ GUNS

- Step 1:** Unscrew the nut (20.1) by means of the wrench supplied with the gun.
- Step 2:** Remove the screen support (21.1) and the screen (21.2).
- Step 3:** Remove the seal (21.3).

- Step 4:** Unscrew the fitting (14).
- Step 5:** Loosen the screw (21.4) with a 4 mm hex key.

- Step 6:** Unscrew the fluid tube (21.5).
- Step 7:** Check the condition of the parts as well as the seal (21.3). Change them if necessary.

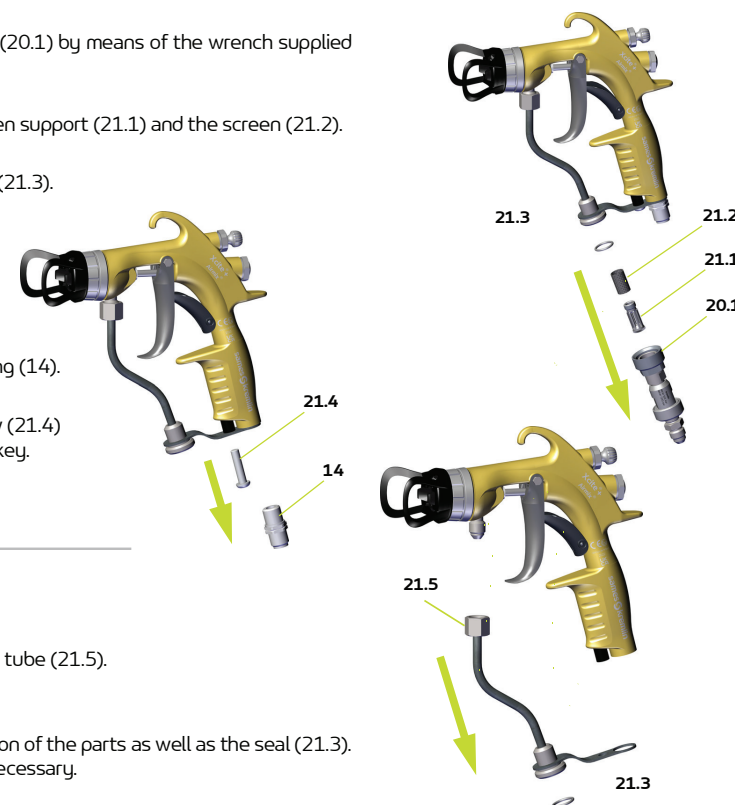

PROCEDURE G2: RE-ASSEMBLY OF THE PROTECTIVE TUBE ASSEMBLY (21) FOR XCITE®+ GUNS

- Step 1:** Screw the fluid tube (21.5).

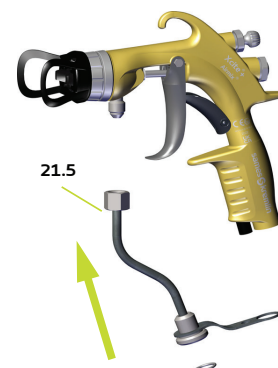

PROCEDURE D1 & D2: DISASSEMBLY & RE-ASSEMBLY OF THE FAN ADJUSTMENT VALVE (15)

ATTENTION: Before each installation or disassembly of the fan adjustment valve (15) in the gun, check that it is in the open position.

- D1**
 - Step 1:** Unscrew the fan adjustment valve (15) with the wrench supplied with the gun.

- D2**
 - Step 1:** Screw the new fan adjustment valve (15) with the wrench supplied with the gun.

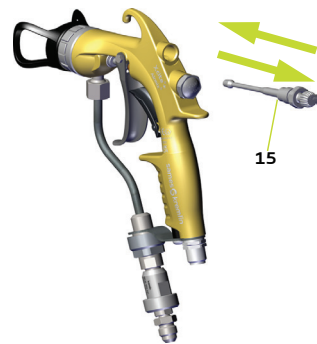

PROCEDURE E1 & E2: DISASSEMBLY & RE-ASSEMBLY OF THE TRIGGER (5)

- E1**
 - Step 1:** Loosen the screw (5.1) with a 5.5 mm wrench.
 - Step 2:** Remove the trigger spindle (5.2).
 - Step 3:** Remove the trigger (5.3).

- E2**
 - Step 1:** Apply glue (Loctite 222) to the screw thread (5.1).
 - Step 2:** Place the trigger (5.3) and the trigger spindle (5.2).
 - Step 3:** Tighten the screw (5.1).

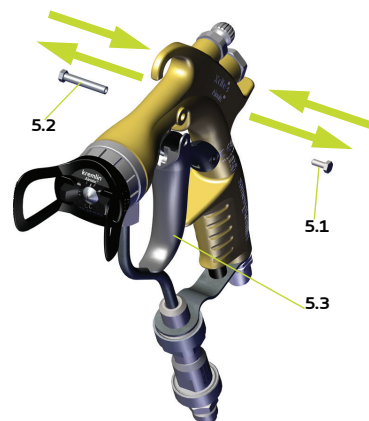

- Step 2:** Apply glue (Loctite 222) to the thread of the screw (21.4). Screw it onto the body (1) of the gun.
- Step 3:** Apply glue (Loctite 222) to the thread of the fitting (14).
- Step 4:** Tighten the fitting (19) in the gun body (1). Tightening torque: 10 Nm / 7.37 ft-lb.

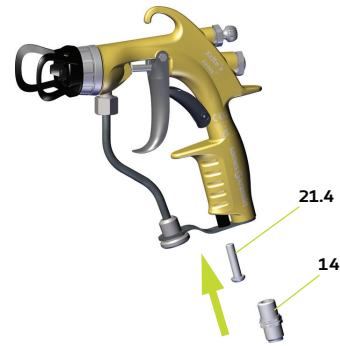

- Step 5:** Insert the screen (21.2) onto the screen support (21.1).
- Step 6:** Place the seal (21.3). Insert the screen support (21.1) into the protective tube (21.5).
- Step 7:** Tighten the nut (20.1) by means of the wrench supplied with the gun.

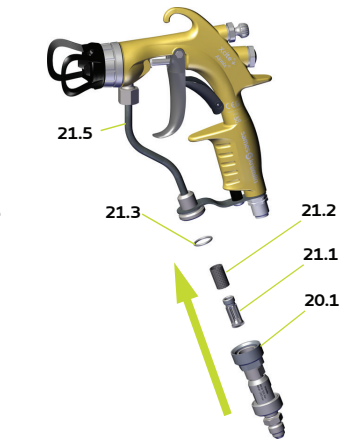

PROCEDURE H1 & H2: DISASSEMBLY & RE-ASSEMBLY OF THE FITTING (16) FOR XCITE®+ LIGHT GUNS

- H1**
 - Step 1:** Unscrew the fitting (16).
 - Step 2:** Remove the seal (17). Check it and change it if necessary.

- H2**
 - Step 1:** Place the seal (17).
 - Step 2:** Screw the fitting (16).

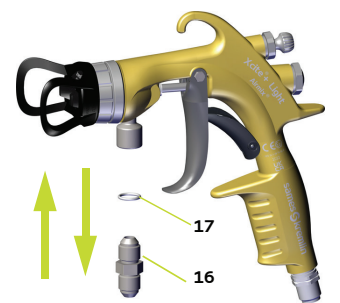

LT 999-600-522 ©2023 Sames North America Corporation reserves the right to change without notice characteristics and services offered as well as equipment and attachments of these.